

# RICOH

SLR Digital Camera

# PENTAX *KP*

## Operating Manual

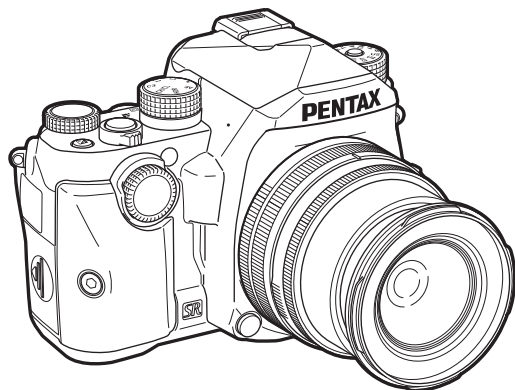

Introduction **1**

Getting Started **2**

Shooting **3**

Playback **4**

Sharing **5**

Settings **6**

Appendix **7**

To ensure the best performance from your camera, please read the Operating Manual before using the camera.

# For Using Your Camera Safely

We have paid close attention to the safety of this camera. When using this camera, we request your special attention regarding items marked with the following symbols.



## Warning

This symbol indicates that ignoring this item could cause serious personal injuries.



## Caution

This symbol indicates that ignoring this item could cause minor or medium personal injuries, or loss of property.

## About the Camera



### Warning

- Do not disassemble or modify the camera. High voltage areas are present inside the camera, with the risk of electric shock.
- If the camera interior is exposed due to dropping or otherwise damaging the camera, never touch the exposed portion. There is a risk of electric shock.
- Do not aim the camera at the sun or other strong light sources when taking pictures or leave the camera sitting in direct sunlight with a lens cap off. Doing so may cause the camera to malfunction or cause a fire.
- Do not look at the sun or other strong light sources through a lens. Doing so may lead to a loss of eyesight or cause vision to be impaired.
- If any irregularities occur during use, such as smoke and a strange odor, stop using the camera immediately, remove the battery or the AC adapter, and contact your nearest service center. Continued use can cause a fire or electric shock.



### Caution

- Do not place your finger over the flash when discharging the flash. You may burn yourself.
- Do not cover the flash with clothing when discharging the flash. Discoloration may occur.
- Some portions of the camera heat up during use. There is a risk of low temperature burns when holding such portions for long periods.
- Should the monitor be damaged, be careful of glass fragments. Also, be careful not to allow the liquid crystal to get on your skin or in your eyes or mouth.
- Depending on your individual factors or physical condition, the use of the camera may cause itching, rashes or blisters. In case of any abnormality, stop using the camera and get medical attention immediately.

## About the Battery Charger and AC Adapter



### Warning

- Always use the battery charger and AC adapter exclusively developed for this camera, with the specified power and voltage. Using a battery charger or AC adapter not exclusive to this camera, or using the exclusive battery charger or AC adapter with an unspecified power or voltage can cause a fire, electric shock, or camera breakdown. The specified voltage is 100 - 240V AC.
- Do not disassemble or modify the product. This can cause a fire or electric shock.
- If the generation of smoke or strange odor from the product or other abnormality occurs, immediately discontinue using and consult your nearest service center. Continued use can cause a fire or electric shock.
- If water should happen to get inside the product, consult your nearest service center. Continued use can cause a fire or electric shock.
- If you see a lightning flash or hear thunder during use of the battery charger or AC adapter, unplug the power plug and discontinue using. Continued use can cause damage to the product, fire or electric shock.
- Wipe off the power plug if it should become covered with dust. Accumulated dust may cause a fire.
- To reduce the risk of hazards, use only CSA/UL certified power supply cord set, cord is Type SPT-2 or heavier, minimum NO.18 AWG copper, one end with a molded-on male attachment plug cap (with a specified NEMA configuration), and the other is provided with a molded-on female connector body (with a specified IEC nonindustrial type configuration) or the equivalent.



### Caution

- Do not place or drop heavy objects on or forcefully bend the AC plug cord. Doing so may damage the cord. Should the AC plug cord be damaged, consult your nearest service center.
- Do not touch or short-circuit the terminal area of the AC plug cord while the cord is plugged in.
- Do not handle the power plug with wet hands. This can cause an electric shock.
- Do not drop the product, or subject it to violent impact. This can cause the product to breakdown.
- Do not use the battery charger D-BC109 to charge batteries other than the rechargeable lithium-ion battery D-LI109. Attempting to charge other types of batteries may cause an explosion or heating, or may damage the battery charger.

## About the Rechargeable Lithium-ion Battery

### **Warning**

- If any leakage from the battery should come in contact with your eyes, do not rub them. Flush your eyes with clean water and get medical attention immediately.

### **Caution**

- Only use the specified battery with this camera. Use of other batteries may cause an explosion or fire.
- Do not disassemble the battery. Disassembling the battery may cause an explosion or leakage.
- Remove the battery from the camera immediately if it becomes hot or begins to smoke. Be careful not to burn yourself during removal.
- Keep wires, hairpins, and other metal objects away from the + and - contacts of the battery.
- Do not short the battery or dispose of the battery in fire. This can cause an explosion or fire.
- If any leakage from the battery should come in contact with skin or clothing, it may cause irritation to the skin. Wash the affected areas thoroughly with water.
- Precautions for D-LI109 Battery Usage:
  - USE SPECIFIED CHARGER ONLY.
  - DO NOT INCINERATE.
  - DO NOT DISASSEMBLE.
  - DO NOT SHORT CIRCUIT.
  - DO NOT EXPOSE TO HIGH TEMP. (140°F / 60°C)

## Keep the Camera and its Accessories out of the Reach of Small Children

### **Warning**

- Do not place the camera and its accessories within the reach of small children.
  1. If the product falls or is operated accidentally, it may cause serious personal injuries.
  2. Wrapping the strap around a neck may cause suffocation.
  3. To avoid the risk of a small accessory such as the battery or memory cards from being swallowed by mistake, keep them out of the reach of small children. Seek medical attention immediately if an accessory is accidentally swallowed.



<b>Introducing the KP</b>	<b>1</b>
<b>Getting Started</b>	<b>2</b>
<b>Taking Pictures</b>	<b>3</b>
<b>Playback Functions</b>	<b>4</b>
<b>Sharing Images</b>	<b>5</b>
<b>Changing the Settings</b>	<b>6</b>
<b>Appendix</b>	<b>7</b>

# How to Use This Manual

## 1

### Introducing the KP.....p.9

Gives you an overview of the KP.  
Read this and get to know your KP!

- Checking the Contents of the Package** .....p.9
- Names and Functions of the Working Parts** .....p.10
- Display Indicators** .....p.13
- How to Change Function Settings** .....p.20
- Menu List** .....p.24

## 2

### Getting Started.....p.36

Explains how to get your KP ready for shooting as well as basic operations.

- Attaching the Strap** .....p.36
- Attaching a Lens** .....p.37
- Using the Battery and Charger** .....p.38
- Inserting a Memory Card** .....p.40
- Adjusting the Angle of the Monitor** .....p.41
- Initial Settings** .....p.42
- Basic Shooting Operation** .....p.44
- Reviewing Images** .....p.47

## 3

### Taking Pictures.....p.48

Once you've confirmed that the camera works properly, try out the camera and take lots of pictures!

- Configuring the Capture Settings** .....p.48
- Taking Still Pictures** .....p.48
- Recording Movies** .....p.52
- Setting the Exposure** .....p.54
- Using the Built-in Flash** .....p.57
- Setting the Focus Method** .....p.59
- Setting the Drive Mode** .....p.64
- Setting the White Balance** .....p.72
- Controlling the Image Finishing Tone** .....p.74
- Correcting Images** .....p.76

## 4

### **Playback Functions**.....p.81

Explains various operations for playing back and editing images.

- Playback Mode Palette Items** ..... p.81
- Changing the Playback Method** ..... p.82
- Editing and Processing Images** ..... p.86

## 5

### **Sharing Images**.....p.92

Explains how to connect your KP to a computer or communication device to operate the camera and use images in the camera.

- Using the Camera with a Computer** ..... p.92
- Using the Camera with a Communication Device** ..... p.93

## 6

### **Changing the Settings** .....p.102

Explains how to change other settings.

- Camera Settings** ..... p.102
- File Management Settings** ..... p.110

## 7

### **Appendix**.....p.115

Provides other resources to get the most from your KP.

- Restrictions on the Combinations of Special Functions** .....p.115
- Functions Available with Various Lenses** ..... p.116
- Functions when Using an External Flash** ..... p.120
- Using the GPS Unit** ..... p.121
- Troubleshooting** .....p.123
- Main Specifications** ..... p.126
- Index** ..... p.133
- Care to be Taken During Handling** ..... p.137
- WARRANTY POLICY** ..... p.141

There is a possibility that the illustrations and the display screen of the monitor in this manual are different from the actual ones.

# Contents

<b>How to Use This Manual .....</b>	<b>4</b>
-------------------------------------	----------

<b>Introducing the KP .....</b>	<b>9</b>
---------------------------------	----------

<b>Checking the Contents of the Package .....</b>	<b>9</b>
---	----------

<b>Names and Functions of the Working Parts ....</b>	<b>10</b>
--	-----------

Operating Controls .....	11
--------------------------	----

<b>Display Indicators .....</b>	<b>13</b>
---------------------------------	-----------

Monitor .....	13
---------------	----

Viewfinder .....	19
------------------	----

Electronic Level .....	20
------------------------	----

<b>How to Change Function Settings .....</b>	<b>20</b>
--	-----------

Using the Direct Keys .....	20
-----------------------------	----

Using the Smart Function .....	21
--------------------------------	----

Using the Control Panel .....	21
-------------------------------	----

Using the Menus .....	23
-----------------------	----

<b>Menu List .....</b>	<b>24</b>
------------------------	-----------

Rec. Mode Menus .....	24
-----------------------	----

Movie Menus .....	29
-------------------	----

Playback Menu .....	31
---------------------	----

Set-up Menus .....	32
--------------------	----

Custom Setting Menus .....	34
----------------------------	----

<b>Getting Started .....</b>	<b>36</b>
------------------------------	-----------

<b>Attaching the Strap .....</b>	<b>36</b>
----------------------------------	-----------

<b>Attaching a Lens .....</b>	<b>37</b>
-------------------------------	-----------

<b>Using the Battery and Charger .....</b>	<b>38</b>
--	-----------

Charging the Battery .....	38
----------------------------	----

Inserting/Removing the Battery .....	39
--------------------------------------	----

Using the AC Adapter .....	40
----------------------------	----

<b>Inserting a Memory Card .....</b>	<b>40</b>
--------------------------------------	-----------

<b>Adjusting the Angle of the Monitor .....</b>	<b>41</b>
---	-----------

<b>Initial Settings .....</b>	<b>42</b>
-------------------------------	-----------

Turning the Camera On .....	42
-----------------------------	----

Setting the Display Language .....	42
------------------------------------	----

Setting the Date and Time .....	43
---------------------------------	----

Setting the LCD Display .....	43
-------------------------------	----

Formatting a Memory Card .....	44
--------------------------------	----

<b>Basic Shooting Operation .....</b>	<b>44</b>
---------------------------------------	-----------

Shooting with the Viewfinder .....	44
------------------------------------	----

Shooting while Viewing the Live View Image .....	46
--	----

<b>Reviewing Images .....</b>	<b>47</b>
-------------------------------	-----------

<b>Taking Pictures .....</b>	<b>48</b>
------------------------------	-----------

<b>Configuring the Capture Settings .....</b>	<b>48</b>
---	-----------

Image Capture Settings .....	48
------------------------------	----

Movie Capture Settings .....	48
------------------------------	----

<b>Taking Still Pictures .....</b>	<b>48</b>
------------------------------------	-----------

Shooting in Exposure Modes .....	49
----------------------------------	----

Using the Electronic Shutter .....	52
------------------------------------	----

<b>Recording Movies .....</b>	<b>52</b>
-------------------------------	-----------

Playing Back Movies .....	54
---------------------------	----

<b>Setting the Exposure .....</b>	<b>54</b>
-----------------------------------	-----------

Sensitivity .....	54
-------------------	----

EV Compensation .....	56
-----------------------	----

AE Metering .....	57
-------------------	----

<b>Using the Built-in Flash .....</b>	<b>57</b>
---------------------------------------	-----------

<b>Setting the Focus Method .....</b>	<b>59</b>
---------------------------------------	-----------

Setting the Autofocus when Shooting with the	
--	--

Viewfinder .....	59
------------------	----

Setting the Autofocus when Shooting with Live	
---	--

View .....	61
------------	----

AF Fine Adjustment .....	63
--------------------------	----

<b>Setting the Drive Mode .....</b>	<b>64</b>
-------------------------------------	-----------

Continuous Shooting .....	65
---------------------------	----

Self-timer .....	65
------------------	----

Bracketing .....	66
------------------	----

Depth of Field Bracketing .....	67
---------------------------------	----

Motion Bracketing .....	68
-------------------------	----

Mirror Lock-up Shooting .....	69
-------------------------------	----



Multi-exposure .....	69	Operating the Camera with a Communication Device .....	94
Interval Shooting .....	70	<b>Changing the Settings .....</b>	<b>102</b>
<b>Setting the White Balance .....</b>	<b>72</b>	<b>Camera Settings .....</b>	<b>102</b>
Adjusting the White Balance Manually .....	73	Customizing the Button/E-dial Functions .....	102
Adjusting the White Balance with Color Temperature .....	73	Setting the Monitor and Indicator Lamps .....	107
<b>Controlling the Image Finishing Tone .....</b>	<b>74</b>	Saving Frequently Used Settings .....	108
Custom Image .....	74	Selecting Settings to Save in the Camera .....	110
Digital Filter .....	75	<b>File Management Settings .....</b>	<b>110</b>
<b>Correcting Images .....</b>	<b>76</b>	Protecting Images from Deletion .....	110
Brightness Adjustment .....	76	Specifying the Folder/File Settings .....	111
Lens Correction .....	77	Setting the Copyright Information .....	113
Quality Level and Texture Adjustment .....	78	Displaying the Local Date and Time of the Specified City .....	114
Composition Adjustment .....	80	<b>Appendix .....</b>	<b>115</b>
<b>Playback Functions .....</b>	<b>81</b>	<b>Restrictions on the Combinations of Special Functions .....</b>	<b>115</b>
<b>Playback Mode Palette Items .....</b>	<b>81</b>	<b>Functions Available with Various Lenses .....</b>	<b>116</b>
<b>Changing the Playback Method .....</b>	<b>82</b>	Using the Aperture Ring .....	118
Displaying Multiple Images .....	82	Performing Catch-in Focus Shooting .....	119
Displaying Images by Folder .....	83	Setting the Focal Length .....	119
Displaying Images by Shooting Date .....	83	<b>Functions when Using an External Flash .....</b>	<b>120</b>
Playing Back Images Continuously .....	84	<b>Using the GPS Unit .....</b>	<b>121</b>
Displaying Rotated Images .....	84	Shooting Celestial Bodies .....	121
Connecting the Camera to an AV Device .....	85	<b>Troubleshooting .....</b>	<b>123</b>
<b>Editing and Processing Images .....</b>	<b>86</b>	Sensor Cleaning .....	124
Changing the Image Size .....	86	Error Messages .....	125
Correcting Color Moiré .....	87	<b>Main Specifications .....</b>	<b>126</b>
Processing Images with Digital Filters .....	87	Operating Environment for USB Connection and Provided Software .....	132
Editing Movies .....	89	<b>Index .....</b>	<b>133</b>
Developing RAW Images .....	90	<b>Care to be Taken During Handling .....</b>	<b>137</b>
<b>Sharing Images .....</b>	<b>92</b>	<b>WARRANTY POLICY .....</b>	<b>141</b>
<b>Using the Camera with a Computer .....</b>	<b>92</b>		
Setting the Connection Mode .....	92		
Copying an Image on the Memory Card .....	92		
Operating the Camera with a Computer .....	93		
<b>Using the Camera with a Communication Device .....</b>	<b>93</b>		
Enabling the Wi-Fi™ Function .....	93		

### Regarding copyrights

Images taken with this camera that are for anything other than personal enjoyment cannot be used without permission according to the rights as specified in the Copyright Act. Please take care, as there are cases where limitations are placed on taking pictures even for personal enjoyment during demonstrations, performances or of items on display. Images taken with the purpose of obtaining copyrights cannot also be used outside the scope of use of the copyright as laid out in the Copyright Act, and care should be taken here also.

### To users of this camera

- Do not use or store this camera in the vicinity of equipment that generates strong electromagnetic radiation or magnetic fields. Strong static charges or the magnetic fields produced by equipment such as radio transmitters could interfere with the monitor, damage the stored data, or affect the camera's internal circuitry and cause camera misoperation.
- The liquid crystal panel used for the monitor is manufactured using extremely high precision technology. Although the level of functioning pixels is 99.99% or better, you should be aware that 0.01% or fewer of the pixels may not light up or may light up when they should not. However, this has no effect on the recorded image.
- The Shake Reduction (SR) mechanism of this camera uses the PENTAX original technology and moves the image sensor to an appropriate position at high speed with a magnetic force, which reduces image blurring caused by camera motion. A rattling sound is made when the camera is shaken, for example, by changing its orientation, but this is not a malfunction.
- In this manual, the generic term "computer(s)" refers to either a Windows® PC or a Macintosh.
- In this manual, the term "battery(ies)" refers to any type of batteries used for this camera and its accessories.

### Regarding User Registration

In order to better serve you, we request that you complete the user registration, which can be found on the CD-ROM supplied with the camera or on our website. Thank you for your cooperation.

<http://www.ricoh-imaging.com/registration/>

# Checking the Contents of the Package



Hot shoe cover Fk  
(Installed on camera)



Eyecup Fr  
(Installed on camera)



Body mount cap K II  
(Installed on camera)



Triangular ring and protective cover  
(Installed on camera)



Battery grip terminal cover  
(Installed on camera)

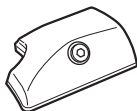

Grip S O-GP167  
(Installed on camera)

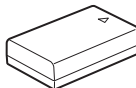

Rechargeable lithium-ion battery D-LI109

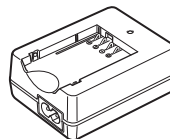

Battery charger D-BC109



AC plug cord

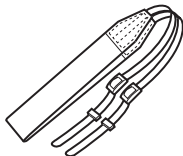

Strap O-ST162

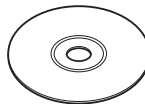

Software (CD-ROM) S-SW167

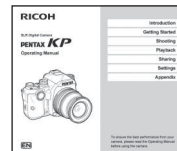

Operating Manual (this manual)

## Lenses you can use

Lenses that can be used with this camera are DA, DA L, D FA, FA J, and FA lenses and lenses that have an **A** (Auto) position on the aperture ring. To use any other lens or accessory, see p.116.

# Names and Functions of the Working Parts





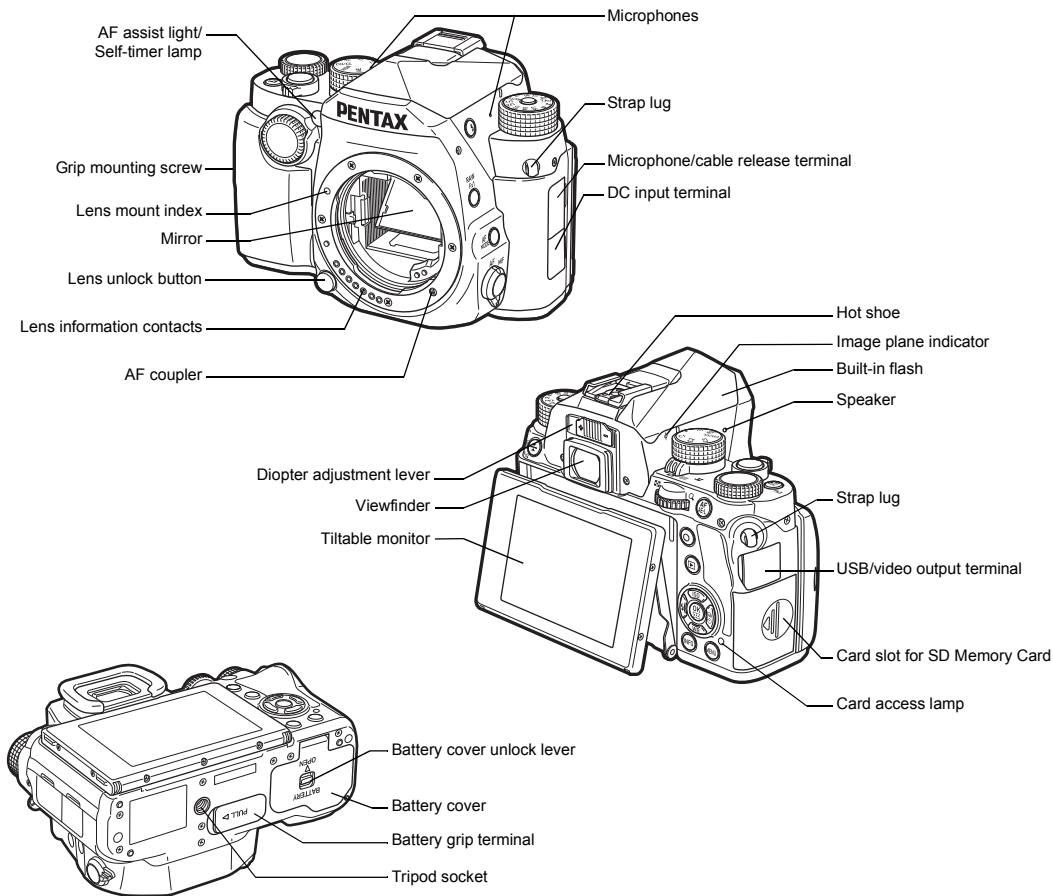

1

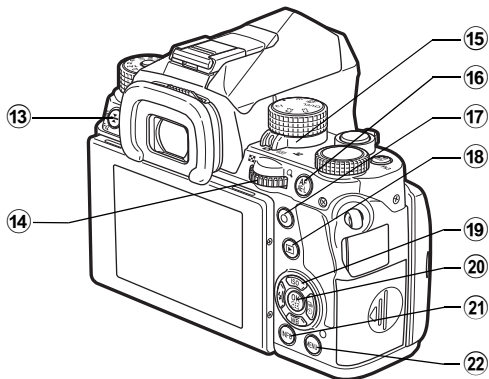
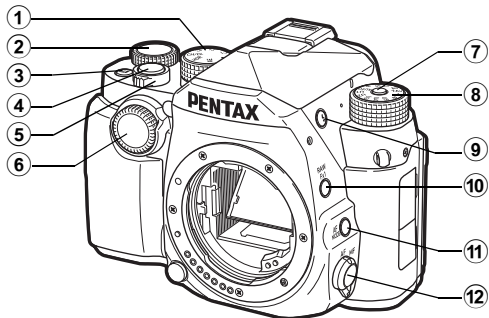











Introduction





## Operating Controls



- ① Function dial**  
Selects the function to change its settings with the setting dial. (Smart Function, p.21)  
You can assign functions to C1, C2, and C3. (p.105)
- ② Setting dial**  
Changes the settings for the function selected with the function dial. (p.21)
- ③ EV Compensation/Fx3 button (  /  )**  
Press to change the exposure compensation value. (p.56)  
You can assign a function to this button. (p.102)  
In playback mode, press to save the last captured JPEG image also in RAW format. (p.47)
- ④ Shutter release button (  )**  
Press to capture images. (p.45)  
In playback mode, press halfway to switch to capture mode.
- ⑤ Main switch**  
Turns the power on or off. (p.42)
- ⑥ Front e-dial (  )**  
Changes the values for camera settings such as exposure. (p.49)  
You can change the menu category when a menu screen is displayed. (p.23)  
In playback mode, use this to select a different image.
- ⑦ Mode dial lock button**  
Press to allow the mode dial to be turned. (p.45)
- ⑧ Mode dial**  
Changes the capture mode. (p.45, p.48)
- ⑨ Flash pop-up button (  )**  
Press to pop up the built-in flash. (p.58)
- ⑩ RAW/Fx1 button (  )**  
Press to temporarily change the file format. (p.103)  
You can assign a function to this button. (p.102)
- ⑪ AF Mode button (  )**  
Press to change the AF mode or AF area. (p.60, p.62)
- ⑫ Focus mode switch ( **AF/MF switch** )**  
Changes the focus method. (p.59)

- 13 Electronic Level/Delete/Fx2 button (  /  / Fx2)**  
Turns the Electronic Level display for the viewfinder and Live View on or off. (p.20)  
In playback mode, press to delete images. (p.47)  
You can assign a function to this button. (p.102)
- 14 Rear e-dial (  )**  
Changes the values for camera settings such as exposure. (p.49)  
You can change the menu tabs when a menu screen is displayed. (p.23)  
You can change camera settings when the control panel is displayed. (p.21)  
In playback mode, use this to magnify the image or display multiple images at the same time. (p.47, p.82)
- 15 Capture mode selector switch (  /LV/  switch)**  
Switches between  (still picture: shooting with the viewfinder) mode, LV (still picture: shooting with Live View) mode, and  (movie) mode. (p.44, p.52)
- 16 AF/AE Lock button (  )**  
Available for adjusting focus, instead of pressing **SHUTTER** halfway, and for locking the exposure value before shooting. (p.51, p.59)
- 17 Green button (  )**  
Resets the value being adjusted.
- 18 Playback button (  )**  
Switches to playback mode. (p.47) Press the button again to switch to capture mode.
- 19 Four-way controller (  )**  
Displays the Sensitivity, White Balance, Flash Mode, or Drive Mode setup menu. (p.20)  
When a menu or the control panel is displayed, use this to move the cursor or change the item to set.  
Press  in single image display of the playback mode to display the playback mode palette. (p.81)

- 20 OK button (  )**  
When a menu or the control panel is displayed, press this button to confirm the selected item.  
Press and hold this button when [AF Active Area] is set to [Select], [Expanded Area AF], or [Multiple AF Points] to switch the function of the arrow keys to AF area change mode or direct key operation mode. (p.60, p.62)
- 21 INFO button (  )**  
Changes the style of the display on the monitor. (p.13, p.17)
- 22 MENU button (  )**  
Displays a menu. Press this button while the menu is displayed to return to the previous screen. (p.23)

### About the Four-way Controller

In this manual, each button of the four-way controller is indicated as shown in the illustration on the right.

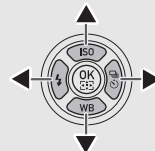

# Display Indicators

## Monitor

### Capture Mode

With this camera, you can take pictures while looking through the viewfinder or while viewing the image on the monitor. When using the viewfinder, you can take pictures while checking the status screen displayed on the monitor and looking through the viewfinder. (p.44) When not using the viewfinder, you can take pictures while viewing the Live View image displayed on the monitor. (p.46)

The camera is in “standby mode” when it is ready to shoot, such as when the status screen or Live View image is displayed. Press **INFO** in standby mode to display the “control panel” and change settings. (p.21) You can change the type of information displayed in standby mode by pressing **INFO** while the control panel is displayed. (p.16)

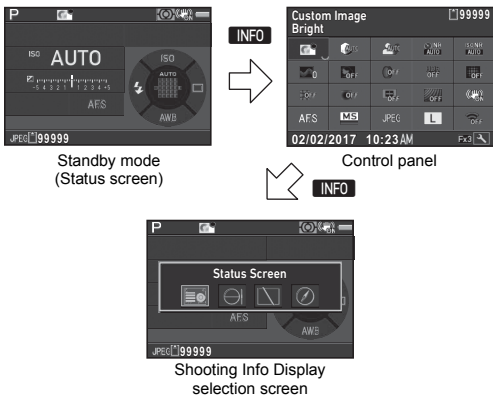

### Memo

- You can set the display color of the status screen, control panel, and menu cursor in “Initial Settings” (p.42).

## Standby Mode

The settings for shooting are displayed.

## Status Screen

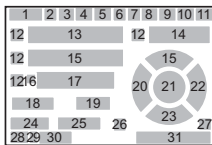

## Live View

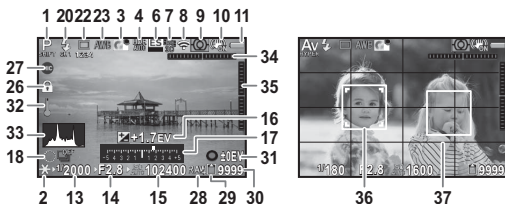

- |  |   |
|--|---|
| 1 Capture mode (p.48)  | 10 Shake Reduction/<br>Horizon Correction/<br>Movie SR/Composition<br>Adjustment (p.80) |
| 2 AE Lock (p.51)   | 11 Battery level  |
| 3 Custom Image (p.74)  | 12 E-dial guide   |
| 4 Clarity (p.78)/Skin Tone<br>(p.78)/Digital Filter<br>(p.75)/HDR Capture<br>(p.77)/Pixel Shift<br>Resolution (p.78) | 13 Shutter speed  |
| 5 AA Filter Simulator (p.79)   | 14 Aperture value   |
| 6 Electronic Shutter (p.52)  | 15 Sensitivity (p.54)   |
| 7 GPS positioning status<br>(p.121)  | 16 EV Compensation<br>(p.56)/Bracketing (p.66)  |
| 8 Wi-Fi™ connection<br>status (p.93)   | 17 EV bar scale   |
| 9 AE Metering (p.57)   | 18 Operation guide for<br>Smart Function (p.21)   |
|  | 19 Focus Method (p.59)  |

- |   |  |
|---|--|
| 20 Flash Mode (p.57)/<br>Wireless mode channel<br>(p.120)                                 | 28 File Format (p.48)  |
| 21 Focusing area (AF point)<br>(p.60)   | 29 Memory card   |
| 22 Drive Mode (p.64)/<br>Number of shots during<br>Multi-exposure or<br>Interval Shooting | 30 Number of recordable<br>still pictures/Movie<br>recordable time                         |
| 23 White Balance (p.72)   | 31 Operation guide   |
| 24 Flash Exposure<br>Compensation (p.57)  | 32 Temperature warning   |
| 25 White Balance fine-<br>tuning (p.72)   | 33 Histogram   |
| 26 Operation Control Lock<br>(p.51)   | 34 Electronic Level<br>(horizontal tilt) (p.20)  |
| 27 External Input Devices<br>(p.53)   | 35 Electronic Level (vertical<br>tilt) (p.20)  |
|   | 36 Face detection frame<br>(when [AF Active Area] is<br>set to [Face Detection])<br>(p.62) |
|   | 37 Grid Display (p.26, p.29)<br>(p.53)   |

## Memo

- In [Live View] of the 5 and 2 menus, you can change the display settings of Live View. (p.26, p.29)



## Control Panel

The following functions are displayed with the default setting.

### mode

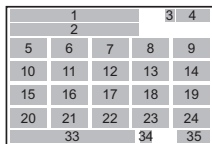
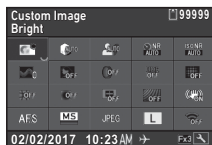

### mode

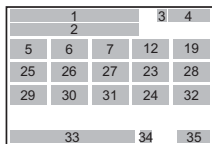
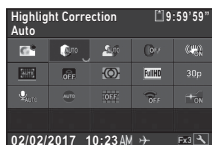

- 1 Function name
- 2 Setting
- 3 Memory card
- 4 Number of recordable still pictures/Movie recordable time
- 5 Custom Image (p.74)
- 6 Highlight Correction (p.76)
- 7 Shadow Correction (p.76)
- 8 Slow Shutter Speed NR (p.50)
- 9 High-ISO NR (p.55)
- 10 Clarity (p.78)
- 11 Skin Tone (p.78)
- 12 Digital Filter (p.75)
- 13 HDR Capture (p.77)
- 14 Pixel Shift Resolution (p.78)
- 15 Distortion Correction (p.77)
- 16 Peripheral Illumination Correction (p.77)
- 17 Horizon Correction
- 18 AA Filter Simulator (p.79)
- 19 Shake Reduction/Movie SR
- 20 AF Mode (p.60, p.62)
- 21 Shutter Mode Selection (p.52)
- 22 File Format (p.48)
- 23 JPEG Recorded Pixels (p.48)/Movie Recorded Pixels (p.48)
- 24 Wi-Fi (p.94)
- 25 AF Active Area (p.60, p.62)
- 26 Focus Peaking (p.61)
- 27 AE Metering (p.57)

- 28 Framerate (p.48)
- 29 Recording Sound Level (p.53)
- 30 External Input Devices (p.53)
- 31 Grid Display (p.29)
- 32 AF Assist Light (p.24)
- 33 Current date and time (p.114)
- 34 Destination (p.114)
- 35 Operation guide for the control panel customization (p.22)

### Memo

- Refer to “Using the Control Panel” (p.21) for how to use the control panel.
- The functions displayed on the control panel can be customized. (p.22)

## Shooting Info Display

You can change the type of information displayed in standby mode by pressing **INFO** while the control panel is displayed. Use **◀▶** to select the type and press **OK**.

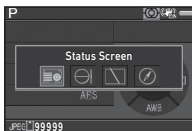

## When shooting with the viewfinder

<b>Status Screen</b>	Displays the settings for shooting with the viewfinder. (p.14)	
<b>Electronic Level</b>	Displays the camera angle. A bar scale indicating the horizontal camera angle appears at the center of the screen, and a bar scale indicating the vertical camera angle appears on the right side. When the angle exceeds the range that can be displayed in each scale, the indicator segments of the scale are displayed in red.	<p>Example: Tilted 1.5° to the left (yellow) Vertically level (green)</p>
<b>Display Off</b>	Nothing is displayed on the monitor.	
<b>Electronic Compass</b>	Displays the current latitude, longitude, altitude, direction, Coordinated Universal Time (UTC), capture mode, and exposure value. Turn the camera off and on again to return to the status screen. Available only when the optional GPS unit is attached to the camera and is operating. (p.121)	

## When shooting with Live View

<b>Standard Information Display</b>	The Live View image and the settings for shooting with Live View are displayed. (p.14)
<b>Electronic Level</b>	The same electronic level as when shooting with the viewfinder is displayed.
<b>No Information Display</b>	Certain icons, such as those for the capture mode and drive mode, are not displayed.

## Memo

- The status screen is displayed when the camera is turned off and on again. If [Shooting Info Display] is set to (On) in [Memory] of the 5 menu, the screen selected on the Shooting Info Display selection screen appears when the camera is turned off and on again. (p.110)
- When [LCD Display Options] is assigned to the function dial, you can switch the display using the Smart Function. (p.21, p.105)

## Playback Mode

The captured image and shooting information are displayed in single image display of the playback mode.

Press **INFO** to change the type of information displayed in single image display. Use **◀▶** to select the type and press **OK**.



Single image display  
(Standard Information Display)

Playback Info Display  
selection screen

<b>Standard Information Display</b>	Captured image, file format, exposure parameters, and operation guide indicators are displayed.
<b>Detailed Information Display</b>	Detailed information on how and when the image was taken is displayed. (p.17)
<b>Histogram Display</b>	Captured image and brightness histogram are displayed. (p.18) Not available during movie playback.
<b>RGB Histogram Display</b>	Captured image and RGB histogram are displayed. (p.18) Not available during movie playback.
<b>No Information Display</b>	Only the captured image is displayed.

### Memo

- You can set overexposed areas to blink red in Standard Information Display, Histogram Display, and No Information Display. Set in [Highlight Alert] of [LCD Display] in the **1** menu. (p.31)
- The screen selected on the Playback Info Display selection screen is displayed in playback mode when the camera is turned off and on again. If [Playback Info Display] is set to **0** (Off) in [Memory] of the **5** menu, the Standard Information Display always appears first when the camera is turned on. (p.110)
- When [LCD Display Options] is assigned to the function dial, you can switch the display using the Smart Function. (p.21, p.105)

## Detailed Information Display

### Still pictures

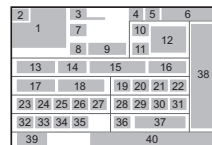

### Movie

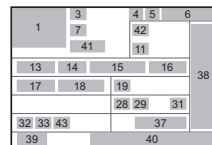

### Page 2



- Captured image
- Rotation information (p.84)
- Capture mode (p.48)
- Wi-Fi™ connection status (p.93)
- Protect setting (p.110)
- Folder number-File number (p.111)
- Drive Mode (p.64)
- Flash Mode (p.57)
- Flash Exposure Compensation (p.57)
- Focus Method (p.59)
- AE Metering (p.57)
- Focusing area (AF point) (p.60)
- Shutter speed
- Aperture value
- Sensitivity (p.54)
- EV Compensation (p.56)
- White Balance (p.72)
- White Balance fine-tuning (p.72)
- Digital Filter (p.75)

- 20 HDR Capture (p.77)/ Pixel Shift Resolution (p.78)
- 21 Clarity (p.78)
- 22 Skin Tone (p.78)
- 23 Distortion Correction (p.77)
- 24 Peripheral Illumination Correction (p.77)
- 25 Lateral Chromatic Aberration Adjustment (p.77)
- 26 Diffraction Correction (p.77)
- 27 Color Fringe Correction (p.90)
- 28 Highlight Correction (p.76)
- 29 Shadow Correction (p.76)
- 30 AA Filter Simulator (p.79)
- 31 Shake Reduction/ Horizon Correction/ Movie SR
- 32 File Format (p.48)
- 33 JPEG Recorded Pixels (p.48)/Movie Recorded Pixels (p.48)
- 34 JPEG Quality (p.48)
- 35 Color Space (p.48)
- 36 Color Moiré Correction (p.87)
- 37 Lens focal length
- 38 Custom Image (p.74)
- 39 Operation guide
- 40 Shooting date and time
- 41 Length of time of the recorded movie
- 42 Recording Sound Level (p.53)
- 43 Framerate (p.48)
- 44 Tampered image warning
- 45 Photographer (p.113)
- 46 Copyright Holder (p.113)
- 47 Altitude
- 48 Lens direction
- 49 Latitude
- 50 Longitude
- 51 Universal Coordinated Time

## Histogram Display

Use ▲▼ to switch between the brightness histogram and RGB histogram.

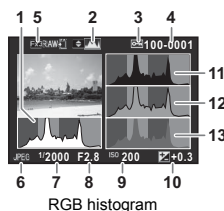
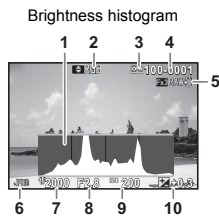

- 1 Histogram (Brightness)
- 2 RGB histogram/  
Brightness histogram
- 3 Protect setting
- 4 Folder number-File  
number
- 5 Save RAW Data
- 6 File Format
- 7 Shutter speed
- 8 Aperture value
- 9 Sensitivity
- 10 EV Compensation
- 11 Histogram (R)
- 12 Histogram (G)
- 13 Histogram (B)

## Viewfinder

When shooting with the viewfinder, information appears in the viewfinder.

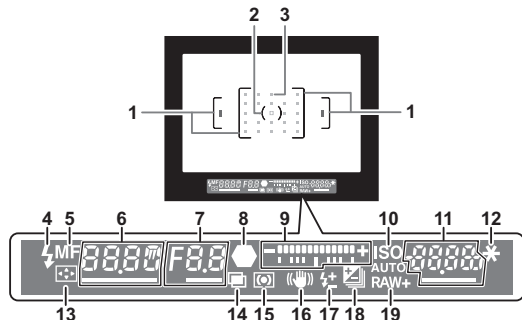

- |   |  |
|---|--|
| 1 AF frame (p.45)   | 11 Sensitivity (p.54)/<br>Exposure compensation<br>value/Image storage<br>capacity/Wireless mode<br>channel (p.120)/AF<br>Active Area (p.60) |
| 2 Spot metering frame<br>(p.57)   | ⌘-⌘ Auto (27 AF<br>Points)   |
| 3 AF point (p.60)   | ⌘-⌘ Zone Select  |
| 4 Flash indicator (p.57)  | ⌘⌘⌘ Select   |
| 5 Focus Method (p.59)   | ⌘⌘⌘ Expanded Area<br>AF (S)  |
| 6 Shutter speed/AF Mode<br>(p.60)/Exposure time for<br>timed exposure in <b>B</b><br>mode/Number of shots<br>for Bracketing | ⌘⌘⌘ Expanded Area<br>AF (M)  |
| 7 Aperture value/Bracket<br>value for Bracketing  | ⌘⌘⌘ Expanded Area<br>AF (L)  |
| 8 Focus indicator (p.45)  | ⌘⌘⌘ Spot   |
| 9 EV bar scale/Electronic<br>Level (p.20)   | 12 AE Lock   |
| 10 ISO/ISO AUTO   | 13 Change AF Area (p.60)   |

- |  |  |
|--|--|
| 14 Multi-exposure (p.69)                 | 18 EV Compensation<br>(p.56)/Bracketing (p.66) |
| 15 AE Metering (p.57)                    | 19 File Format (p.48)                          |
| 16 Shake Reduction                       |  |
| 17 Flash Exposure<br>Compensation (p.57) |  |

### Memo

- The information is displayed in the viewfinder when **SHUTTER** is pressed halfway, or during the meter operating time (default setting: 10 sec.). You can change the meter operating time in [3 Meter Operating Time] of the **C1** menu. (p.34)
- The AF point in use for autofocus appears in red (Superimpose AF Area) when **SHUTTER** is pressed halfway. You can turn this function off in [Superimpose AF Area] of [Viewfinder Overlay] in the **M5** menu. (p.26)
- You can adjust the viewfinder image sharpness using the diopter adjustment lever. If it is difficult to move the diopter adjustment lever, lift up and remove the eyecup. Adjust the diopter setting until the AF frame in the viewfinder looks sharp and clear.

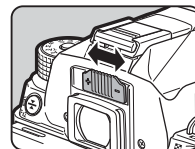

## Electronic Level

You can check whether the camera is tilted by displaying electronic levels. The electronic level for the horizontal camera angle can be displayed in the viewfinder, and the electronic levels for the vertical and horizontal camera angles can be displayed on the Live View screen. (p.14) Use  to turn the display on or off.



### Examples of Electronic Level in the Viewfinder

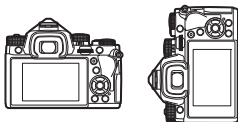

When level (at 0°)







When tilted 5° to the left



When held vertically and tilted 3° to the right











### Memo

- You can assign a different function to  (Fn2). Also, you can assign [Electronic Level] to  or . (p.102)
- You can select whether to display the electronic levels in [Viewfinder Overlay] and [Live View] of the 5 menu. (p.26)

## How to Change Function Settings

### Using the Direct Keys

Press     in standby mode.

	<b>Sensitivity</b>	p.54
	<b>White Balance</b>	p.72
	<b>Flash Mode</b>	p.57
	<b>Drive Mode</b>	p.64

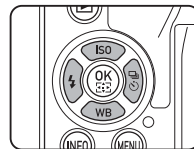

## Using the Smart Function

You can easily change settings with two dials: the function dial and the setting dial. Use the function dial (①) to select the desired function, and use the setting dial (②) to change its setting value.

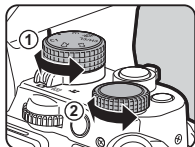

The following functions can be selected.

Function Dial	Function	Page
●	Disables the setting dial operation.	—
<b>AE</b>	Changes the AE Metering method.	p.57
<b>HDR</b>	Changes the capture type of HDR Capture.	p.77
<b>CH/CL</b>	Changes the shooting speed for Continuous Shooting.	p.65
<b>C1</b>	Changes the image finishing tone for Custom Image (default setting).	p.74
<b>C2</b>	Changes the capture type of AA Filter Simulator (default setting).	p.79
<b>C3</b>	Changes the brightness of the monitor (default setting).	p.108

You can assign functions to C1, C2, and C3 in [Button Customization] of the menu. (p.105)

The assigned functions can be checked on the status screen or Live View screen when the function dial or setting dial is turned.

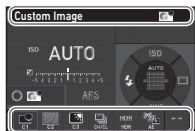

## Using the Control Panel

Press **INFO** in standby mode.

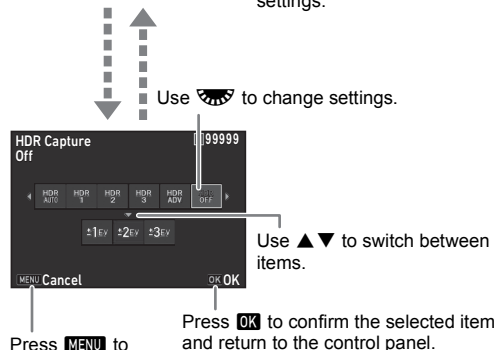
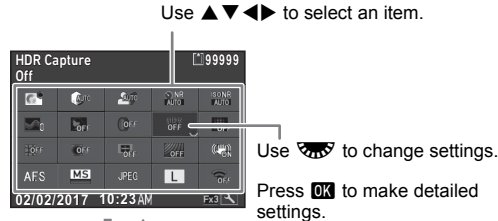



Press **MENU** to cancel the setting operation.

### Memo

- The functions that can be selected vary depending on the current camera settings.
- If no operations are made within approximately 1 minute while the control panel is displayed, the camera returns to standby mode.

## Customizing the Control Panel

The functions displayed on the control panel can be customized.

Some functions in the , , and  menus can be saved as control panel items. Refer to “Menu List” (p.24) for details on the functions that can be saved.

### 1 Press **INFO** in standby mode.

The control panel appears.

### 2 Press **Fx3**.

The customization screen appears.

### 3 Use **▲▼◀▶** to select the function to change.

Press **○** to reset to the default settings.

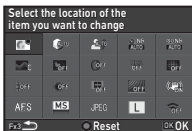

### 4 Press **OK**.

Selectable functions are displayed in the pop-up menu.

### 5 Use **▲▼** to select the function to save.

Select **--** if you do not want to save any function.

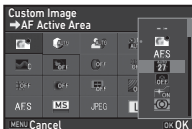

### 6 Press **OK**.

The screen of Step 3 reappears.

### 7 Press **Fx3**.

The control panel reappears.

### 8 Press **MENU**.

The camera returns to standby mode.



## Using the Menus

Most functions are set from the menus.

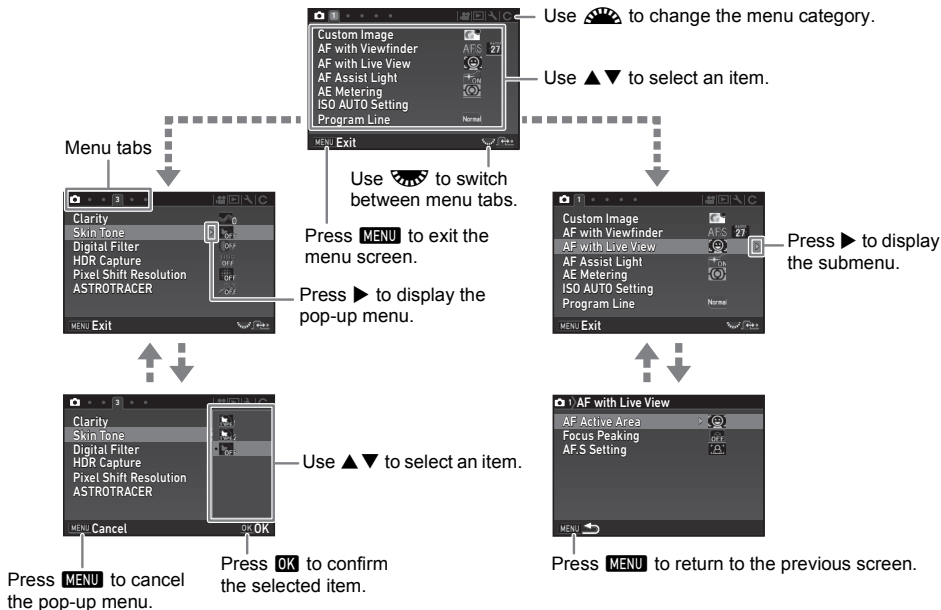

### Memo

- For the Custom Setting menu (C menu), you can display the setting screen of the next item in order of the menu list by turning while the submenu of the currently selected item is displayed on the monitor.
- Press **MENU** to display the first tab of the most appropriate menus for the camera settings at that time. To display the menu tab last selected first, set in [21 Save Menu Location] of the **C3** menu.
- The settings changed with the menus, direction keys, Smart Function, control panel, and playback mode palette are returned to their default values with [Reset] of the menu. To reset the setting values of the Custom Setting menu items to the defaults, use [Reset Custom Functions] of the **C4** menu. (Some settings do not apply.)

# Menu List

1





Introduction

## Rec. Mode Menus

Item		Function	Default Setting	Page
	<b>Custom Image</b> *1 *2	Sets the image finishing tone such as color and contrast before shooting an image.	Bright	p.74
AF with Viewfinder	<b>AF Mode</b> *1 *2	Selects the autofocus mode for shooting with the viewfinder.	<b>A.F.S</b>	p.60
	<b>AF Active Area</b> *1 *2	Selects the area to adjust the focus for shooting with the viewfinder.	Auto (27 AF Points)	p.60
	<b>A.F.S Setting</b>	Sets the action priority for when the autofocus mode is set to <b>A.F.S</b> and <b>SHUTTER</b> is fully pressed.	Focus-priority	p.59
	<b>1st Frame Action in A.F.C</b>	Sets the action priority for the first frame when the autofocus mode is set to <b>A.F.C</b> and <b>SHUTTER</b> is fully pressed.	Auto	
	<b>Action in A.F.C Cont.</b>	Sets the action priority during Continuous Shooting when the autofocus mode is set to <b>A.F.C</b> .	Auto	
	<b>Hold AF Status</b>	Maintains the focus for a certain amount of time when the subject happens to move out of the selected focusing area after being focused.	Low	
AF with Live View	<b>AF Active Area</b> *1 *2	Selects the area to adjust the focus for shooting with Live View.	Face Detection	p.62
	<b>Focus Peaking</b> *1 *2	Emphasizes the outline and contrast of the subject in focus and makes it easier to check the focus.	Off	p.61
	<b>A.F.S Setting</b>	Sets the action priority for when <b>SHUTTER</b> is fully pressed.	Focus-priority	
	<b>AF Assist Light</b> *1	Illuminates the assist light when autofocusing in dark locations.	On	p.60
	<b>AE Metering</b> *1	Selects the part of the sensor to use for measuring brightness and determining the exposure.	Multi-segment	p.57
ISO AUTO Setting	<b>ISO Range (Maximum)</b> *1	Sets the upper limit value for ISO AUTO.	ISO 6400	p.55
	<b>ISO Range (Minimum)</b>	Sets the lower limit value for ISO AUTO.	ISO 100	
	<b>ISO Sensitivity Options</b> *1	Sets whether to set the minimum shutter speed automatically or manually.	AUTO	
	<b>Minimum Shutter Speed</b>	Selects the shutter speed option or sets the minimum shutter speed.	Std.	

	Item	Function	Default Setting	Page	
📷1	Program Line *1 *2	Selects the Program Line setting.	Std.	p.50	
	Exposure Mode *3	Exposure Mode	Temporarily changes the exposure mode when the mode dial is set to one of the modes from <b>U1</b> to <b>U5</b> .	<b>P</b>	p.109
		Program Line	Selects the Program Line setting when the mode dial is set to one of the modes from <b>U1</b> to <b>U5</b> .	Std.	
📷2	Shutter Mode Selection *1 *2	Switches between the mechanical shutter and the electronic shutter.	Mechanical Shutter	p.52	
	Image Capture Settings	File Format *1	Sets the file format of images.	JPEG	p.48
		JPEG Recorded Pixels *1 *2	Sets the recording size of JPEG images.	<input type="checkbox"/>	
		JPEG Quality *1	Sets the quality of JPEG images.	★★★	
		RAW File Format	Sets the RAW file format.	PEF	
		Color Space	Sets the color space to use.	sRGB	
	D-Range Settings	Highlight Correction *1	Expands the dynamic range and prevents overexposed areas from occurring.	Auto	p.76
		Shadow Correction *1	Expands the dynamic range and prevents underexposed areas from occurring.	Auto	
	Noise Reduction	Slow Shutter Speed NR *1	Sets the Noise Reduction setting when shooting with a slow shutter speed.	Auto	p.50
High-ISO NR *1		Sets the Noise Reduction setting when shooting with a high ISO sensitivity.	Auto	p.55	
📷3	Clarity *1	Changes the clarity of images using an image processing program.	±0	p.78	
	Skin Tone *1	Enhances the skin tone of the subject in the image using an image processing program.	Off	p.78	
	Digital Filter *1	Applies a digital filter effect when taking pictures.	No Filter	p.75	
	HDR Capture	HDR Capture *1	Makes settings for high dynamic range shooting.	Off	p.77
		Bracket Value		±2EV	
		Auto Align		On	
	Pixel Shift Resolution	Pixel Shift Resolution	Merges multiple images and outputs a high-definition image.	Off	p.78
		Motion Correction *1		On	
	ASTROTRACER *1	Makes settings to track and capture celestial bodies.	Off	p.121	

	Item	Function	Default Setting	Page	
📷4	<b>AA Filter Simulator</b> *1 *2	Applies a low-pass filter effect using the Shake Reduction mechanism.	Off	p.79	
	<b>Shake Reduction</b> *1	Activates the Shake Reduction function.	On	–	
	<b>Horizon Correction</b> *1	Corrects horizontal tilt when in 📷 mode.	Off	–	
	<b>Composition Adjust.</b> *1	Allows you to adjust the composition of your image using the Shake Reduction mechanism.	Off	p.80	
	<b>Lens Correction</b>	<b>Distortion Correction</b> *1	Reduces distortions occurring due to lens properties.	Off	p.77
		<b>Peripheral Illumin. Corr.</b> *1	Reduces peripheral light fall-off occurring due to lens properties.	Off	
		<b>Lat-Chromatic-Ab Adj</b> *1	Reduces lateral chromatic aberrations occurring due to lens properties.	On	
<b>Diffraction Correction</b> *1		Corrects blur caused by diffraction when using a small aperture.	On		
<b>Input Focal Length</b> *1	Sets the focal length when using a lens of which focal length information cannot be obtained.	35mm	p.119		
📷5	<b>Viewfinder Overlay</b>	<b>Electronic Level</b> *1	Displays the electronic level at the bottom of the viewfinder.	Off	p.20
		<b>Superimpose AF Area</b>	Displays the active AF point in red in the viewfinder.	On	p.19
	<b>Live View</b>	<b>Grid Display</b> *1 *2	Sets the type and color of the grid lines displayed during Live View.	Off, Black	p.46
		<b>Electronic Level</b> *1	Displays the electronic level during Live View.	On	
		<b>Histogram Display</b>	Displays the histogram during Live View.	Off	
		<b>Highlight Alert</b>	Sets overexposed areas to blink red during Live View.	Off	
		<b>Flicker Reduction</b>	Cuts down on the Live View screen flicker by setting the power frequency.	50Hz	
	<b>Instant Review</b>	<b>Display Time</b>	Sets the Instant Review display time.	1sec.	p.45
		<b>Zoom Review</b>	Displays the magnified image during Instant Review.	On	
		<b>Save RAW Data</b>	Saves the RAW data during Instant Review.	On	
		<b>Delete</b>	Deletes the displayed image during Instant Review.	On	
<b>Histogram Display</b>		Displays the histogram during Instant Review.	Off		
<b>Highlight Alert</b>	Sets overexposed areas to blink red during Instant Review.	Off			

		Item	Function	Default Setting	Page	
5	Other Display Settings	Guide Display	Displays operation guides on the status screen and Live View screen when the buttons and dials are operated.	On	p.45	
		Display Color	Sets the display color of the status screen, control panel, and menu cursor.	1	p.43	
	Button Customization	Fx1 Button	Sets the function for when <b>Fx1</b> is pressed.	One Push File Format	p.102	
		Fx2 Button	Sets the function for when <b>Fx2</b> is pressed.	Electronic Level		
		Fx3 button	Sets the function for when <b>Fx3</b> is pressed.	EV Compensation		
		AF/AE-L Button	Sets the function for when <b>AF/AE-L</b> is pressed.	Enable AF1		
		Function Dial	C1	Assigns the functions to C1, C2, and C3 of the function dial.	Custom Image	p.105
			C2		AA Filter Simulator	
			C3		Outdoor View Setting	
		E-Dial Programming	P	Sets the  /  /  operation for each exposure mode.	<b>Tv, Av, →P</b>	p.106
			Sv		-, ISO, -	
			Tv		<b>Tv, -, -</b>	
	Av		-, <b>Av, -</b>			
	TAv		<b>Tv, Av, P</b> LINE			
	M		<b>Tv, Av, P</b> LINE			
	Rotation Direction		Reverses the effect obtained when  or  is turned.		Rotate Right	
	Memory	Sensitivity	Determines which settings to save when the power is turned off.	On	p.110	
		EV Compensation		On		
		Flash Mode		On		
		Flash Exposure Comp.		On		
Drive Mode		On				
White Balance		On				
Custom Image		On				
Clarity		Off				

	Item	Function	Default Setting	Page	
☑5	Memory	Skin Tone	Determines which settings to save when the power is turned off.	Off	p.110
		Digital Filter		Off	
		HDR Capture		Off	
		Pixel Shift Resolution		Off	
		Composition Adjust.		On	
		Shooting Info Display		Off	
		Playback Info Display		On	
		Outdoor View Setting		Off	
		Night Vision LCD Display		Off	
		Operation Control Lock		On	
		Save USER Mode		Save Settings	
Rename USER Mode	Changes the names of the saved USER modes to display on the monitor.		HDR LANDSCAPE, MACRO, ASTROPHOTO, MANUAL LENS, USER5		
Check Saved Settings	Displays the settings saved in USER modes.		–		
Reset USER Mode	Resets all the settings saved in USER modes to the defaults.				

\*1 Available as a control panel item.

\*2 Available as a function of the function dial.

\*3 The function appears only in **U1** to **U5** modes.

## Movie Menus

	Item	Function	Default Setting	Page	
1	<b>Custom Image</b> *1 *2	Sets the image finishing tone such as color and contrast before shooting a movie.	Bright	p.74	
	<b>AF with Live View</b>	<b>AF Mode</b> *1 *2	Selects the autofocus mode for movie recording.	<b>A.F.S</b>	p.62
		<b>AF Active Area</b> *1 *2	Selects the area to adjust the focus for movie recording.	Multiple AF Points	p.62
		<b>Focus Peaking</b> *1 *2	Emphasizes the outline and contrast of the subject in focus and makes it easier to check the focus.	Off	p.61
	<b>AF Assist Light</b> *1	Illuminates the assist light when autofocusing in dark locations.	On	p.60	
	<b>AE Metering</b> *1	Selects the part of the sensor to use for measuring brightness and determining the exposure.	Multi-segment	p.57	
	<b>Movie Capture Settings</b>	<b>Recorded Pixels</b> *1 *2	Sets the number of recorded pixels of the movie.		p.48
<b>Framerate</b> *1		Sets the frame rate of the movie.	30p		
	<b>Recording Sound Level</b> *1	Sets the sound volume level for recording.	Auto	p.53	
2	<b>D-Range Settings</b>	<b>Highlight Correction</b> *1	Expands the dynamic range and prevents overexposed areas from occurring.	Auto	p.76
		<b>Shadow Correction</b> *1	Expands the dynamic range and prevents underexposed areas from occurring.	Auto	
	<b>Digital Filter</b> *1	Applies a digital filter effect when recording a movie.	No Filter	p.75	
	<b>Movie SR</b> *1	Activates the Shake Reduction function.	On	–	
	<b>Live View</b>	<b>Grid Display</b> *1 *2	Sets the type and color of the grid lines displayed during Live View.	Off, Black	p.14
		<b>Electronic Level</b> *1	Displays the electronic level during Live View.	On	
<b>Histogram Display</b>		Displays the histogram during Live View.	Off		
<b>Highlight Alert</b>		Sets overexposed areas to blink red during Live View.	Off		
	<b>Flicker Reduction</b>	Cuts down on the Live View screen flicker by setting the power frequency.	50Hz		

		Item	Function	Default Setting	Page	
2  <b>Button Customization</b>	<b>E-Dial Programming</b>	<b>AF/AE-L Button</b>	Sets the function for when <b>AF/AE-L</b> is pressed.	Enable AF1	p.102	
				Sets the  /  /  operation for each exposure mode.	-, -, -	p.106
					<b>Tv</b> , -, <b>P</b> LINE	
					-, <b>Av</b> , <b>P</b> LINE	
					<b>Tv</b> , <b>Av</b> , <b>P</b> LINE	
<b>Rotation Direction</b>	Reverses the effect obtained when  or  is turned.	Rotate Right				

\*1 Available as a control panel item.





\*2 Available as a function of the function dial.



## Playback Menu

	Item	Function	Default Setting	Page	
☐1	<b>Slideshow</b>	<b>Display Duration</b>	Sets an image display interval.	3sec.	p.84
		<b>Screen Effect</b>	Sets a transition effect when the next image is displayed.	Off	
		<b>Repeat Playback</b>	Starts a slideshow again from the beginning after the last image is displayed.	Off	
		<b>Auto Movie Playback</b>	Plays back movies during a slideshow.	On	
	<b>Protect All Images</b>	Protects all stored images at once.	–	p.110	
	<b>Delete All Images</b>	Deletes all stored images at once.	–	–	
	<b>Quick Zoom</b>	Sets the initial magnification when magnifying images.	Off	p.47	
	<b>Playback Sound Volume</b>	Sets the sound volume during movie playback.	10	p.54	
	<b>LCD Display</b>	<b>Auto Image Rotation</b>	Rotates images which were captured with the camera held vertically or of which the rotation information has been changed.	On	p.84
		<b>Grid Display</b>	Sets the type and color of grid lines.	Off, Black	p.47
<b>Highlight Alert</b>		Sets overexposed areas to blink red in Standard Information Display, Histogram Display, and No Information Display of the playback mode.	Off	p.17	

	Item	Function	Default Setting	Page	
1	<b>Language/言語</b>	Changes the display language.	English	p.42	
	<b>Date Adjustment</b>	Sets the date and time and the display format.	01/01/2017	p.43	
	<b>World Time</b>	Switches between the date and time display of your hometown city and that of a specified city.	Hometown	p.114	
	<b>Text Size</b>	Magnifies the text size when selecting a menu item.	Std.	p.42	
	<b>Sound Effects</b>	<b>Volume</b>	Sets the sound volume of beep sounds.	3	–
		<b>In-focus</b>	Sets whether to make a beep sound when the subject is focused.	On	p.45
		<b>AE-L</b>	Sets whether to make a beep sound when the exposure value is locked with <b>[AF/AE-L]</b> .	On	p.51
		<b>Self-timer</b>	Sets whether to make a beep sound during the countdown for Self-timer shooting.	On	p.65
		<b>Mirror Up</b>	Sets whether to make a beep sound during Mirror Lock-up Shooting.	On	p.69
		<b>Change AF Area</b>	Sets whether to make a beep sound when the function of the arrow keys ( <b>▲▼◀▶</b> ) is switched to AF area change mode.	On	p.61
<b>One Push File Format</b>		Sets whether to make a beep sound when the file format is changed with <b>[Fxi]</b> , <b>[F2]</b> , or <b>[F3]</b> .	On	p.103	
<b>Electronic Level</b>		Sets whether to make a beep sound when the Electronic Level display is turned on or off with <b>[Fxi]</b> , <b>[F2]</b> , or <b>[F3]</b> .	On	p.20	
<b>Wi-Fi</b>		Sets whether to make a beep sound when the Wi-Fi™ function is turned on or off with <b>[Fxi]</b> .	On	p.94	
	<b>Night Vision LCD Display</b>	Sets whether to make a beep sound when the Night Vision LCD Display feature is turned on or off with <b>[Fxi]</b> .	On	p.122	
2	<b>LCD Display Settings</b>		Sets the brightness, saturation, and color adjustment of the monitor.	0	p.107
	<b>Outdoor View Setting</b> *1 *2		Adjusts the brightness of the monitor for outdoor shooting.	Off	p.108
	<b>Night Vision LCD Display</b> *1		Changes the monitor display color to red for shooting in a dark place such as night-time shooting.	Off	p.122
	<b>Indicator Lamps</b>	<b>Self-timer</b>	Sets whether to make the self-timer lamp blinking during the countdown for the drive mode [Self-timer].	On	p.108
		<b>GPS LED Indicators</b>	Sets whether to light up the indicator lamps on the GPS unit when it is attached to the camera.	On	

	Item	Function	Default Setting	Page	
3	Wi-Fi *1	Activates the Wi-Fi™ function.	Off	p.94	
	GPS/E-Compass	GPS Time Sync	Automatically adjusts the date and time settings.	On	p.121
		Calibration	Performs a calibration of direction information.	–	
	USB Connection	Sets the USB connection mode when connecting to a computer with a commercially available USB cable.	MSC	p.92	
	Video Out Resolution	Sets the output format when connecting to an AV device via the video output terminal.	Auto	p.85	
	External Input Devices *1	Sets the external input device connected to the microphone/cable release terminal.	Auto Select	p.53	
Auto Power Off	Sets the time until the camera turns off automatically if no operations are made for a certain period of time.	1min.	p.42		
4	Create New Folder	Creates a new folder on the memory card.	–	p.111	
	Folder Name	Sets the folder name in which images are stored.	Date	p.111	
	File Name	Sets the file name assigned to an image.	IMGP, _IMG	p.112	
	File No.	Sequential Numbering	Continues the sequential numbering for the file name when a new folder is created.	On	p.113
		Reset File Number	Resets the file number setting and returns to 0001 each time a new folder is created.	–	
	Copyright Information	Sets the photographer and copyright information embedded in the Exif data.	Off	p.113	
Format	Formats a memory card.	–	p.44		
5	Pixel Mapping	Maps out and corrects defective pixels on the sensor.	–	p.123	
	Dust Removal	Cleans the sensor by applying high-frequency (ultrasonic) vibrations.	On, On	p.123	
	Sensor Cleaning	Locks the mirror in the up position for cleaning the sensor with a blower.	–	p.124	
	Select Battery	Sets the battery priority for when using the optional battery grip.	Auto Select	p.39	
	Certification Marks	Displays the certification marks of conformance to wireless technical standards.	–	p.138	
	Firmware Info/Options	Displays the camera's firmware version. You can check the current firmware version before running an update.	–	–	
Reset	Resets the settings of the direct keys and Smart Function and for the items of the  menu,  menu,  menu,  menu, control panel, and playback mode palette.	–	–		

\*1 Available as a control panel item.

\*2 Available as a function of the function dial.

## Custom Setting Menus

1

Introduction

	Item	Function	Default Setting	Page
C1	<b>1 EV Steps</b>	Sets the adjustment steps for the exposure.	1/3 EV Steps	p.50
	<b>2 Sensitivity Steps</b>	Sets the adjustment steps for the ISO sensitivity.	1 EV Step	p.54
	<b>3 Meter Operating Time</b>	Sets the meter operating time.	10sec.	p.19
	<b>4 Auto EV Compensation</b>	Automatically compensates the exposure when the correct exposure cannot be achieved with the current settings.	Off	–
	<b>5 Link AE and AF Point</b>	Sets whether to link the exposure value and the AF point in the focusing area.	Off	p.57
	<b>6 AE-L with AF Locked</b>	Sets whether to lock the exposure value when the focus is locked.	Off	–
	<b>7 Bulb (B) Mode Options</b>	Sets the camera operation when <b>SHUTTER</b> is pressed in <b>B</b> mode.	Type1	p.51
C2	<b>8 Release While Charging</b>	Sets whether to release the shutter while the built-in flash is being charged.	Off	p.58
	<b>9 Bracketing Order</b>	Sets the order for Bracketing shooting.	0 - +	p.66
	<b>10 One-Push Bracketing</b>	Shoots all frames with one press of the release in Bracketing.	Off	p.66
	<b>11 Interval Shooting Options</b>	Sets whether to start counting the time of interval from when exposure starts or when exposure ends for Interval Shooting, Interval Composite, and Interval Movie Record.	Interval	p.71
	<b>12 AF in Interval Shooting</b>	Sets whether to lock the focus position used when the first picture is taken or perform autofocus for each exposure for Interval Shooting, Interval Composite, Interval Movie Record, and Star Stream.	Locks focus at 1st exposure	p.71
	<b>13 WB Adjustable Range</b>	Sets whether to automatically fine-tune the white balance when the light source is specified for the white balance setting.	Fixed	p.72
	<b>14 AWB in Tungsten Light</b>	Sets the tungsten light color tone when the white balance is set to [Auto White Balance].	Strong Correction	p.72

	Item	Function	Default Setting	Page
C3	<b>15 WB When Using Flash</b>	Sets the white balance setting when using a flash.	Auto White Balance	p.72
	<b>16 Color Temperature Steps</b>	Sets the adjustment steps for the Color Temperature option of the white balance.	Kelvin	p.73
	<b>17 Enable/Disable Control</b>	Temporarily disables specific functions or operations of buttons and dials.	Type1	p.51
	<b>18 4-way Controller Settings</b>	Selects the operation of the arrow keys (▲▼◀▶) when the focusing area selection mode is set to one of some select-type options.	Type1	p.61
	<b>19 Auto SR Off</b>	Automatically turns off the Shake Reduction function when the drive mode is set to [Self-timer].	Enable Auto SR Off	p.64
	<b>20 Save Rotation Info</b>	Saves rotation information when shooting.	On	p.84
	<b>21 Save Menu Location</b>	Saves the last menu tab displayed on the monitor and displays it again the next time <b>MENU</b> is pressed.	Reset Menu Location	p.23
C4	<b>22 Catch-in Focus</b>	Enables Catch-in Focus shooting when a manual focus lens is attached. The shutter is released automatically when the subject comes into focus.	Off	p.119
	<b>23 AF Fine Adjustment</b>	Allows you to precisely fine-tune your lenses with the camera's autofocus system.	Off	p.63
	<b>24 Using Aperture Ring</b>	Enables the shutter to release when the lens aperture ring is set to a position other than <b>A</b> (Auto).	Disable	p.118
	<b>Reset Custom Functions</b>	Resets the setting values of the Custom Setting menu items to the defaults.	–	–

## Attaching the Strap

- 1 Pass the end of the strap through the triangular ring.

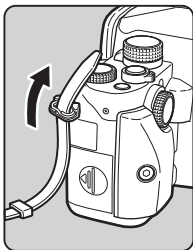

- 2 Secure the end of the strap on the inside of the clasp.

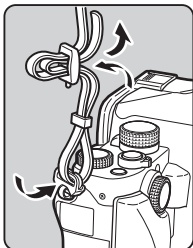

## Using the Optional Grip

The Grip S O-GP167 is installed on the camera. To replace it with the optional Grip M O-GP1671 or Grip L O-GP1672, fully loosen the grip mounting screw using the hex wrench supplied with the optional grip, and remove the grip. (The screw cannot be removed from the grip.)

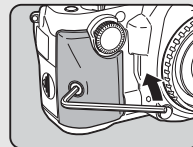

Attach the grip to the camera so that the tabs of the grip are engaged in the slots on the camera, and securely tighten the grip mounting screw.

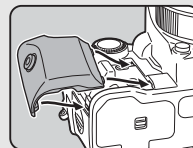

The optional Battery Grip D-BG7 is supplied with the Grip L O-GP1672.

## Attaching a Lens

**1** Make sure that the camera is turned off.

**2** Remove the body mount cap (①) and lens mount cover (②).

Turn the body mount cap counterclockwise while pressing the lens unlock button (③).

After removing the cover, be sure to put the lens down with the lens mount side facing upward.

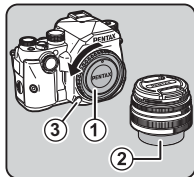

**3** Align the lens mount indexes (red dots: ④) on the camera and the lens, and secure by turning the lens clockwise until it clicks.

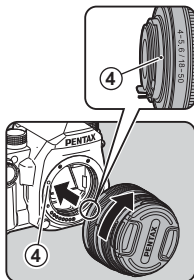

### To remove the lens

Attach the lens cap, and then turn the lens counterclockwise while pressing the lens unlock button.

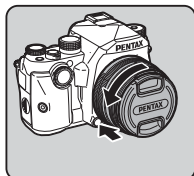

### ⚠ Caution

- When attaching or removing the lens, choose an environment that is relatively free of dirt and dust.
- Keep the body mount cap attached on the camera when a lens is not attached.
- Be sure to attach the lens mount cover and lens cap to the lens after removing it from the camera.
- Do not insert your fingers inside the lens mount of the camera or touch the mirror.
- The camera body and lens mount incorporate lens information contacts. Dirt, dust, or corrosion may damage the electrical system. Please contact your nearest service center for professional cleaning.
- When a retractable lens is attached and is not extended, you cannot take pictures or use some functions. If the lens is retracted during shooting, the camera stops working. Refer to “How to Use a Retractable Lens” (p.46) for details.
- We assume no responsibility nor liability for accidents, damages, and malfunctions resulting from the use of lenses made by other manufacturers.

### 📌 Memo

- Refer to “Functions Available with Various Lenses” (p.116) for details on the functions of each lens.

## Using the Battery and Charger

Use the battery D-LI109 and battery charger D-BC109 exclusively developed for this camera.

Note: AC plug cord

UL Listed, Type SPT-2 or NISPT-2, 18/2 flexible cord, rated 125 V, 7 A, minimum 6 ft. (1.8 m)

### Charging the Battery

- 1 **Connect the AC plug cord to the battery charger.**
- 2 **Plug the AC plug cord into the power outlet.**

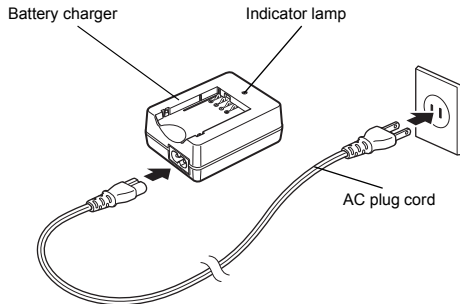

- 3 **Face the ▲ mark on the battery up, and insert it into the battery charger.**

Insert the battery into the battery charger at an angle, and then fit into place.

The indicator lamp lights while charging and turns off when the battery is fully charged.

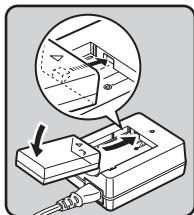

### ⚠ Caution

- Do not use the battery charger D-BC109 to charge batteries other than the battery D-LI109. Charging other batteries may cause damage or heating.
- Replace the battery with a new one in the following cases:
  - If the indicator lamp blinks or does not light after the battery is inserted correctly
  - If the battery starts to run down more quickly even after being charged (the battery may have reached the end of its service life)

### 📌 Memo

- The maximum charging time is approximately 240 minutes (it depends on temperature and remaining battery power). Charge the battery in a location where the temperature is between 0°C and 40°C (32°F and 104°F).



## Inserting/Removing the Battery

### ⚠ Caution

- Insert the battery correctly. If the battery is inserted incorrectly, it may not be removed.
- Wipe the electrodes of the battery with a soft dry cloth before inserting.
- Do not open the battery cover or remove the battery while the power is on.
- Be careful as the camera or battery may become hot after the camera has been used continuously for a long period of time.
- Remove the battery when you do not use the camera for a long time. The battery may leak and damage the camera if left installed during prolonged periods of non-use. If the removed battery is not used for six months or longer, charge the battery for about 30 minutes before storing it. Be sure to recharge the battery every six to twelve months.
- Store the battery in a location where the temperature will remain at or below room temperature. Avoid locations with high temperatures.
- The date and time may be reset if you leave the battery out of the camera for long periods of time. If this happens, set the current date and time again. (p.42)

### 1 Open the battery cover.

Slide the battery cover unlock lever (①) before opening the cover.

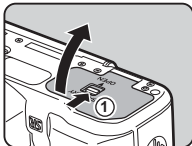

### 2 Face the ▲ mark on the battery towards the lens mount side of the camera, and insert the battery until it locks into place.

To remove the battery, push the battery lock lever in the direction of ②.

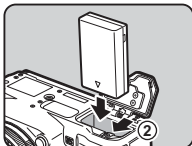

### 3 Close the battery cover.

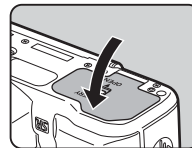

### 📌 Memo

- The battery level may not be displayed properly if the camera is used at low temperatures or when performing Continuous Shooting for a long time.
- Battery performance temporarily decreases as the temperature decreases. When using the camera in cold climates, have extra batteries at hand and keep them warm in your pocket. Battery performance will return to normal at room temperature.
- Have extra batteries ready when traveling overseas or taking a lot of pictures.
- When using the optional Battery Grip D-BG7, you can set priority of the battery to use in [Select Battery] of the  5 menu. (p.33)

## Using the AC Adapter

We recommend the use of the optional AC adapter kit K-AC167 when using the monitor for a long time or when connecting the camera to a computer.

**1** Make sure that the camera is turned off, and open the terminal cover.

**2** Align the ▲ marks on the DC terminal of the AC adapter and DC input terminal of the camera, and connect.

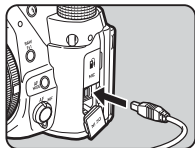

**3** Connect the AC adapter to the AC plug cord, and plug the cord into the power outlet.

### ⚠ Caution

- Make sure that the camera is turned off before connecting or disconnecting the AC adapter.
- Make sure that the connections are secure between the terminals. The memory card or data may be corrupted if the connection to the power supply is lost while the card is being accessed.
- Be sure to read the manual of the AC adapter kit before using the AC adapter.

## Inserting a Memory Card

The following memory cards can be used with this camera.

- SD Memory Card
- SDHC Memory Card
- SDXC Memory Card

In this manual, these cards are referred to as memory cards.

**1** Make sure that the camera is turned off.

**2** Slide the memory card cover in the direction of ① and then rotate it to open as shown by ②.

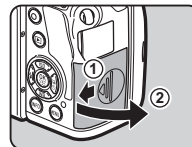

**3** Insert a card all the way into the memory card slot with the memory card label facing toward the side with the monitor.

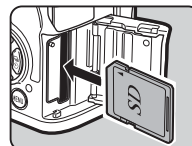

Push the memory card in once and release to remove.

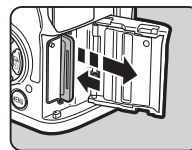

**4** Rotate the memory card cover as shown by ③, and slide it in the direction of ④.

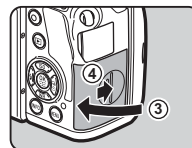

## ⚠ Caution

- Do not remove the memory card while the card access lamp (orange) is lit.
- If the memory card cover is opened while the power is on, the camera turns off. Do not open the cover while the camera is in use.
- Use this camera to format (initialize) a memory card that is unused or has been previously used on other devices. (p.44)
- Use a high-speed memory card when recording movies. If the write speed cannot keep up with the recording speed, writing may stop during recording.

## Adjusting the Angle of the Monitor

You can adjust the monitor angle in vertical direction.

- 1 Hold the camera grip with your right hand and hold the top of the monitor with your left hand.**

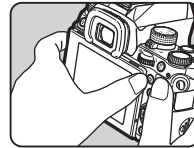

- 2 Slowly pull open the monitor until it stops.**

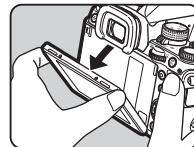

- 3 Hold the bottom of the monitor and lift upward.**

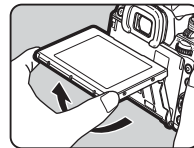

- 4 Adjust the angle.**

Perform Step 3 and then Step 2, towards directions opposite to the arrows, to retract the monitor.

## ⚠ Caution

- Do not twist or apply strong force to the movable section.
- Be careful not to hit the viewfinder part with the monitor.
- Keep the monitor retracted when carrying the camera.

## Initial Settings

Turn the camera on and make the initial settings.

### Turning the Camera On

#### 1 Turn the main switch to [ON].

The first time the camera is turned on after purchase, the [Language/言語] screen appears.

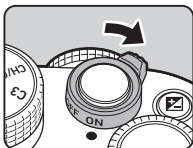

#### Memo

- The power automatically turns off when you do not perform any operations within a set period of time. (Default setting: 1min.) You can change the setting in [Auto Power Off] of the menu. (p.33)

### Setting the Display Language

#### 1 Use to select the desired language and press **OK**.

The [Initial Setting] screen appears in the selected language.

Proceed to Step 6 if (Hometown) does not need to be changed.

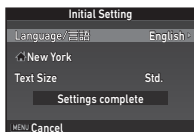

#### 2 Press to move the frame to and press .

The [ Hometown] screen appears.

#### 3 Use to select a city.

Use to change the region.

- Cities that can be selected as a hometown (p.131)

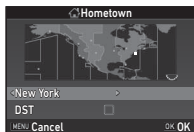

#### 4 Press to select [DST] (daylight saving time), and use to select or .

#### 5 Press **OK**.

The camera returns to the [Initial Setting] screen.

#### 6 Press to select [Text Size] and press .

#### 7 Use to select [Std.] or [Large], and press **OK**.

Selecting [Large] increases the text size of the selected menu item.

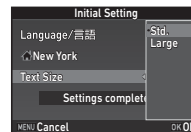

#### 8 Press to select [Settings complete] and press **OK**.

The [Date Adjustment] screen appears.

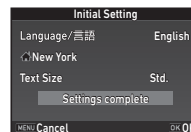

## Setting the Date and Time

- 1 Press **▶**, and use **▲▼** to select the date format.

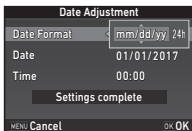

- 2 Press **▶**, and use **▲▼** to select [24h] or [12h].

- 3 Press **OK**.

The frame returns to [Date Format].

- 4 Press **▼**, and then press **▶**.

The frame moves to the month if the date format is set to [mm/dd/yy].

- 5 Use **▲▼** to set the month.

Set the day, year, and time in the same manner.

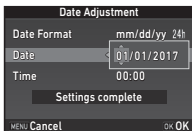

- 6 Press **▼** to select [Settings complete] and press **OK**.

The [LCD Display] screen appears.

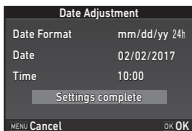

## Setting the LCD Display

- 1 Use **◀▶** to select a color.

Select the display color of the status screen, control panel, and menu cursor from the colors 1 to 12.

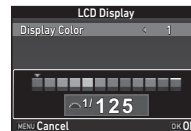

- 2 Press **OK**.

The camera switches to capture mode and is ready to take a picture.

### Memo

- You can change the language, text size, and date and time settings from the **1** menu, and the display color from [Other Display Settings] of the **5** menu. (p.27, p.32)

## Formatting a Memory Card



- 1 Press **MENU**.  
The 1 menu appears.
- 2 Use or to display the 4 menu.
- 3 Use or to select [Format] and press .  
The [Format] screen appears.
- 4 Press to select [Format] and press **OK**.  
Formatting starts. When formatting is completed, the 4 menu reappears.
- 5 Press **MENU**.

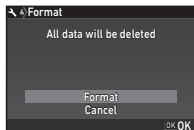

### ⚠ Caution

- Do not remove the memory card while formatting, or the card may be damaged.
- Formatting deletes all data, both protected and unprotected.

### 📝 Memo

- When a memory card is formatted, the volume label “KP” is assigned to the card. When the camera is connected to a computer, the memory card is recognized as a removable disk with the name “KP”.

## Basic Shooting Operation

Take pictures in **AUTO** (Scene Analyze Auto) mode in which the camera analyzes shooting conditions and automatically sets the optimal shooting settings.

### Shooting with the Viewfinder

- 1 Remove the front lens cap by pushing the top and bottom portions as indicated in the illustration.

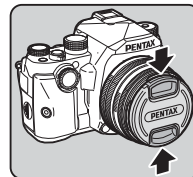

When a retractable lens is attached, extend the lens before turning the camera on.

How to Use a Retractable Lens (p.46)

- 2 Turn the camera on.
- 3 Set the /[LV]/ switch to .

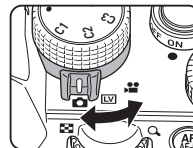

- 4 Set the **AF/MF** switch to **AF**.

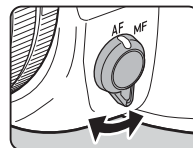

- 5** Set the mode dial to **AUTO** while pressing the mode dial lock button.

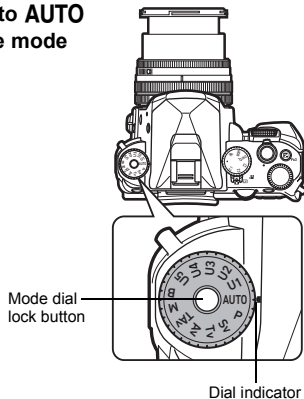

The selected capture mode and functions assigned to buttons/dials are displayed on the monitor (Guide Display).

- Guide Display settings (p.27)

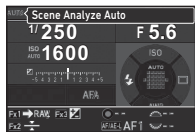

- 6** Look through the viewfinder to view the subject.

When using a zoom lens, turn the zoom ring to the right or left to change the angle of view.

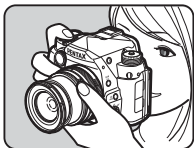

- 7** Position the subject inside the AF frame and press **SHUTTER** halfway.

The focus indicator (●) appears and you will hear a beep when the subject comes into focus.

- Sound Effects settings (p.32)



Focus indicator

- 8** Press **SHUTTER** fully.

The captured image is displayed on the monitor (Instant Review).

#### Available operations during Instant Review

	Deletes the image.
	Magnifies the image.
	Saves the RAW data (only when a JPEG image was taken and the data remains in the buffer).

#### Memo

- You can use **AF/AE-L** to focus on the subject. (p.59)
- You can select whether to make a beep sound and change the sound volume in [Sound Effects] of the **1** menu. (p.32)
- You can set the operation and display settings for Instant Review in [Instant Review] of the **5** menu. (p.26) When [Display Time] is set to [Hold], the Instant Review image is displayed until the next operation.

#### Caution

- Some functions are not available in **AUTO** mode.

### How to Use a Retractable Lens

If the camera is turned on when a retractable lens, such as smc PENTAX-DA L 18-50mm F4-5.6 DC WR RE, is attached and is not extended, an error message is displayed on the monitor. Turn the zoom ring in the direction of ② while pressing the button on the ring (①) to extend the lens. When retracting the lens, turn the zoom ring in the opposite direction to ② while pressing the button on the ring and align the white dot to the position ③.

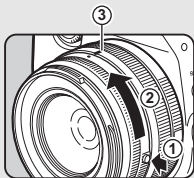

### Shooting while Viewing the Live View Image

- 1 Set the /LV/ switch to **LV** in Step 3 of “Shooting with the Viewfinder” (p.44).

The Live View image is displayed on the monitor.

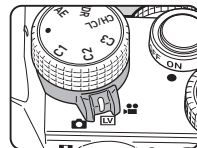

- 2 Position the subject inside the AF frame on the monitor and press **SHUTTER** halfway.

The AF frame turns green and you will hear a beep when the subject comes into focus.



AF frame

#### Available operations

- OK** Magnifies the image.  
Use to change the magnification (up to 16×).
- Use to change the area to display.  
Press to return the display area to the center.
- Press **OK** to return to 1× image display.

Subsequent steps are the same as shooting with the viewfinder.

#### Memo

- You can change the Live View display settings in [Live View] of the 5 menu. (p.26) When [Grid Display] is assigned to the function dial, you can change the setting using the Smart Function. (p.21, p.105)
- When [Image Magnification] is assigned to the function dial, you can magnify the image using the Smart Function in Step 2. (p.21, p.105)



## Reviewing Images

You can review the captured image on the monitor.

### 1 Press .

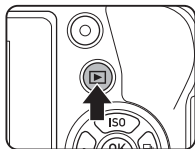













The camera enters playback mode and the most recently captured image is displayed (single image display).







### 2 Review the captured image.

#### Available operations

 to the left	Displays the previous image.
 to the right	Displays the next image.
	Deletes the image.
 to the right	Magnifies the image (up to 16×). Use    to change the area to display. Press  to return the display area to the center. Press  to return to entire image display mode.
 to the left	Switches to thumbnail display mode (p.82).
	Saves the RAW data (only when a JPEG image was taken and the data remains in the buffer).
	Changes the type of information displayed (p.17).
	Displays the playback mode palette (p.81).

#### Memo

- When  is turned to the right to magnify the image, the magnification is displayed at the bottom right of the screen. You can set the initial magnification when magnifying images in [Quick Zoom] of the 1 menu. (p.31)
- When  RAW is displayed on the monitor, the JPEG image that was just taken can also be saved in RAW format (Save RAW Data).
- You can display grid lines in single image display. Set in [Grid Display] of [LCD Display] in the 1 menu. (p.31)
- You can change the [Grid Display], [LCD Display Options], [Image Magnification], and [Outdoor View Setting] settings using the Smart Function during playback when these features are assigned to the function dial. (p.21, p.105)

## Configuring the Capture Settings

### Image Capture Settings



Set the file format for still pictures in [Image Capture Settings] of the 2 menu.

File Format	JPEG, RAW, RAW+
JPEG Recorded Pixels	<input type="checkbox"/> L, <input type="checkbox"/> M, <input type="checkbox"/> S, <input type="checkbox"/> XS
JPEG Quality	★★★, ★★, ★
RAW File Format	PEF, DNG
Color Space	sRGB, AdobeRGB

#### Memo

- When [File Format] is set to [RAW+], a JPEG image and a RAW image with the same file number are saved at the same time.
- [PEF] of [RAW File Format] is a PENTAX original RAW file format.
- When you press and hold (default setting), a beep sounds and you can temporarily take pictures in another file format (One Push File Format). (p.103)
- When [Recorded Pixels] is assigned to the function dial, you can change the number of recorded pixels for JPEG images or movies using the Smart Function. (p.21, p.105)

### Movie Capture Settings



Set the file format for movies in [Movie Capture Settings] of the 1 menu.

Recorded Pixels	Frame Rate
<input type="checkbox"/> FullHD	60i, 50i, 30p, 25p, 24p
<input type="checkbox"/> HD	60p, 50p

## Taking Still Pictures

Select the capture mode that suits the subject and shooting conditions.

The following capture modes are available on this camera.

Capture Mode	Function	Page
<b>AUTO</b> (Scene Analyze Auto mode)	Automatically sets the optimal shooting settings.	p.44
<b>P, Sv, Tv, Av, TAv, M, B</b> (Exposure modes)	Allows you to change the shutter speed, aperture value, and sensitivity.	p.49
<b>U1</b> (HDR LANDSCAPE)	Gives a bold and dramatic look to landscape shots.	-
<b>U2</b> (MACRO)	Automatically selects the optimal settings for macro shooting.	
<b>U3</b> (ASTROPHOTO)	Adjusts the background black level and reproduces the colors of stars faithfully.	
<b>U4</b> (MANUAL LENS)	Automatically selects the optimal settings for shooting with manual focus lenses.	

#### Memo

- You can save frequently used exposure modes and capture settings to **U1** to **U5** and replace the preset settings with them. (p.108)

## Shooting in Exposure Modes

✓: Available #: Restricted ✕: Not available

Mode	Change Shutter Speed	Change Aperture Value	Change Sensitivity	EV Compensation
<b>P</b> Program Automatic Exposure	# *1	# *1	✓	✓
<b>Sv</b> Sensitivity Priority Automatic Exposure	✕	✕	✓ *2	✓
<b>Tv</b> Shutter Priority Automatic Exposure	✓	✕	✓	✓
<b>Av</b> Aperture Priority Automatic Exposure	✕	✓	✓	✓
<b>TAv</b> Shutter & Aperture Priority Automatic Exposure	✓	✓	✕ *3	✓
<b>M</b> Manual Exposure	✓	✓	✓ *2	✓
<b>B</b> Bulb Exposure	✕ *4	✓	✓ *2	✕

\*1 You can set the value to change in [E-Dial Programming] of [Button Customization] in the 5 menu. (p.106)

\*2 [ISO AUTO] is not available.

\*3 Fixed to [ISO AUTO].

\*4 When the timed exposure is enabled, shutter speeds ranging from 10 seconds to 20 minutes can be set. (p.51)

### 1 Set the mode dial to the desired exposure mode.

or appears on the status screen for the value that can be changed.

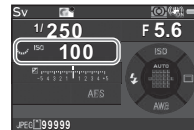

The value that can be changed is underlined in the viewfinder.

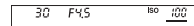

During Live View, appears for the value that can be changed.



### 2 Turn .

The aperture value is changed in **Av**, **TAv**, **M**, or **B** mode. The sensitivity is changed in **Sv** mode.

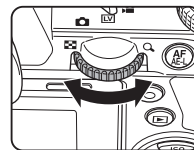

### 3 Turn .



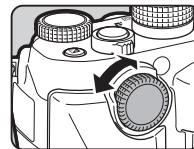

The shutter speed is changed in **Tv**, **TAv**, or **M** mode.



3

Shooting

### Memo

- The settings for the exposure can be specified in increments of 1/3 EV steps. In [1 EV Steps] of the **C1** menu, you can change the adjustment steps to 1/2 EV steps.
- In **M** mode, the difference from the correct exposure is displayed on the EV bar scale while the exposure is adjusted.
- For each exposure mode (excluding **B** mode), you can set the camera operation for when  or  is turned or  is pressed. Set in [E-Dial Programming] of [Button Customization] in the 5 menu. (p.106)
- In **Tv** or **Av** mode, you can take pictures while automatically changing shutter speed and aperture value. (p.67, p.68)

### Caution

- The correct exposure may not be obtained with the selected shutter speed and aperture value when the sensitivity is fixed at a certain sensitivity.







## Reducing Noise when Shooting with a Slow Shutter Speed

When shooting with a slow shutter speed, you can reduce image noise in [Slow Shutter Speed NR] of [Noise Reduction] in the 2 menu.



<b>Auto</b>	Applies Noise Reduction according to the shutter speed, sensitivity, and internal temperature of the camera.
<b>On</b>	Applies Noise Reduction when the shutter speed is slower than 1 second.
<b>Off</b>	Does not apply Noise Reduction at any shutter speed.

## Setting the Exposure Control Method

In [Program Line] of the 1 menu, you can specify how the exposure is controlled.

 <b>Auto</b>	Determines the appropriate settings.
 <b>Standard</b>	Sets to the basic program automatic exposure (all-around mode).
 <b>Hi-speed Priority</b>	Prioritizes high shutter speeds.
 <b>DOF Priority (Deep)</b>	Closes the aperture for a deep depth of field.
 <b>DOF Priority (Shallow)</b>	Opens the aperture for a shallow depth of field.
 <b>MTF Priority</b>	Sets the sharpest aperture of the attached lens when a DA, DA L, D FA, FA J, or FA lens is used.

### Memo

- The Program Line setting is enabled in the following situations.
  - In **P** or **Sv** mode
  - When **PLINE** is set for the  operation of **TAv** or **M** in [E-Dial Programming] of [Button Customization] in the 5 menu
- When [Program Line] is assigned to the function dial, you can change the setting using the Smart Function. (p.21, p.105)

## Checking the Depth of Field (Preview)



When [Preview] is assigned to **Fx1**, **Fx2**, or **Fx3**, you can check the depth of field before taking pictures. (p.104)

## Locking the Exposure

To lock the exposure before shooting, use the AE Lock function. This function can be used by assigning [AE Lock] to **Fx1**, **Fx2**, **Fx3**, or **AF/AE-L**. (p.102)

## Disabling Operation Controls

Specific functions or operations of buttons and dials can be temporarily disabled to prevent misoperation during shooting by assigning [Operation Control Lock] to **Fx1**, **Fx2**, or **Fx3**. (p.102)

Turning  while pressing the button in standby mode disables the functions or operations of the buttons and dials. Turning  again enables the functions or operations of them.

 is displayed on the status screen and Live View screen while the functions or operations of the buttons and dials are disabled.

The functions or operations of buttons and dials to be disabled can be selected in [17 Enable/Disable Control] of the **C3** menu.





<b>Type1</b>	Disables the functions or operations of the buttons and dials used to change the exposure settings in standby mode.
<b>Type2</b>	Disables the functions or operations of <b>▲▼◀▶</b> , <b>OK</b> , and <b>MENU</b> in standby mode.

## Bulb Exposure

**1** Set the mode dial to **B**.

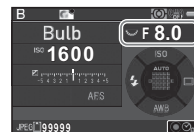
**2** Use  to set the aperture value.



**3** To enable the timed exposure, press , and then use  to set the exposure time.

You can set the exposure time within the range from 10" to 20'00".

**4** Press **SHUTTER**.

While **SHUTTER** is pressed, exposure continues.

If the timed exposure is enabled in Step 3, the exposure ends when the set exposure time elapses after **SHUTTER** is fully pressed.

### Memo

- You can start and end exposure also by pressing **SHUTTER**. Set in [7 Bulb (B) Mode Options] of the **C1** menu.
- When performing the bulb exposure, use a tripod and mount the camera on it securely. The use of the optional cable release is recommended. (p.53)

### Caution

- The drive mode cannot be set to [Continuous Shooting], [Bracketing], or [Interval Shooting].

## Using the Electronic Shutter

A mechanical shutter has front and rear shutter curtains, which make noise and vibrate the camera when opening and closing to produce the exposure.

Use of an electronic shutter can reduce noise and vibrations during exposure, and furthermore, enables shooting with faster shutter speeds than a mechanical shutter.

To use only the electronic shutter of the camera, select [Electronic Shutter] in [Shutter Mode Selection] of the 2 menu.

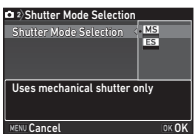

### Caution

- [Electronic Shutter] cannot be selected in the following situations.
  - In **B** mode
  - When the drive mode is set to [Interval Shooting]
- The following functions are not available when [Electronic Shutter] is selected.
  - Flash discharge
  - Shake Reduction
- Distortion can be produced in captured images when shooting fast moving objects with fast shutter speeds using the electronic shutter.

### Memo

- Shooting with Live View when the electronic shutter is selected (p.46) can deliver quieter shooting with less mirror movement sound.
- When [Shutter Mode Selection] is assigned to the function dial, you can change the setting using the Smart Function. (p.21, p.105)

## Recording Movies

1 Set the /[LV]/ switch to .

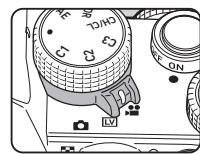

The Live View image is displayed.



2 Set the mode dial to the desired capture mode.

The following settings are available depending on the capture mode.

<b>P, Tv, Av, TvAv, M</b>	The camera operates in the selected exposure mode. (When set to <b>M</b> mode, the sensitivity can be changed.)
<b>U1 to U5</b>	The camera operates according to the saved exposure mode.
<b>Other modes</b>	The camera operates in <b>P</b> mode.

3 Use  or  to set the exposure.

4 Focus on the subject.

In **AF** mode, press **SHUTTER** halfway.

5 Press **SHUTTER** fully.

Movie recording starts. In the upper left area of the monitor, "REC" blinks and the size of the recorded movie file is displayed.

## 6 Press **SHUTTER** fully again.

Movie recording stops.

### ⚠ Caution

- When recording a movie with sound, camera operation sounds are also recorded. When [AF Mode] of [AF with Live View] in the 1 menu is set to **A.F.C.**, the focus operation sounds are recorded. Adjusting the sound volume in [Recording Sound Level] of the 1 menu, or using an external microphone can reduce the operation sounds to be recorded. When [Recording Sound Level] is set to [Manual], the sound volume can be set from 0 to 20.
- When recording a movie with an image processing function such as Digital Filter applied, the movie file may be saved with some frames omitted.
- If the internal temperature of the camera becomes high during recording, recording may be terminated.
- When a retractable lens is attached, recording stops if the lens is retracted during recording and an error message is displayed.

### 📝 Memo

- You can record a movie continuously up to 4 GB or approximately 25 minutes. When the memory card is full, recording stops.
- You can change the settings for movie recording in the menus. (p.29)
- By default, autofocus is not performed when **SHUTTER** is pressed halfway during movie recording. If a compatible lens is attached to the camera, you can select **A.F.C.** in [AF Mode] of [AF with Live View] in the 1 menu and continuously autofocus even during movie recording. (p.62) When [AF Mode] is set to **A.F.C.**, the **AF/AE-L** button operation varies as follows depending on the setting assigned to **AF/AE-L** in [Button Customization] of the 2 menu. (p.102)

[Button Customization] setting	Autofocus operation when <b>AF/AE-L</b> is pressed
<b>Enable AF1, Enable AF2</b>	Pressing <b>AF/AE-L</b> performs autofocus based on the [AF Mode] setting.
<b>Cancel AF</b>	Pressing <b>AF/AE-L</b> stops autofocus and pressing <b>AF/AE-L</b> again restarts autofocus.

## Using a Microphone or Cable Release

You can connect a commercially available stereo microphone to the microphone/cable release terminal on the camera. Using an external microphone can also help to reduce the possibility of recording camera operation sounds.

The following specifications are recommended for external microphones. (A monaural microphone cannot be used with this camera.)

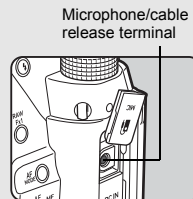

<b>Plug</b>	Stereo mini plug (ø3.5 mm)
<b>Format</b>	Stereo electret condenser
<b>Power</b>	Plug-in Power Method (operating voltage of 2.0 V or lower)
<b>Impedance</b>	2.2 kΩ

You can also connect the optional Cable Switch CS-310 to the microphone/cable release terminal on the camera. When the cable release is connected, sounds are recorded with the built-in microphone.

You can set the device to connect in [External Input Devices] of the 3 menu. Normally, you do not need to change the default setting ([Auto Select]).

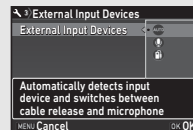

### ⚠ Caution

- Do not connect a microphone or other device outside the recommended specifications to the microphone/cable release terminal. Also, do not use an external microphone with a 3-meter or longer cable. Doing so may cause the camera to malfunction.
- If an external microphone is used when recording a movie with the Wi-Fi™ function enabled, radio noise may be recorded depending on the compatibility with the microphone.

## Playing Back Movies

- 1 Display the movie to play back in single image display of the playback mode.



### Available operations

▲	Plays back/pauses a movie.
▶	Forwards a frame (when paused).
Press and hold ▶	Fast-forwards playback.
◀	Reverses a frame (when paused).
Press and hold ◀	Fast-reverses playback.
▼	Stops playback.
	Adjusts the sound volume (21 levels).
<b>Fx3</b>	Saves the displayed frame as a JPEG file (when paused).
<b>INFO</b>	Switches between [Standard Information Display] and [No Information Display].

### Memo

- The sound volume at the start of movie playback can be set in [Playback Sound Volume] of the 1 menu. (p.31)
- In [Movie Edit] of the playback mode palette, a movie file can be divided into multiple segments or selected frames can be deleted. (p.89)

## Setting the Exposure

### Sensitivity

- 1 Press **▲** in standby mode.  
The sensitivity setting screen appears.  
In **Sv**, **TAv**, **M**, or **B** mode, proceed to Step3.
- 2 Use **▲▼** to select [ISO AUTO] or [ISO].



- 3 Use or to change the value.

<b>ISO AUTO</b>	Sets the upper limit and lower limit.
<b>ISO</b>	Selects a sensitivity value from ISO 100 to ISO 819200.



- 4 Press **OK**.  
The camera returns to standby mode.

### Memo

- The adjustment steps for ISO sensitivity is 1 EV step. To adjust the sensitivity in accordance with the EV step setting for the exposure, set from [2 Sensitivity Steps] of the **C1** menu.
- When the sensitivity is set to ISO 102400 or higher, ISO value is displayed in the viewfinder by a combination of the letter "H" and a three-digit number (e.g., ISO 102400 = H102).



## Changing the Sensitivity in Standby mode

When [Sensitivity] is assigned to **Fx1**, **Fx2**, or **Fx3**, you can change the sensitivity by turning  while pressing the button. (p.102)  
Press  to reset the sensitivity to [ISO AUTO].

When [Sensitivity] is assigned to the function dial, you can change the sensitivity using the Smart Function. (p.21, p.105) Select [ISO AUTO] in Step 2 to reset the sensitivity to [ISO AUTO].

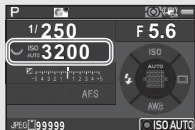

## Setting the Range of ISO AUTO



You can set the range in which the sensitivity is automatically adjusted for ISO AUTO in [ISO AUTO Setting] of the  menu.

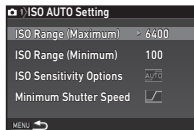



<b>ISO Range (Maximum)</b>	Sets the upper limit value for ISO AUTO.
<b>ISO Range (Minimum)</b>	Sets the lower limit value for ISO AUTO.
<b>ISO Sensitivity Options</b>	Sets whether to set the minimum shutter speed automatically (AUTO) or manually (Tv).
<b>Minimum Shutter Speed</b>	When [ISO Sensitivity Options] is set to [AUTO]: Slow, Std., Fast When [ISO Sensitivity Options] is set to [Tv]: 1/6000 to 30"

## Reducing Noise when Shooting with a High ISO Sensitivity



You can use the Noise Reduction feature when shooting with a high ISO sensitivity.

- 1 Select **[Noise Reduction]** in the  menu and press .
- The [Noise Reduction] screen appears.
- 2 Select **[High-ISO NR]** and press .
- 3 Select the Noise Reduction level and press **[OK]**.

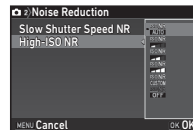

<b>Auto</b>	Applies Noise Reduction at optimally calculated levels throughout ISO range.
<b>Low, Medium, High</b>	Applies Noise Reduction at constant chosen level throughout ISO range.
<b>Custom</b>	Applies Noise Reduction at user-defined levels for each ISO setting.
<b>Off</b>	Does not apply Noise Reduction at any ISO setting.



Proceed to Step 7 when other than [Custom] is selected.

- 4 Select **[Setting]** and press .

- 5 Use **▲▼** to select a sensitivity and **◀▶** to select a Noise Reduction level.



#### Available operations

-  Shows the next/previous page.
-  Resets the Noise Reduction level to the default setting.

- 6 Press **MENU**.  
The screen of Step 3 reappears.

- 7 Press **MENU** twice.

## EV Compensation

The compensation value can be set between -5 and +5 EV (-2 and +2 EV in  mode).

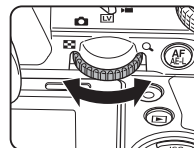
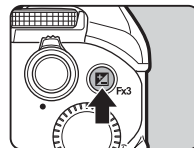

- 1 Press , and then turn .

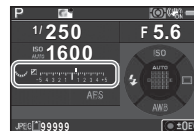

 and the compensation value are displayed on the status screen, Live View screen, and in the viewfinder during adjustment.



#### Available operations

-  Starts/ends adjusting the compensation value.
-  Resets the adjustment value to the default setting.

#### Memo

- Bracketing shooting enables you to take pictures while automatically changing the exposure. (p.66)
- You can assign other functions to  (**Fn3**). Also, you can assign [EV Compensation] to **Fx1** or **Fx2**. (p.102) When [EV Compensation] is assigned to the function dial, you can change the setting using the Smart Function. (p.21, p.105)



Choose the part of the sensor to use for measuring brightness and determining the exposure in [AE Metering] of the 1 and 1 menus.

<b>Multi-segment</b>	Meters the brightness in multiple different zones of the sensor. In backlit conditions, this mode automatically adjusts the exposure.
<b>Center-weighted</b>	Meters the brightness with an emphasis on the center of the sensor. The sensitivity increases at the center and no automatic adjustment is performed even in backlit conditions.
<b>Spot</b>	Meters the brightness only within a limited area at the center of the sensor. Useful when the subject is small. No automatic adjustment is performed even in backlit conditions.

### Memo

- In [5 Link AE and AF Point] of the **C1** menu, the metering point and the AF point can be linked.
- The metering method can also be set using the Smart Function. (p.21)

# Using the Built-in Flash

- 1 Press in standby mode.
- 2 Select a flash mode.



<b>Auto Flash Discharge</b>	Automatically measures the ambient light and determines whether to use the flash.
<b>Auto Flash + Red-eye</b>	Discharges a pre-flash for red-eye reduction before an automatic flash.
<b>Flash On</b>	Discharges a flash for each picture.
<b>Flash On + Red-eye</b>	Discharges a pre-flash for red-eye reduction before the main flash for each picture.
<b>Slow-speed Sync</b>	Sets to a slow shutter speed and discharges a flash for each picture. Use this, for example, when shooting a portrait with the sunset in the background.
<b>Slow Sync + Red-eye</b>	Discharges a pre-flash for red-eye reduction before the main flash is discharged with Slow-speed Sync.
<b>Trailing Curtain Sync</b>	Discharges a flash immediately before closing the shutter. Sets to a slow shutter speed. Captures moving objects as if they are leaving a light trail behind them.
<b>Manual Flash Discharge</b>	Sets the amount of flash discharge between FULL and 1/128 power.
<b>Wireless (Controller)</b>	Synchronizes with the dedicated external flash without using a sync cord. (p.120)

## Available operations



Compensates the flash exposure.  
Selects the amount of flash discharge (when [Manual Flash Discharge] is selected).



Resets the compensation value to the default setting.

3 Press **OK**.

The camera returns to standby mode.

4 Press **⏏**.

The built-in flash is popped up.

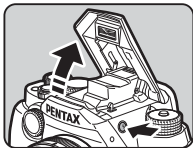

## Memo

- The flash modes that can be selected vary depending on the capture mode.

Capture Mode	Selectable Flash Mode
<b>AUTO</b>	⚡ <sup>A</sup> , ⚡ <sub>∞</sub> , ⚡ <sub>↓</sub> , ⚡ <sub>∞</sub>
<b>P, Sv, Av</b>	⚡ <sub>∞</sub> , ⚡ <sub>↓</sub> , <sup>SLW</sup> ⚡ <sub>∞</sub> , <sup>SLW</sup> ⚡ <sub>↓</sub> , <sup>SLW</sup> ⚡ <sub>∞</sub> , <sup>SLW</sup> ⚡ <sub>↓</sub> , ⚡ <sub>M</sub> , <sup>WZ</sup> ⚡ <sub>control</sub>
<b>Tv, TvAv, M, B</b>	⚡ <sub>∞</sub> , ⚡ <sub>↓</sub> , ⚡ <sub>∞</sub> , ⚡ <sub>↓</sub> , ⚡ <sub>M</sub> , <sup>WZ</sup> ⚡ <sub>control</sub>

- You cannot take pictures while the built-in flash is being charged. If you want to take pictures while charging the flash, set [8 Release While Charging] in the **C2** menu.
- Depending on the lens being used, the use of the built-in flash may be limited. (p.117)
- When the built-in flash is used in **Av** mode, the shutter speed automatically changes over a range from 1/180 seconds to a slow shutter speed depending on the lens being used. The shutter speed is locked at 1/180 seconds when a lens other than a DA, DA L, D FA, FA J, FA, or F lens is used.
- When the built-in flash is used in **Tv**, **TvAv**, or **M** mode, any desired shutter speed of 1/180 seconds or slower can be set.

- The built-in flash is optimum for a subject at a distance from approx. 0.7 m to 5 m. Vignetting may occur when used at a distance closer than 0.7 m (this distance varies slightly depending on the lens being used and the sensitivity setting).
- For details on the use of external flashes, refer to “Functions when Using an External Flash” (p.120).

## Guide Number

Sensitivity	Guide Number	Sensitivity	Guide Number
ISO 100	Approx. 6	ISO 12800	Approx. 68
ISO 200	Approx. 8.5	ISO 25600	Approx. 96
ISO 400	Approx. 12	ISO 51200	Approx. 136
ISO 800	Approx. 17	ISO 102400	Approx. 192
ISO 1600	Approx. 24	ISO 204800	Approx. 272
ISO 3200	Approx. 34	ISO 409600	Approx. 384
ISO 6400	Approx. 48	ISO 819200	Approx. 544

## Setting the Focus Method

Set the focus method using the **AF/MF** switch.

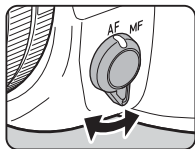

The autofocus method for shooting with the viewfinder differs from that for shooting with Live View.

<b>Shooting with the viewfinder</b>	TTL phase-matching AF: Select from <b>A.F.S.</b> , <b>A.F.C.</b> , or <b>A.F.A.</b> mode which enables automatically switching between <b>A.F.S.</b> and <b>A.F.C.</b> Faster autofocus performance than the contrast detection AF is possible. (p.59)
<b>Shooting with Live View</b>	Contrast detection AF: Face Detection and Tracking are available. (p.61)

### Focusing on the Subject Using the **AF/AE-L** Button

You can use **AF/AE-L** to focus on the subject. The **AF/AE-L** button operation can be set in [Button Customization] of the **☑5** and **☑2** menus. (p.102)

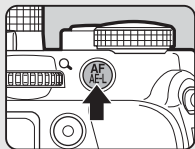

## Setting the Autofocus when Shooting with the Viewfinder



The autofocus operation when shooting with the viewfinder can be set in [AF with Viewfinder] of the **☑1** menu.

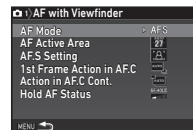

AF Mode	A.F.A., A.F.S., A.F.C
<b>AF Active Area</b>	Auto (27 AF Points), Zone Select, Select, Expanded Area AF (S), Expanded Area AF (M), Expanded Area AF (L), Spot
<b>A.F.S. Setting</b>	Focus-priority, Release-priority
<b>1st Frame Action in A.F.C</b>	Auto, Focus-priority, Release-priority
<b>Action in A.F.C Cont.</b>	Auto, Focus-priority, FPS-priority
<b>Hold AF Status</b>	Off, Low, Medium, High

### Memo

- The [AF Mode] and [AF Active Area] settings can be changed by turning or while pressing **AF/AE-L**. (p.60)
- When [AF Mode] or [AF Active Area] is assigned to the function dial, you can change the setting using the Smart Function. (p.21, p.105)
- In [Hold AF Status], you can set whether to immediately reactivate autofocus or to maintain the focus for a certain amount of time before reactivating autofocus when the subject happens to move out of the selected focusing area after being focused.

## AF Mode

- 1 Turn  while pressing .

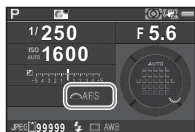
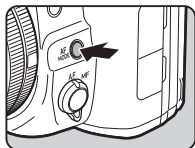

<b>AFA</b> (Auto-select mode)	Switches automatically between <b>AFS</b> and <b>AFC</b> modes according to the subject.
<b>AFS</b> (Single mode)	When <b>SHUTTER</b> is pressed halfway and the subject comes into focus, the focus is locked at that position. The AF assist light turns on as necessary.
<b>AFC</b> (Continuous mode)	The subject is kept in focus by continuous adjustment while <b>SHUTTER</b> is pressed halfway. The shutter can be released even if the subject is not in focus.





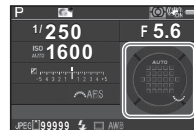

 **Memo**

- In **AUTO** mode, the autofocus mode is fixed to **AFA**.

## AF Active Area (AF Point)

- 1 Turn  while pressing .



 <b>Auto (27 AF Points)</b>	Out of the 27 AF points, the camera automatically selects the optimum focusing area.
 <b>Zone Select</b>	Out of the selected 9 AF points, the camera automatically selects the optimum focusing area.
 <b>Select</b>	Sets the focusing area to the user selected point from 27 points.
 <b>Expanded Area AF (S)</b>	Sets the focusing area to the user selected point from 27 points. When the subject happens to move out of the selected focusing area after being focused, 8 peripheral points are used as back-up points. Available only in <b>AFC</b> mode.
 <b>Expanded Area AF (M)</b>	Sets the focusing area to the user selected point from 27 points. When the subject happens to move out of the selected focusing area after being focused, 24 peripheral points are used as back-up points. Available only in <b>AFC</b> mode.
 <b>Expanded Area AF (L)</b>	Sets the focusing area to the user selected point from 27 points. When the subject happens to move out of the selected focusing area after being focused, 26 peripheral points are used as back-up points. Available only in <b>AFC</b> mode.
 <b>Spot</b>	Sets the focusing area to the center of the 27 points.

Proceed to Step 2 when other than [Auto (27 AF Points)] or [Spot] is selected.

## 2 Select the desired AF point.

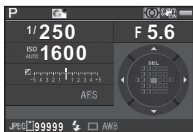

### Available operations



Changes the AF point.



Returns the AF point to the center.

Press and hold **OK**

Switches the function of the arrow keys (▲▼◀▶) to AF point change mode or direct key operation mode.

### Memo

- In **AUTO** mode, [AF Active Area] is fixed to [Auto (27 AF Points)].
- The [AF Mode] and [AF Active Area] settings can be checked also in the viewfinder. **AF** is displayed in the viewfinder when the AF point can be changed. (p.19)
- You can switch the function of the arrow keys to AF point change mode with **Fx1**, **Fx2**, or **Fx3**, instead of pressing and holding **OK**. (p.102) When [Change AF Area] is assigned to **Fx1**, **Fx2**, or **Fx3**, the operation by pressing and holding **OK** is disabled.
- You can select the button operation when changing the AF point in [18 4-way Controller Settings] of the **C3** menu.

<b>Type1</b>	Switches the function of the arrow keys alternately between AF point change mode and direct key operation mode.
<b>Type2</b>	Prioritizes the AF point change mode in standby mode.

## Setting the Autofocus when Shooting with Live View



The autofocus operation when shooting with Live View can be set in [AF with Live View] of the **1** and **1** menus.

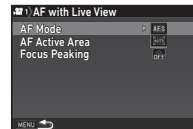
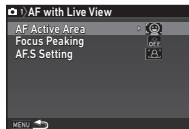

AF Mode	AF.S, A.F.C
<b>AF Active Area</b>	Face Detection, Tracking, Multiple AF Points, Select, Spot
<b>Focus Peaking</b>	Highlight Edge, Extract Edge, Off
<b>AF.S Setting</b>	Focus-priority, Release-priority

### Memo

- The [AF Mode] and [AF Active Area] settings can be changed by turning or while pressing **MODE**. (p.62)
- When [AF Mode], [AF Active Area], or [Focus Peaking] is assigned to the function dial, you can change the setting using the Smart Function. (p.21, p.105)
- When [Focus Peaking] is set to [Highlight Edge] or [Extract Edge], the outline and contrast of the subject in focus is emphasized, and this makes it easier to check the focus. This function works in both **AF** and **MF** modes. The outline of the subject is not emphasized while autofocus is performed or a movie is recorded. Histogram Display and Highlight Alert become inactive while the outline of the subject is emphasized.

## AF Mode

When a compatible lens is attached and the camera is in  mode, the menu item [AF Mode] becomes available and the autofocus mode can be changed.

- 1 Turn  while pressing .

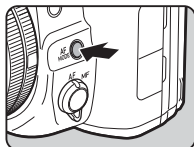





### Memo

- Update the camera and lens firmware to the latest version in order to make the menu item [AF Mode] available. For more information on the firmware update, visit [http://www.ricoh-imaging.co.jp/english/support/download\\_digital.html](http://www.ricoh-imaging.co.jp/english/support/download_digital.html)

## AF Active Area

- 1 Turn  while pressing .



 <b>Face Detection</b>	Detects and tracks faces of people. The main face detection frame for AF and AE is displayed in yellow.
 <b>Tracking</b>	Tracks the subject in focus. The shutter can be released even if the subject is not in focus.
 <b>Multiple AF Points</b>	Sets the focusing area to the desired area. The sensor is divided into 35 areas (7 horizontal by 5 vertical), and you can select a wider or narrower focusing area by using 1, 9, 15, 25, or 35 of those 35 available areas.
 <b>Select</b>	Sets the focusing area by the pixel.
 <b>Spot</b>	Sets the focusing area to a limited area at the center.

Select from [Multiple AF Points], [Select], or [Spot] in  mode.

Proceed to Step 2 when [Multiple AF Points] or [Select] is selected.

- 2 Press and hold .



### 3 Select the AF area.

Use the frame that appears on the monitor to change the position and size of the AF area.



#### Available operations

▲▼◀▶ Changes the position of the AF area.



Increases/reduces the size of the AF area (when [Multiple AF Points] is selected).



Returns the AF area to the center.

### 4 Press **OK**.

The AF area is set.

#### Memo

- In **AUTO** mode, [AF Active Area] is fixed to [Face Detection].
- You can switch the function of the arrow keys to AF area change mode with **Fx1**, **Fx2**, or **Fx3**, instead of pressing and holding **OK**. (p.102) When [Change AF Area] is assigned to **Fx1**, **Fx2**, or **Fx3**, the operation by pressing and holding **OK** is disabled.

## AF Fine Adjustment

**C4**

You can precisely fine-tune your lenses with the camera's autofocus system.

### 1 Select [23 AF Fine Adjustment] in the **C4** menu and press **▶**.

The [23 AF Fine Adjustment] screen appears.

### 2 Select [Apply All] or [Apply One] and press **OK**.

Apply All	Applies the same adjustment value to all lenses.
Apply One	Saves an adjustment value for the lens being used. (Up to 20 values)

### 3 Select [Setting] and adjust the value.

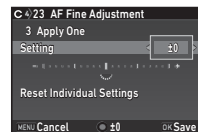

#### Available operations

▶/👤 to the right Adjusts the focus to a closer position.

◀/👤 to the left Adjusts the focus to a farther position.

○ Resets the adjustment value to the default setting.

### 4 Press **OK**.

The adjustment value is saved.

### 5 Press **MENU** twice.

The camera returns to standby mode.

## Setting the Drive Mode

### 1 Press **▶** in standby mode.

The Drive Mode screen appears.

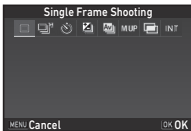

### 2 Select a drive mode.

<b>Single Frame Shooting</b> (□)	Normal capture mode
<b>Continuous Shooting</b> (□, □, □)	Continuously takes pictures while <b>SHUTTER</b> is kept pressed. (p.65)
<b>Self-timer</b> (☺, ☺, ☺)	Releases the shutter about 12 seconds or 2 seconds after <b>SHUTTER</b> is pressed. (p.65)
<b>Bracketing</b> ([A], [A])	Takes consecutive pictures at different exposure levels. (p.66)
<b>Depth of Field Bracketing</b> ([A], [A])	Takes consecutive pictures at different depth of fields (aperture values). (p.67)
<b>Motion Bracketing</b> ([T], [T])	Takes consecutive pictures at different shutter speeds. (p.68)
<b>Mirror Lock-up Shooting (MUP)</b>	Takes pictures with the mirror raised. (p.69)
<b>Multi-exposure</b> ([M], [M], [M])	Creates a composite image by taking multiple pictures and merging them into a single image. (p.69)
<b>Interval Shooting</b> ([INT], [INT], [INT], [INT])	Automatically takes pictures at set intervals. (p.70)

### ⚠ Caution

- There are restrictions on some drive modes when used in combination with some other functions. (p.115)

### 📌 Memo

- The Drive Mode setting is saved even after the power is turned off. If [Drive Mode] is set to □ (Off) in [Memory] of the 📷5 menu, the setting returns to [Single Frame Shooting] when the power is turned off. (p.110)
- When a drive mode that employs the self-timer is selected, [Shake Reduction] of the 📷4 menu is automatically set to [Off]. If you do not want to turn off the Shake Reduction function, set in [19 Auto SR Off] of the 📷3 menu.



### If Light Enters through the Viewfinder

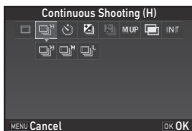

When a drive mode that employs the self-timer is selected, exposure may be affected by the light entering through the viewfinder. In such a case, use the AE Lock function. (p.51)

## Continuous Shooting

- 1 Select  on the Drive Mode screen and press **▼**.



- 2 Use **◀▶** to select , , or , and press **OK**.

	Continuous Shooting (at high speed)
	Continuous Shooting (at medium speed)
	Continuous Shooting (at low speed)

The camera returns to standby mode.

### Memo



- You can change the shooting speed for Continuous Shooting using the Smart Function. (p.21)
- When [AF Mode] in [AF with Viewfinder] of the 1 menu is set to **A.F.S.**, the focus position is locked in the first frame. (p.60)

## Self-timer

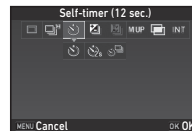
- 1 Select  on the Drive Mode screen and press **▼**.



- 2 Use **◀▶** to select , , or .

	Self-timer (shutter release after about 12 seconds)
	Self-timer (shutter release after about 2 seconds)
	Self-timer + Continuous Shooting

Proceed to Step 6 when  or  is selected.

- 3 Press **INFO**.

- 4 Set [Shooting Speed] and [Number of Shots].

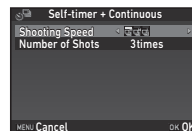

- 5 Press **OK**.  
The screen of Step 1 reappears.

- 6 Press **OK**.  
The camera returns to standby mode.

- 7 Press **SHUTTER** halfway, and then fully.  
The shutter is released after about 12 seconds or 2 seconds.



## Bracketing

You can take multiple images at different exposure levels.

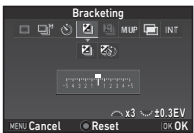
**1** Select  on the Drive Mode screen and press **▼**.



**2** Use **◀▶** to select  or .

	Bracketing
	Bracketing + Self-timer

Proceed to Step 6 when  is selected.

**3** Press **INFO**.

**4** Select a self-timer mode.







**5** Press **OK**.

The screen of Step 1 reappears.

**6** Set the number of shots and bracket value.

### Available operations

-  Sets the number of shots.
-  Changes the bracket value.
-  Adjusts the exposure compensation value.
-  Resets the adjustment value to the default setting.

**7** Press **OK**.

The camera returns to standby mode.

**8** Shoot.

After pictures are taken, the camera returns to standby mode.

### Memo

- The bracket value can be set in increments of 1/3 EV steps or 1/2 EV steps according to the [1 EV Steps] setting of the **C1** menu.
- The following settings for Bracketing can be set in the **C2** menu.

<b>9 Bracketing Order</b>	Changes the shooting order of pictures.
<b>10 One-Push Bracketing</b>	Takes all pictures with one release of the shutter.

- When [Bracket Value] is assigned to the function dial, you can change the bracket value using the Smart Function. (p.21, p.105)



## Depth of Field Bracketing

You can take three consecutive images at different aperture values without changing the exposure.  
This function is only available in **Av** mode.

- 1 Select  on the Drive Mode screen and press **▼**.



- 2 Use **◀▶** to select  or .

	Bracketing
	Bracketing + Self-timer

Proceed to Step 6 when  is selected.

- 3 Press **INFO**.

- 4 Select a self-timer mode.

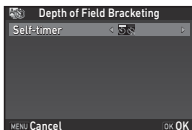



- 5 Press **OK**.

The screen of Step 1 reappears.

- 6 Use  to set the bracketing order and bracket value.

### Available operations

 to the right Takes pictures using smaller apertures (larger f-numbers) than the current setting.

 to the left Takes pictures using larger apertures (smaller f-numbers) than the current setting.

 Resets the adjustment value to the default setting.

- 7 Press **OK**.

The camera returns to standby mode.

- 8 Shoot.

Takes three pictures with one release of the shutter.  
The camera returns to standby mode.

### Memo

- The bracket value can be set in increments of 1/3 EV steps or 1/2 EV steps according to the [1 EV Steps] setting of the **C**1 menu.

### Caution

- When using a lens with an **A** position, if the aperture ring is set to a position other than **A**, [Depth of Field Bracketing] cannot be selected.

## Motion Bracketing

You can take three consecutive images at different shutter speeds without changing the exposure. This function is only available in **Tv** mode.

**1** Select on the Drive Mode screen and press **▼**.



**2** Use **◀▶** to select or .

	Bracketing
	Bracketing + Self-timer

Proceed to Step 6 when is selected.

**3** Press **INFO**.

**4** Select a self-timer mode.

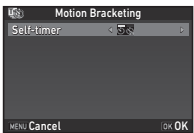

**5** Press **OK**.  
The screen of Step 1 reappears.

**6** Use to set the bracketing order and bracket value.

Available operations	
to the right	Takes pictures using faster shutter speeds than the current setting.
to the left	Takes pictures using slower shutter speeds than the current setting.
	Resets the adjustment value to the default setting.

**7** Press **OK**.  
The camera returns to standby mode.

**8** Shoot.  
Takes three pictures with one release of the shutter.  
The camera returns to standby mode.

- Memo**
- The bracket value can be set in increments of 1/3 EV steps or 1/2 EV steps according to the [1 EV Steps] setting of the **C1** menu.

## Mirror Lock-up Shooting

- 1 Select **MUP** on the Drive Mode screen and press **OK**.

The camera returns to standby mode.

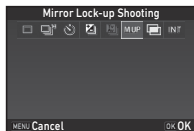

- 2 Press **SHUTTER** halfway, and then fully.  
The mirror pops up and the AE Lock function is activated.
- 3 Press **SHUTTER** fully again.  
The picture is taken and then the mirror returns to its original position.

### Memo

- The mirror automatically returns to its original position if 1 minute elapses after the mirror pops up.

### Caution

- While this function is used, [Shake Reduction] of the menu is fixed to [Off].

## Multi-exposure

- 1 Select on the Drive Mode screen and press **▼**.

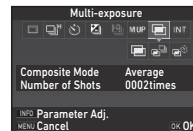

- 2 Use **◀▶** to select , , or .

	Multi-exposure
	Multi-exposure + Continuous Shooting
	Multi-exposure + Self-timer

Proceed to Step 6 if you do not need to change the shooting conditions.

- 3 Press **INFO**.

- 4 Set the shooting conditions.

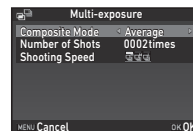

<b>Composite Mode</b>	Select from [Average], [Additive], or [Bright].
<b>Number of Shots</b>	Select from 2 to 2000 times.
<b>Shooting Speed/ Self-timer</b>	Specify the operation mode for the selected shooting mode.



- 5 Press **OK**.  
The screen of Step 1 reappears.

- 6 Press **OK**.  
The camera returns to standby mode.

## 7 Shoot.

The Instant Review image is displayed.

### Available operations during Instant Review

- |   |  |
|---|--|
|  | Discards pictures taken up to that point and takes pictures again from the first picture.  |
| <b>MENU</b>   | Saves pictures taken up to that point and displays the  menu. |

After the specified number of shots are taken, the camera returns to standby mode.

### Memo

- A composite image is created as follows in each Composite Mode.



<b>Average</b>	Creates a composite image with the average exposure.
<b>Additive</b>	Creates a composite image with the cumulatively added exposure.
<b>Bright</b>	Creates a composite image replacing only the portions that are brighter compared with the first image.

## Interval Shooting

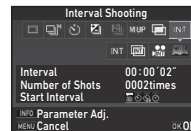
### 1 Select **INT** on the Drive Mode screen and press .



### 2 Use to select **INT**, , , or .

<b>INT</b>	Interval Shooting Takes pictures at set intervals and saves them.
	Interval Composite Takes pictures at set intervals and merges them into a single image.
	Interval Movie Record Takes still pictures at set intervals and saves them as a single movie file (Motion JPEG, file extension: .AVI).
	Star Stream Takes still pictures at set intervals and merges them into a single movie file (Motion JPEG, file extension: .AVI) using Interval Composite.

Proceed to Step 6 if you do not need to change the shooting conditions.

### 3 Press **INFO**.

### 4 Set the shooting conditions.

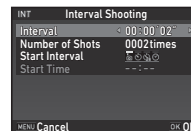



<b>Recorded Pixels</b>	Select from <b>4K</b> , <b>FULL HD</b> , or <b>HD</b> (only for  and ).
<b>Interval</b>	Select from 2 seconds to 24 hours.
<b>Standby Interval</b>	Select from the minimum time or 1 second to 24 hours.
<b>Number of Shots</b>	Select from 2 to 2000 times (from 8 to 2000 times for  and ).
<b>Start Interval</b>	Select when and how to take the first picture from [Now], [Self-timer], or [Set Time].
<b>Start Time</b>	Set the shooting start time when [Start Interval] is set to [Set Time].
<b>Composite Mode</b>	Select from [Average], [Additive], or [Bright] (only for ).
<b>Save Process</b>	Select <input checked="" type="checkbox"/> to save images in the middle of processing (only for ).
<b>Fade-out</b>	Select the fade-out effect level of light trails (only for ).

### 5 Press **OK**.

The screen of Step 1 reappears.

### 6 Press **OK**.

The camera returns to standby mode.

### 7 Press **SHUTTER**.

When [Start Interval] is set to [Now], the first picture is taken. When set to [Set Time], shooting starts at the set time.

To cancel shooting, turn the camera off.

After the specified number of shots are taken, the camera returns to standby mode.

### Memo

- For **INT** and , a new folder is created and the captured images are saved there.
- The shortest time that can be set for [Interval] is 5 seconds when [Digital Filter], [Clarity], or [Skin Tone] is set, and 10 seconds when [HDR Capture] is set.
- The second and later exposures start at the intervals set in [Interval]. If the exposure time is longer than the time set in [Interval], some of the pictures that are supposed to be taken at the set intervals are not actually taken. For example, if the time set in [Interval] is 2 seconds and the exposure time is 3 seconds, the first exposure does not end at the time the second exposure is supposed to start (2 seconds after the start of shooting), and so the second picture is not taken. As a result, Interval Shooting ends before the specified number of shots are taken. In such cases, you can set [Standby Interval] in [11 Interval Shooting Options] of the **C2** menu so that pictures are taken at the set intervals after each exposure ends. The screen displayed in Step 4 varies depending on the [11 Interval Shooting Options] setting.
- For **INT**, , , and , the focus position used when the first picture is taken is locked. In order to perform autofocus for each exposure, set [12 AF in Interval Shooting] to [Adjusts focus for each shot] in the **C2** menu and use the viewfinder for shooting.
- For and , set the camera on a fixed support such as a tripod during shooting.
- For , [Shake Reduction] of the **Q4** menu is fixed to [Off].

## Setting the White Balance

### 1 Press **▼** in standby mode.

The White Balance setting screen appears.

Press **[Fn]** to use Digital Preview when shooting with the viewfinder.

### 2 Select the desired white balance setting.

For **[Fn]**, **[M]**, and **[K]**, turn **[WB]** to select the type of white balance.

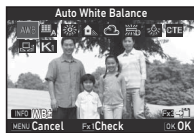

<b>[AWB]</b>	Auto White Balance
<b>[M]</b>	Multi Auto White Balance
<b>[Sun]</b>	Daylight
<b>[House]</b>	Shade
<b>[Cloud]</b>	Cloudy
<b>[Fluorescent]</b>	Fluorescent - Daylight Color
<b>[Fluorescent]</b>	Fluorescent - Daylight White
<b>[Fluorescent]</b>	Fluorescent - Cool White
<b>[Fluorescent]</b>	Fluorescent - Warm White
<b>[Tungsten]</b>	Tungsten
<b>[CTE]</b>	Color Temperature Enhancement
<b>[M]</b>	Manual White Balance 1 to 3
<b>[K]</b>	Color Temperature 1 to 3

#### Available operations when shooting with the viewfinder

<b>[Fn]</b>	Uses Digital Preview to preview the background image with the selected setting applied.
<b>[Fn]</b>	Saves the preview image (only when the image can be saved).

Proceed to Step 5 if you do not need to fine-tune the white balance.

### 3 Press **[INFO]**.

The fine-tuning screen appears.

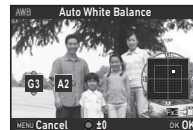

#### Available operations

<b>▲▼</b>	Adjust: Green-Magenta
<b>◀▶</b>	Adjust: Blue-Amber
<b>○</b>	Resets the adjustment value to the default setting.

### 4 Press **[OK]**.

The screen of Step 2 reappears.

### 5 Press **[OK]**.

The camera returns to standby mode.

#### ⚠ Caution

- In **AUTO** mode, the white balance is fixed to [Auto White Balance].
- The Digital Preview operation in Step 1 is disabled when the drive mode is set to [Mirror Lock-up Shooting], [Multi-exposure], or [Interval Shooting].

#### 📌 Memo

- When [Multi Auto White Balance] is set, even if various light sources are present at the shooting location, the camera automatically adjusts the white balance according to the light source of each area. ([Multi Auto White Balance] is not available in **[M]** mode.)
- The following settings for the white balance can be set in the **C2-3** menus.

<b>13 WB Adjustable Range</b>	Fixed, Auto Adjustment
<b>14 AWB in Tungsten Light</b>	Strong Correction, Subtle Correction
<b>15 WB When Using Flash</b>	Auto White Balance, Multi Auto White Balance, Unchanged
<b>16 Color Temperature Steps</b>	Kelvin, Mired

## Adjusting the White Balance Manually

You can measure the white balance at a selected location.

**1** Select  in Step 2 of “Setting the White Balance” (p.72).

**2** Use  to select 1 to 3.  
1 to 3 are the locations where you can store three different manual white balance settings.

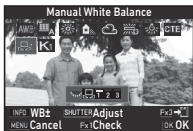

**3** Under the light you wish to measure the white balance of, select a white area as the subject, and press **SHUTTER** fully.

The captured image is displayed.

**4** Use  to specify the measuring area.



Press  to return the measuring area to the center.



**5** Press **OK**.

The White Balance setting screen reappears.  
[The operation could not be completed correctly] appears when measuring is unsuccessful. Press **OK** to remeasure the white balance.

### Memo

- You can copy the white balance settings of a captured image and save them as  1 to  3 in [Save as Manual WB] of the playback mode palette. (p.81)

## Adjusting the White Balance with Color Temperature

You can specify the white balance with the color temperature.

**1** Select **K** in Step 2 of “Setting the White Balance” (p.72).

**2** Use  to select 1 to 3.



**3** Press **INFO**.

**4** Adjust the color temperature.

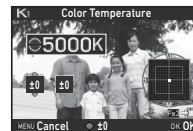
Set the color temperature value within the range from 2,500K to 10,000K.





### Available operations

- |   |  |
|---|--|
|  | Changes the color temperature in increments of 100 Kelvin.   |
|  | Changes the color temperature in increments of 1,000 Kelvin. |
|  | Fine-tunes the color temperature.                            |

**5** Press **OK**.

The White Balance setting screen reappears.

### Memo

- Select [Mired] in [16 Color Temperature Steps] of the **C3** menu to set the color temperature in mired units. The color temperature can be changed in 20 mired units with , and 100 mired units with . However, figures are converted to and displayed in Kelvin.

## Controlling the Image Finishing Tone

When you want to take pictures with a slightly different style, you can set the desired picture style before shooting. Try out the various settings, and find your best picture style.

### Custom Image



**1** Select [Custom Image] in the 1 or 1 menu and press **▶**.

The Custom Image setting screen appears.

**2** Select an image finishing tone.

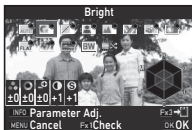

Auto Select	Muted
Bright	Flat
Natural	Bleach Bypass
Portrait	Reversal Film
Landscape	Monochrome
Vibrant	Cross Processing
Radiant	

#### Available operations when shooting with the viewfinder

<b>Fx1</b>	Uses Digital Preview to preview the background image with the selected setting applied.
<b>Fx3</b>	Saves the preview image (only when the image can be saved).

Proceed to Step 6 when [Auto Select] is selected or if you do not need to change the parameters.

**3** Press **INFO**.

The parameter setting screen appears.

**4** Set the parameters.



#### Available operations

	Selects a parameter.
	Adjusts the value.
	Switches between [Contrast], [Highlight Adjustment], and [Shadow Adjustment].
	Switches between [Sharpness], [Fine Sharpness], and [Extra Sharpness]. (Not available in  mode.)
	Resets the adjustment value to the default setting.

**5** Press **MENU**.

The screen of Step 2 reappears.

The adjustment values for parameters are displayed.

**6** Press **MENU** twice.

The camera returns to standby mode.

#### Caution

- In **AUTO** mode, [Custom Image] is fixed to [Auto Select].
- The Digital Preview operation in Step 2 is disabled when the drive mode is set to [Mirror Lock-up Shooting], [Multi-exposure], or [Interval Shooting].
- When [Custom Image] is assigned to the function dial, you can change the image finishing tone using the Smart Function. (p.21, p.105) By default, [Custom Image] is assigned to C1.

## Saving the Cross Processing Settings of a Captured Image

When [Cross Processing] is set to [Random], the outcome varies each time a picture is taken. If a cross processed image that you like is taken, you can save the Cross Processing settings used in the image so that you can repeatedly use the same settings.

### 1 Press **▼** in single image display of playback mode.

The playback mode palette appears.

### 2 Select [Save Cross Processing] and press **OK**.

The camera searches for cross processed images starting from the most recent image taken.

[No cross processed image] appears if there are no cross processed images.

### 3 Use to select a cross processed image.



### 4 Select the “Favorite” number 1, 2, or 3 to save the settings, and press **OK**.

The settings of the selected image are saved as your “Favorite” settings.

### Memo

- The saved Cross Processing settings can be loaded by selecting [Cross Processing] in Step 2 of “Custom Image” (p.74), and selecting one of the Favorite settings 1 to 3 for the parameter.

## Digital Filter



### 1 Select [Digital Filter] in the 3 or 2 menu and press **▶**.

The Digital Filter setting screen appears.

### 2 Select a filter.

Select [No Filter] to not shoot with a digital filter.



Extract Color  
Replace Color  
Toy Camera  
Retro  
High Contrast

Shading  
Invert Color  
Unicolor Bold  
Bold Monochrome

### Available operations when shooting with the viewfinder

- FX1** Uses Digital Preview to preview the background image with the selected setting applied.
- FX3** Saves the preview image (only when the image can be saved).

Proceed to Step 6 if you do not need to change the parameters.

### 3 Press **INFO**.

The parameter setting screen appears.

## 4 Set the parameters.



### Available operations

- ▲▼ Selects a parameter.
- ◀▶ Adjusts the value.

## 5 Press **OK**.

The screen of Step 2 reappears.

## 6 Press **OK**.

## 7 Press **MENU**.

The camera returns to standby mode.

### ⚠ Caution

- This function cannot be used in combination with some other functions. (p.115)
- The Digital Preview operation in Step 2 is disabled when the drive mode is set to [Mirror Lock-up Shooting], [Multi-exposure], or [Interval Shooting].
- Depending on the filter used, it may take longer to save images.

### 📝 Memo

- Still pictures can also be processed with digital filters in playback mode. (p.87)

## Correcting Images

### Brightness Adjustment

#### Highlight Correction Shadow Correction

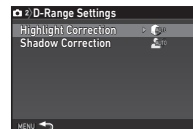

Expands the dynamic range and enables a wider range of tones to be recorded by the CMOS sensor and reduces the occurrence of overexposed/underexposed areas. Set the correction functions from [D-Range Settings] of the 2 or 2 menu.

#### ⚠ Caution

- When the sensitivity is set to less than ISO 200, [Highlight Correction] cannot be set to [On].

#### 📝 Memo

- [Highlight Correction] in mode can be set to [Auto] or [Off].

Takes three consecutive images at three different exposure levels to create a single composite image with them.

- 1 Select [HDR Capture] in the **CAMERA 3** menu and press **▶**.  
The [HDR Capture] screen appears.

- 2 Select a capture type and press **OK**.

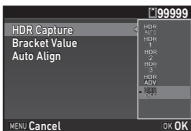

- 3 Set the range in which to change the exposure in [Bracket Value].

Select from [±1EV], [±2EV], or [±3EV].

- 4 Set whether to use Auto Align or not.

<input checked="" type="checkbox"/>	Uses Auto Align.
<input type="checkbox"/>	Does not use Auto Align.

- 5 Press **MENU** twice.

The camera returns to standby mode.

#### **Memo**

- The capture type can also be changed by the Smart Function. (p.21)

#### **Caution**

- In **B** or **AF** mode, HDR Capture is disabled.
- This function cannot be used in combination with some other functions. (p.115)
- When the drive mode is set to [Interval Shooting] or [Interval Movie Record], [Auto Align] is fixed to  (Off).
- When [Auto Align] is set to  (Off), [Shake Reduction] of the **CAMERA 4** menu is fixed to [Off].
- For HDR Capture, multiple images are combined together to create a single image, so it may take time to save the image.

The following features can be set in [Lens Correction] of the **CAMERA 4** menu.

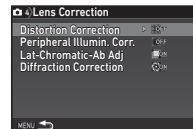

<b>Distortion Correction</b>	Reduces distortions occurring due to lens properties.
<b>Peripheral Illumin. Corr.</b>	Reduces peripheral light fall-off occurring due to lens properties.
<b>Lat-Chromatic-Ab Adj</b>	Reduces lateral chromatic aberrations occurring due to lens properties.
<b>Diffraction Correction</b>	Corrects blur caused by diffraction when using a small aperture.

#### **Memo**

- Corrections can only be made when a compatible lens is attached. (p.116) The features are disabled when an accessory such as a rear converter is attached between the camera and the lens.
- When [File Format] is set to [RAW] or [RAW+] in [Image Capture Settings] of the **CAMERA 2** menu, correction information is saved as a RAW file parameter and you can select whether to apply the correction to the images when developing them. When developing RAW images, the correction feature [Color Fringe Correction] is also available. (RAW Development, p.90)

## Quality Level and Texture Adjustment

### Adjusting the Texture



The texture and surface details of an image can be adjusted in the range of -4 to +4.

Set in [Clarity] of the 3 menu.



### Enhancing the Skin Tone



The skin tone of portraits can be enhanced.

Set in [Skin Tone] of the 3 menu.



<b>Type1</b>	Determines the skin tone of the subject by the Face Detection function, and creates a natural-looking skin tone. (Available only when a face is detected.)
<b>Type2</b>	Softens the entire image, and makes skin irregularities less noticeable.

## Shooting High-Definition Images



Pixel Shift Resolution is the feature that enables outputting a high-definition image of stationary objects by merging multiple images shifted pixel by pixel using the Shake Reduction mechanism.

### 1 Select [Pixel Shift Resolution] in the 3 menu and press **▶**.

The [Pixel Shift Resolution] screen appears.

### 2 Select [On] or [Off] in [Pixel Shift Resolution] and press **OK**.

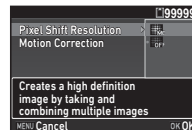

### 3 Select [On] or [Off] in [Motion Correction] and press **OK**.

When [Motion Correction] is set to [On], mosaic-pattern noise is corrected when a moving object is detected, and a composite image is created.

### 4 Press **MENU** twice.

The camera returns to standby mode.

### 5 Press **SHUTTER**.

Multiple images are taken using the electronic shutter with one release of the shutter.

The captured images are displayed in turn, and then they are merged into a single image.

### ⚠ Caution

- In **B** or mode, Pixel Shift Resolution is disabled.
- This function cannot be used in combination with some other functions. (p.115)
- [AA Filter Simulator] and [Shake Reduction] of the 4 menu are fixed to [Off].
- [Shutter Mode Selection] of the 2 menu is fixed to [Electronic Shutter].



## Memo

- When taking pictures with Pixel Shift Resolution, use a tripod and mount the camera on it securely. The use of Pixel Shift Resolution in combination with Self-timer or Mirror Lock-up Shooting is recommended.

## Reducing Color Moiré



By shaking the Shake Reduction unit, a moiré reduction effect simulating that of a low-pass filter can be achieved.

- 1 Select **[AA Filter Simulator]** in the 4 menu and press **▶**.
- 2 Select a capture type and press **OK**.

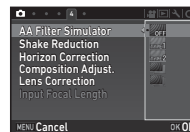

<b>Type1</b>	Takes pictures while balancing the resolution and moiré reduction.
<b>Type2</b>	Prioritizes the moiré reduction.
<b>Bracketing (2 images)</b>	Takes two consecutive images in order of [Off] and [Type2].
<b>Bracketing (3 images)</b>	Takes three consecutive images in order of [Off], [Type1], and [Type2].

## Caution

- This function cannot be used in combination with some other functions. (p.115)
- In **B** mode, [Bracketing] cannot be selected.
- [Bracketing] is available only when the drive mode is set to [Single Frame Shooting] or [Self-timer] (12 seconds, 2 seconds).
- When [HDR Capture] in the 3 menu is set, [AA Filter Simulator] is fixed to [Off].
- When the shutter speed is faster than 1/1000 seconds, the full effect of this function cannot be achieved.

## Memo

- When [AA Filter Simulator] is assigned to the function dial, you can change the capture type using the Smart Function. (p.21, p.105) By default, [AA Filter Simulator] is assigned to C2.

## Composition Adjustment



By using the Shake Reduction mechanism, the composition of the image can be adjusted. Use this function when you want to adjust the composition, such as when using a tripod while shooting with Live View.

**1** Select **[On]** in **[Composition Adjust.]** of the **4** menu.

**2** Press **MENU**.

The camera returns to standby mode.

**3** Set the **📷/[LV]/📷** switch to **[LV]**.

The Live View image is displayed and the message [Adjust the composition of the image] appears.

**4** Adjust the composition.

The amount of adjustment (the number of steps) is displayed at the top right of the screen.



### Available operations



Moves the composition of the image (up to 16 steps).



Corrects the tilt of the composition (up to 8 steps. Not available when the amount of adjustment steps in vertical and horizontal directions is 8 or more).



Resets the adjustment values to the default settings.

**5** Press **OK**.

The camera returns to standby mode in Live View.

### Caution

- You cannot use this function when the ASTROTRACER function is used.

### Memo











- When [Grid Display] is set to [On] in [Live View] of the **5** menu, grid lines are displayed on the screen of Step 4.
- The adjusted composition is saved even if Live View is ended or the camera is turned off. To reset the saved adjustment value when the camera is turned off, set [Composition Adjust.] to  (Off) in [Memory] of the **5** menu. (p.110)

## Playback Mode Palette Items

Playback functions can be set from the playback mode palette as well as the  1 menu (p.31).

Press  in single image display (Standard Information Display or No Information Display) of the playback mode to display the playback mode palette.



Item	Function	Page
 <b>Image Rotation</b> *1	Changes the rotation information of an image.	p.84
 <b>Digital Filter</b> *1	Processes images with digital filters.	p.87
 <b>Color Moiré Correction</b> *1 *2	Reduces color moiré in images.	p.87
 <b>Resize</b> *1 *2	Changes the number of recorded pixels of an image.	p.86
 <b>Cropping</b> *1	Crops out only the desired area of an image.	p.86
 <b>Protect</b>	Protects images from being accidentally erased.	p.110
 <b>Slideshow</b>	Plays back images one after another.	p.84
 <b>Save as Manual WB</b> *1	Saves the white balance settings of a captured image as Manual White Balance.	p.73
 <b>Save Cross Processing</b>	Saves the settings used for an image captured in Cross Processing mode of Custom Image as your “Favorite” settings.	p.75
 <b>RAW Development</b> *3	Develops RAW images into JPEG or TIFF images and saves them as new files.	p.90

Item	Function	Page
 <b>Movie Edit</b> *4	Divides a movie or deletes unwanted segments.	p.89

\*1 Not available when a TIFF image or movie is displayed.

\*2 Not available when a RAW image or TIFF image is displayed.

\*3 Available only if a RAW image has been saved.

\*4 Available only when a movie is displayed.

# Changing the Playback Method

## Displaying Multiple Images

You can display 6, 12, 20, 35, or 80 thumbnail images at the same time.

- 1 Turn  to the left in playback mode.  
The multi-image display screen appears.



### Available operations

 Moves the selection frame.

 Shows the next/previous page.

 Shows the display style selection screen.



 Deletes the selected images.

- 2 Press **OK**.  
The selected image appears in single image display.

## Deleting Selected Images

- 1 Press  in Step 1 of “Displaying Multiple Images” (p.82).
- 2 Select the images to delete.





### Available operations

   Moves the selection frame.

 Confirms/cancels the selection of the image to delete.

 Selects the range of images to delete.

 Shows the selected image in single image display.  
Use  to select a different image.

In the upper left area of the monitor, the number of selected images is displayed.

- 3 Press .  
The delete confirmation screen appears.
- 4 Select **[Delete]** and press **OK**.

### Memo

- You can select up to 500 images at a time.
- Protected images cannot be selected.
- You can delete the images selected individually along with the images selected by specifying the range to delete.
- Use the same steps to select multiple images for the following functions.
  - RAW Development (p.90)
  - Protect (p.110)

## Displaying Images by Folder

- 1 Turn  to the left in Step 1 of “Displaying Multiple Images” (p.82).

The folder display screen appears.



### Available operations

   Moves the selection frame.

 Deletes the selected folder.

- 2 Press **OK**.

The images in the selected folder are displayed.

## Deleting a Folder

- 1 Select the folder to delete in Step 1 of “Displaying Images by Folder” (p.83), and press .

The delete confirmation screen appears.

- 2 Select **[Delete]** and press **OK**.

The selected folder and all the images in it are deleted. When protected images are in the folder, select **[Delete all]** or **[Leave all]**.

## Displaying Images by Shooting Date

Images are grouped and displayed by shooting date.

- 1 Press **INFO** in Step 1 of “Displaying Multiple Images” (p.82).



The display style selection screen appears.

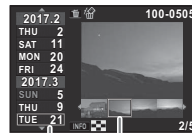

- 2 Select **[Calendar Filmstrip Display]**.



Shooting date      Thumbnail date

### Available operations

  Selects a shooting date.

  Selects an image taken on the selected shooting date.

 to the right Shows the selected image in single image display.

 Deletes the selected image.

- 3 Press **OK**.

The selected image appears in single image display.

## Playing Back Images Continuously

### 1 Select [Slideshow] in the playback mode palette.

A slideshow starts.

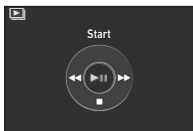

#### Available operations

<b>OK</b>	Pauses/resumes playback.
◀	Displays the previous image.
▶	Displays the next image.
▼	Stops playback.
🔊	Adjusts the sound volume of the movie.

After all images are played back, the camera returns to single image display mode.

#### Memo

- You can change the [Display Duration], [Screen Effect], [Repeat Playback], and [Auto Movie Playback] settings for a slideshow in [Slideshow] of the **1** menu. A slideshow can also be started from the Slideshow setting screen.

When [Auto Movie Playback] is set to **Off**, press **OK** during a slideshow to play back a movie.

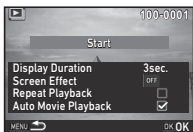

## Displaying Rotated Images

Image rotation information is saved when you take pictures with the camera held vertically. When [Auto Image Rotation] of [LCD Display] in the **1** menu is set to **On**, the image is automatically rotated based on the rotation information during playback (default setting).

The rotation information of an image can be changed by following the procedure below.

### 1 Display the image to edit in single image display.

### 2 Select [Image Rotation] in the playback mode palette.

The selected image is rotated in 90° increments and the four thumbnail images are displayed.

### 3 Use ▲▼◀▶ to select the desired rotation direction and press **OK**.

The image rotation information is saved, and the camera returns to single image display mode.



#### Caution

- When [20 Save Rotation Info] is set to [Off] in the **C3** menu, image rotation information is not saved.
- You cannot change image rotation information in the following cases.
  - Protected images
  - Images without a rotation information tag
- When [Auto Image Rotation] of [LCD Display] in the **1** menu is set to **Off**
- Movie files cannot be rotated.

## Connecting the Camera to an AV Device

Connect to an AV device, such as a TV, equipped with an HDMI<sup>®</sup> terminal to display Live View images while shooting or to play back images in playback mode.

The USB terminal (micro B) of the camera supports SlimPort<sup>®</sup>. Make sure to have a commercially available HDMI<sup>®</sup> adapter and compatible HDMI<sup>®</sup> cable.

- 1 Turn the AV device and camera off.**
- 2 Connect the HDMI<sup>®</sup> adapter and HDMI<sup>®</sup> cable.**
- 3 Open the terminal cover of the camera, and connect the HDMI<sup>®</sup> adapter to the USB/video output terminal.**

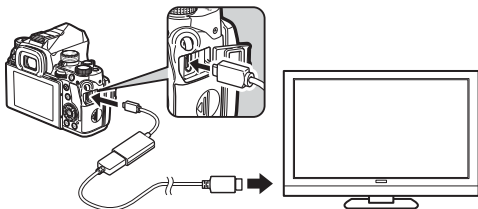

- 4 Connect the other end of the HDMI<sup>®</sup> cable to the input terminal on the AV device.**
- 5 Turn the AV device and camera on.**

The camera turns on in video output mode, and the camera information is displayed on the screen of the connected AV device.

### ⚠ Caution

- While the camera is connected to an AV device, nothing is displayed on the camera monitor. Also, you cannot adjust the sound volume on the camera. Adjust the volume on the AV device.
- Some HDMI<sup>®</sup> adapters are not compatible with this camera. Proper operation has been confirmed with the following HDMI<sup>®</sup> adapter:  
SP6001 (Analogix Semiconductor, Inc.)
- Do not supply power to an HDMI<sup>®</sup> adapter from an external power source. This may cause the camera to malfunction.
- Images may not be output due to incompatibility with the used HDMI<sup>®</sup> cable. Use an HDMI<sup>®</sup> cable which does not incorporate electronic circuits.
- MHL<sup>®</sup>-to-HDMI<sup>®</sup> adapters cannot be used.

### 📖 Memo

- Check the operating manual of the AV device and select a suitable input terminal for connecting the camera.
- By default, the maximum resolution supported by both the AV device and camera is automatically selected. If it fails to play back images properly, change the setting in [Video Out Resolution] of the 3 menu.

## Editing and Processing Images

### Changing the Image Size

#### ⚠ Caution

- Only JPEG images captured with this camera can be resized or cropped.
- Images already resized or cropped to the minimum file size cannot be processed.

### Changing the Number of Recorded Pixels

Changes the number of recorded pixels of the selected image, and saves it as a new file.

**1** Display the image to edit in single image display.

**2** Select **[Resize]** in the playback mode palette.

The screen to select the number of recorded pixels appears.

**3** Use **◀▶** to select the number of recorded pixels and press **OK**.

You can select an image size smaller than that of the original image.

The save confirmation screen appears.

**4** Select **[Save]** and press **OK**.



### Cropping Out Part of the Image

Crops out only the desired area of the selected image and saves it as a new file.

**1** Display the image to edit in single image display.





**2** Select **[Cropping]** in the playback mode palette.

The cropping frame to specify the size and position of the area to crop appears on the screen.

**3** Specify the size and position of the area to crop by using the cropping frame.



#### Available operations

	Changes the size of the cropping frame.
	Moves the cropping frame.
	Changes the Aspect Ratio or Image Rotation setting.
	Rotates the cropping frame (only when possible).

**4** Press **OK**.

The save confirmation screen appears.

**5** Select **[Save]** and press **OK**.



## Correcting Color Moiré

Reduces color moiré in images.

- 1 Display the image to edit in single image display.
- 2 Select [Color Moiré Correction] in the playback mode palette.  
If the image cannot be edited, [This image cannot be processed] appears.

- 3 Use ◀▶ to select the correction level and press **OK**.

The save confirmation screen appears.



- 4 Select [Save] and press **OK**.

### ⚠ Caution

- The Color Moiré Correction function can only be used for JPEG images captured with this camera.

## Processing Images with Digital Filters

- 1 Display the image to edit in single image display.
- 2 Select [Digital Filter] in the playback mode palette.

The screen to select a filter appears.

- 3 Select a filter.

Use 🌞 to select a different image.



Base Parameter Adj	Sketch
Extract Color	Water Color
Replace Color	Pastel
Toy Camera	Posterization
Retro	Miniature
High Contrast	Soft
Shading	Starburst
Invert Color	Fish-eye
Unicolor Bold	Slim
Bold Monochrome	Monochrome
Tone Expansion	

Proceed to Step 7 if you do not need to change the parameters.

- 4 Press **INFO**.

The parameter setting screen appears.

## 5 Set the parameters.



### Available operations

- ▲▼ Selects a parameter.
- ◀▶ Adjusts the value.

## 6 Press **OK**.

The screen of Step 3 reappears.

## 7 Press **OK**.

The save confirmation screen appears.

## 8 Select **[Apply additional filter(s)]** or **[Save]** and press **OK**.

Select **[Apply additional filter(s)]** when you want to apply additional filters to the same image. The screen of Step 3 reappears.

### ⚠ Caution

- Only JPEG and RAW images captured with this camera can be edited with the digital filters.
- RAW images captured using HDR Capture or Pixel Shift Resolution cannot be processed with Digital Filter.

### 📝 Memo

- Up to 20 filters, including the digital filter used during shooting (p.75), can be applied to the same image.

## Recreating Filter Effects

Retrieves the filter effects of the selected image and applies the same filter effects to other images.

### 1 Display a filter-processed image in single image display.

### 2 Select **[Digital Filter]** in the playback mode palette.

### 3 Select **[Recreating filter effects]** and press **OK**.

The filter effects used for the selected image appear.



### 4 To check the parameter details, press **INFO**.

Press **INFO** again to return to the previous screen.

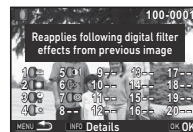

### 5 Press **OK**.

The image selection screen appears.

### 6 Use to select an image for applying the same filter effects, and press **OK**.

You can only select an image that has not been processed with a filter.

The save confirmation screen appears.



### 7 Select **[Save]** and press **OK**.

### 📝 Memo

- If **[Searching for original image]** is selected in Step 3, the original image prior to digital filter application can be retrieved.

## Editing Movies

- 1 Display the movie to edit in single image display.
- 2 Select **[Movie Edit]** in the playback mode palette. The movie editing screen appears.

- 3 Select the point where you want to divide the movie.

The frame at the dividing point is displayed at the top of the screen.

Up to four points can be selected to divide the original movie into five segments.

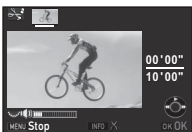

### Available operations

▲	Plays back/pauses a movie.
▶	Forwards a frame (when paused).
Press and hold ▶	Fast-forwards playback.
◀	Reverses a frame (when paused).
Press and hold ◀	Fast-reverses playback.
🔊	Adjusts the sound volume.
INFO	Confirms/cancels the selected dividing point.

Proceed to Step 7 if you do not want to delete any segment.

- 4 Press **[Delete]**.

The screen to select the segments to delete is displayed.

- 5 Use **◀▶** to move the selection frame and press **OK**.

The segments to delete are specified. (Multiple segments can be deleted at once.)

Press **OK** again to cancel the selection.



- 6 Press **[MENU]**.

The screen of Step 3 reappears.

- 7 Press **OK**.

The save confirmation screen appears.

- 8 Select **[Save]** and press **OK**.

### ● Memo

- Select dividing points in chronological order from the beginning of the movie. When canceling the selected dividing points, cancel each of them in reverse order (from the end of the movie to the beginning). In an order other than specified, you can neither select dividing points nor cancel the selections of the dividing points.

## Developing RAW Images

You can develop RAW images into JPEG or TIFF images, and save them as new files.

### 1 Select [RAW Development] in the playback mode palette.

The screen for selecting the processing type appears.

### 2 Select the desired option and press **OK**.

Select single image	Develops an image.
Select multiple images	Develops up to 500 images with the same settings.
Select a folder	Develops up to 500 images in the selected folder with the same settings.

When [Select single image] is selected, proceed to Step 6. The image/folder selection screen appears.

### 3 Select image(s) or a folder.

Proceed to Step 5 if a folder is selected.

🔗 How to select image(s) (p.82).

### 4 Press **INFO**.

The screen for selecting the parameter setting method appears.

### 5 Select the parameter setting method and press **OK**.



Develop images as shot	Allows you to change only File Format, Aspect Ratio, JPEG Recorded Pixels, JPEG Quality, and Color Space.
Develop images with modified settings	Allows you to change all setting items.

### 6 Select the setting item to change.



White Balance	Distortion Correction
Custom Image	Peripheral Illumin. Corr.
Sensitivity	Lat-Chromatic-Ab Adj
Clarity	Diffraction Correction
Skin Tone	Color Fringe Correction
Digital Filter	File Format
HDR Capture/	Aspect Ratio
Pixel Shift Resolution	JPEG Recorded Pixels
Shadow Correction	JPEG Quality
High-ISO NR	Color Space

#### Available operations

	Selects a different image (when in single image display).
	Selects a parameter.
	Changes the value.
<b>INFO</b>	Reviews the image.
<b>OK</b>	Makes detailed settings.

### 7 Use **▲▼◀▶** to select [JPEG→] or [TIFF→]. Turn to change the file format.

### 8 Press **OK**.

The save confirmation screen appears.

### 9 Select [Save] and press **OK**.

When [Select single image] is selected, select [Continue] or [Exit], and press **OK**.

## **Caution**

- Only RAW images captured with this camera can be developed.
- For RAW images captured when the drive mode is set to [Multi-exposure] or [Interval Composite], the images are developed with the Lens Correction settings used during shooting. The Lens Correction settings cannot be changed when developing RAW images.

## **Memo**

- When [Select multiple images] or [Select a folder] is selected in Step 2, a folder with a new number is created, and the JPEG or TIFF images are stored in it.
- For [HDR Capture] and [Pixel Shift Resolution], the parameters of either one of the two functions used during shooting can be changed.
- With the provided software “Digital Camera Utility 5”, you can develop RAW images on a computer.

## Using the Camera with a Computer

Connect the camera to a computer using a USB cable. Make sure to have a commercially available USB cable equipped with a micro B terminal.

### Setting the Connection Mode



Set the connection mode in [USB Connection] of the  3 menu according to the operation to be performed with a computer.

<b>MSC</b> (default setting)	Allows you to copy the data on the memory card to a computer by making the computer recognize the camera as a removable disk. (p.92)
<b>PTP</b>	Allows you to perform tethered shooting by operating the camera with a computer. (p.93)

#### Memo

- Refer to "Operating Environment for USB Connection and Provided Software" (p.132) for system requirements to connect the camera to a computer with a commercially available USB cable and to use the software.
- If you intend to use the camera continuously for a long period, the use of the optional AC adapter kit is recommended. (p.40)

## Copying an Image on the Memory Card

**1** Set [USB Connection] to [MSC] in the  3 menu.

**2** Turn the camera off.

**3** Open the terminal cover of the camera, and connect the USB cable to the USB/video output terminal.

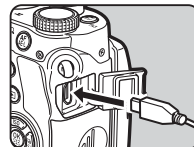

**4** Connect the USB cable to the USB port of the computer.

**5** Turn the camera on.

The camera is recognized as a removable disk.

**6** Save the captured images to the computer.

**7** Disconnect the camera from the computer.

#### Caution

- The camera cannot be operated while it is connected to a computer. To operate the camera, terminate the USB connection on the computer first, then turn off the camera and remove the USB cable.
- If the "KP" dialog appears on the computer screen in Step 5, select [Open folder to view files] and click the OK button.

## Operating the Camera with a Computer

You can perform tethered shooting with the camera connected to a computer using the optional "IMAGE Transmitter 2" software. Captured images can be directly saved to the computer.

- 1 Set [USB Connection] to [PTP] in the **3** menu.
- 2 Turn the camera off.
- 3 Connect the camera to a computer using a USB cable.  
↳ Connecting the camera to a computer (p.92)
- 4 Turn the camera on.
- 5 Start "IMAGE Transmitter 2" on the computer. "IMAGE Transmitter 2" is started and the computer recognizes the camera.

### Memo

- For details on "IMAGE Transmitter 2", refer to the "User Guide [Operation]" available at the following site.  
[http://www.ricoh-imaging.co.jp/english/support/download\\_manual.html](http://www.ricoh-imaging.co.jp/english/support/download_manual.html)
- During tethered shooting, the shutter release always has priority regardless of the [AF.S Setting] setting of [AF with Live View] in the **1** menu. (p.61)



## Using the Camera with a Communication Device

This camera has a built-in Wi-Fi™ function. By directly connecting to a communication device such as a smartphone and tablet via wireless LAN, the camera can be operated from the communication device and images can be shared with others via social networks or e-mail.

### Enabling the Wi-Fi™ Function

The Wi-Fi™ function is disabled when the camera is turned on. Enable the function using one of the following methods.

- Setting from the menus (p.94)
- Using the **Fx1** button (p.94)

When the Wi-Fi™ function is enabled, a beep sounds and the  (white) icon indicating the wireless LAN status is displayed on the status screen and Live View screen. When  (gray) is displayed, a connection with the communication device is not established correctly.



### Memo

- Even after the Wi-Fi™ function is enabled, it returns to an inactive state when the camera is turned off and on again.
- Auto Power Off is not available while a Wi-Fi™ connection is established or images are being transferred. If Auto Power Off is activated while a connection is not established, the Wi-Fi™ function is disabled. The function is enabled when the camera recovers from Auto Power Off.
- The Wi-Fi™ function is disabled during the USB connection or while outputting image data.

### Caution

- Do not attempt to use the Wi-Fi™ function in a location where the use of wireless LAN devices is restricted or prohibited, such as on airplanes.
- When using the Wi-Fi™ function, observe local laws and regulations governing radio communication.
- If a memory card with a built-in wireless LAN function (such as an Eye-Fi card or a Flucard) is used, radio wave interference may occur. When this occurs, disable the Wi-Fi™ function of the camera.

## Setting from the Menu



# 1 Select [Wi-Fi] in the 3 menu and press .

The [Wi-Fi] screen appears.

# 2 Set [Action Mode] to [On].

Select [Off] to disable the Wi-Fi™ function.

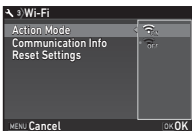

# 3 Press **MENU** twice.

## Memo

- In Step 2, select [Communication Info] to check the SSID, Password, and MAC Address of the wireless LAN. Or, select [Reset Settings] to reset the settings to their default values.

Using the **Fx1** Button

If you use the Wi-Fi™ function frequently, assign the function to the **Fx1** button so that you can easily turn the function on and off with a simple button operation.

# 1 Assign [Wi-Fi] to **Fx1**.

Setting the **Fx1** button operation (p.102)

# 2 Press and hold **Fx1** in standby mode.

A beep sounds and [Wi-Fi enabled] appears on the monitor. Press and hold **Fx1** again to disable the Wi-Fi™ function.

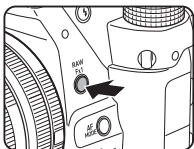

## Operating the Camera with a Communication Device

The following functions can be used by connecting the camera to a communication device via Wi-Fi™ and using the dedicated application "Image Sync".

<b>Remote Capture</b>	Displays the Live View image of the camera on the communication device, and enables controlling exposure settings and shooting by operating the communication device.
<b>Image View</b>	Displays the images saved on the memory card inserted in the camera on the communication device, and imports the images to the communication device.

Image Sync supports iOS and Android™, and can be downloaded from the App Store or Google Play™. For the supported operating system and other details, refer to the download site.

## Memo

- The Image Sync screenshots used in this manual are the ones under development and may differ from the actual display. The screen layout and elements may be also changed due to causes such as the version upgrade of the application or operating system.
- For details on how to operate the communication device, refer to the operation manual of the device.



## Connecting the Camera and a Communication Device

Connect the camera and a communication device via Wi-Fi™, and start Image Sync installed on the communication device.

### When an Android Device is Used

**1** Set the wireless LAN (Wi-Fi™) function to ON on the communication device.

**2** Start Image Sync on the communication device.

The camera selection screen appears on the communication device.

**3** Tap [PENTAX KP].

The [Choose a Network] screen appears on the communication device.

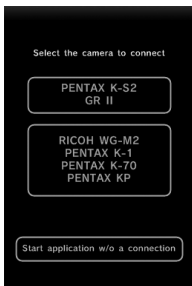

**4** Tap [PENTAX\_xxxxxx] in the [Network List].

The [Enter Password] screen appears.



**5** Enter the password, and tap [Connect].

A Wi-Fi™ connection is established between the camera and the communication device.

The list of images appears on the Image Sync screen.

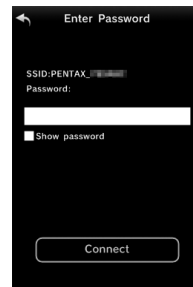

### ● Memo

- Refer to [Communication Info] in [Wi-Fi] of the ↖3 menu for the default password. (p.94)

## When an iOS Device is Used

- 1 Set the wireless LAN (Wi-Fi™) function to ON on the communication device.
- 2 Tap [PENTAX\_XXXXXX] in the list of detected Wi-Fi™ networks.
- 3 Enter the password, and tap [Join].  
A Wi-Fi™ connection is established between the camera and the communication device.
- 4 Start Image Sync on the communication device.  
Image Sync is started, and the list of images appears.



## Screens of Image Sync

Flick left or right on the screen to switch operation modes.

## Application image list

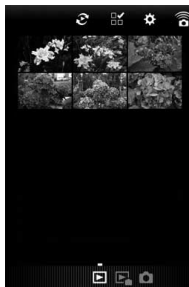

## Camera image list



## Camera mode



## Memo

- You can change the operation mode also by tapping the buttons displayed at the bottom of the screen.

## Shooting with a Communication Device

The Live View image of the camera and buttons for shooting are displayed on the shooting screen of Image Sync.

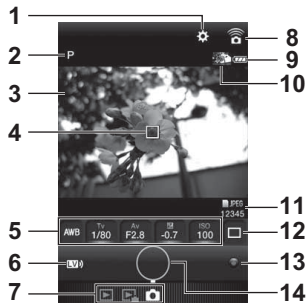

- 1 Settings (p.100)
- 2 Capture mode
- 3 Live View
- 4 AF frame
- 5 White Balance, Shutter Speed, Aperture value, EV Compensation, Sensitivity
- 6 Live View on/off
- 7 Operation modes
- 8 Communication icon
- 9 Battery level
- 10 Thumbnail of the last captured image  
(When tapped, the camera image list is displayed.)
- 11 File Format, Image storage capacity
- 12 Drive Mode
- 13 Green button
- 14 Shutter release button

**1** Set up the basic settings on the camera.

**2** Check the Live View image on the shooting screen of Image Sync.



**3** Change the settings using Image Sync as necessary.



**5**

Sharing

Tap an item and select a value from the list.



#### 4 When the focus method is set to **AF**, tap the position where you want to perform autofocus in the Live View image.

Autofocus is performed at the tapped position.

#### 5 Tap the shutter release button.

The captured image is displayed as a thumbnail.

#### Caution

- The capture mode (📷 (still picture) mode or 🎥 (movie) mode) can be changed by using the capture mode selector switch on the camera.
- Shooting with Image Sync is not available when the drive mode is set to [Continuous Shooting (H)], [Interval Shooting], [Interval Composite], [Interval Movie Record], or [Star Stream].
- The captured images are saved to the memory card inserted in the camera. Shooting cannot be performed if there is not enough available space on the memory card.

#### Memo

- Shooting can also be performed by tapping the Live View image. Set in [Touch AF] on the [Settings] screen. (p.100)
- While shooting with Image Sync, the autofocus system operates in **AFS** mode regardless of the autofocus mode setting, and the shutter release has priority regardless of the [AF.S Setting] setting of [AF with Live View] in the 📷1 menu. (p.61)

## Viewing Images

You can view the images saved either in the camera or in the communication device.

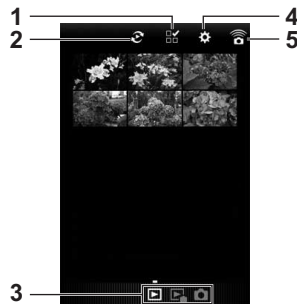

- 1 Multiple image selection button
- 2 Album selector button (available for the application image list only)
- 3 Operation modes
- 4 Settings (p.100)
- 5 Communication icon

Tap the thumbnail image to view it in single image display and check its shooting information.



### Touch operations

- |                         |                                |
|-------------------------|--------------------------------|
| <b>Flick left/right</b> | Shows the previous/next image. |
| <b>Pinch out/in</b>     | Magnifies/reduces the image.   |

## Selecting the Image Storage Location

When viewing images in application image list display, you can select the image storage location (album) from “Application” or “Gallery” (or “Camera Roll”).

**1** Tap .

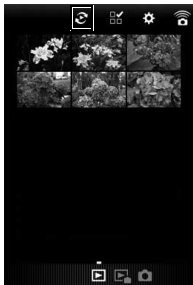

**2** Select the album.

The images in the selected album are displayed.

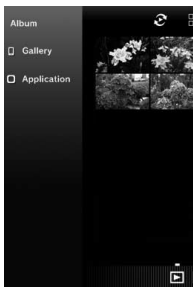

## Selecting Multiple Images

**1** Tap .



**2** Tap the images to select.  
Blue check marks appear.



**3** Touch and hold one of the selected images.

## 4 Select the desired action.

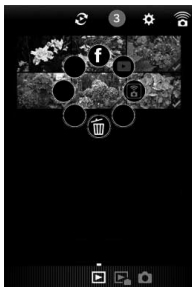

## 5

### Sharing

#### Memo

- When you touch and hold the desired image on the image list display screen or the shooting information display screen, the same screen as Step 4 appears and the desired action can be selected.

## Changing the Settings

### 1 Tap .



The [Settings] screen appears.

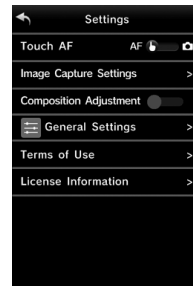

The following settings are available.

<b>Touch AF</b>	Sets whether to perform only autofocus or perform shooting after autofocus when touching the Live View image.
<b>Image Capture Settings</b>	Changes the settings for File Format and JPEG Recorded Pixels.
<b>Composition Adjustment</b>	Turns the composition adjustment function on or off.
<b>General Settings</b>	Changes the communication settings and the display language.

2 Tap [General Settings] to change the communication settings and the display language.

3 Tap the setting item to change.

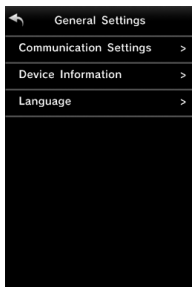

**Communication Settings**  
The password and wireless channel can be changed.

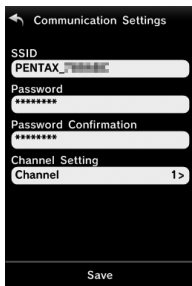

Device Information

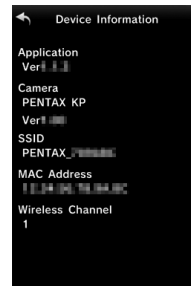

Language

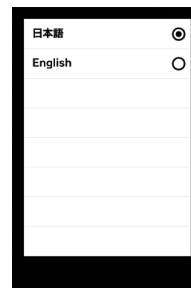

4 Change the settings and tap ↩.

# Camera Settings

## Customizing the Button/E-dial Functions



### Setting the Button Operation

You can set the functions for when **Fx1**, **Fx2**, **Fx3**, or **AF/AE-L** is pressed.

In **AF** mode, you can set only the function for when **AF/AE-L** is pressed.

**1** Select **[Button Customization]** in the **5** or **2** menu and press **▶**.

The **[Button Customization]** screen appears.

**2** Select the desired item and press **▶**.

The screen to set the function for the selected item is displayed.



**3** Press **▶** and use **▲▼** to select the function to assign to each part.

	Setting	Function	Page
Fx1 Button Fx2 Button Fx3 Button	<b>EV Compensation</b>	Sets the exposure compensation value (assigned to <b>Fx3</b> by default).	p.56
	<b>Sensitivity</b>	Sets the ISO sensitivity.	p.55
	<b>Preview</b>	Displays the preview image to check the composition, exposure, and focus before shooting.	p.104
	<b>AE Lock</b>	Locks the exposure settings.	p.51
	<b>Change AF Area</b>	Switches the function of the arrow keys to AF area change mode or direct key operation mode.	p.61, p.63
	<b>One Push File Format</b>	Temporarily changes the file format (assigned to <b>Fx1</b> by default).	p.103
	<b>Electronic Level</b>	Turns the Electronic Level display for the viewfinder and Live View on or off (assigned to <b>Fx2</b> by default).	p.20
	<b>Wi-Fi *1</b>	Turns the Wi-Fi™ function on or off.	p.94
	<b>Night Vision LCD Display *1</b>	Turns the Night Vision LCD Display feature on or off.	p.122
	<b>Operation Control Lock</b>	Enables or disables the Operation Control Lock feature.	p.51



	Setting	Function	Page
AF/AE-L Button	Enable AF1	Autofocus is performed when <b>AF/AE-L</b> is pressed.	p.59
	Enable AF2	Autofocus is performed when <b>AF/AE-L</b> is pressed. Half press of <b>SHUTTER</b> is disabled.	
	Cancel AF	While <b>AF/AE-L</b> is pressed, half press of <b>SHUTTER</b> is disabled.	
	AE Lock	Locks the exposure settings.	p.51

\*1 Available only when [Fx1 Button] is selected.

**4** Press **OK**.

**5** Press **MENU**.

The screen of Step 2 reappears.  
Repeat Steps 2 to 5.

**6** Press **MENU** twice.

### Memo

- You can check the functions assigned to the buttons while the Guide Display feature is active (p.27). When the following functions are assigned to **Fx1**, **Fx2**, or **Fx3**, the function name and current setting are displayed after the button is pressed.
  - One Push File Format
  - Electronic Level
  - Wi-Fi
  - Night Vision LCD Display
- You can assign the same function to **Fx1**, **Fx2**, and **Fx3**.
- When [Change AF Area], [One Push File Format], [Electronic Level], [Wi-Fi], or [Night Vision LCD Display] is assigned to **Fx1**, **Fx2**, or **Fx3**, pressing the button makes a beep sound. To disable the beep sound, change the sound setting for each function in [Sound Effects] of the  1 menu. (p.32)
- When [Operation Control Lock] is assigned to **Fx1**, **Fx2**, or **Fx3** and is enabled, the restrictions on the use of buttons and dials are canceled if another function is assigned to the button.

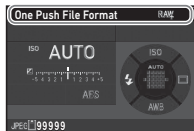

## Setting the One Push File Format

You can temporarily change the file format by pressing the button during shooting. By default, [One Push File Format] is assigned to **Fx1**.

**1** Set [One Push File Format] to [Fx1 Button], [Fx2 Button], or [Fx3 Button] in Step 3 of “Setting the Button Operation” (p.102).

**2** Select  or  for [Cancel after 1 shot].

<input checked="" type="checkbox"/>	The recording format returns to the [File Format] setting of [Image Capture Settings] in the  2 menu after a picture is taken.
<input type="checkbox"/>	The setting is retained until any of the following operations is performed: <ul style="list-style-type: none"> <li>When <b>Fx1</b>, <b>Fx2</b>, or <b>Fx3</b> is pressed again</li> <li>When <b>Q</b>, <b>MENU</b>, or <b>INFO</b> is pressed, or when the mode dial or main switch is turned</li> </ul>

**3** Select the file format when the button is pressed.

The left side is the [File Format] setting and the right side is the changed file format when the button is pressed.

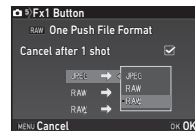

**4** Press **MENU** three times.

The camera returns to standby mode.

### Memo



- When the button is pressed and held, a beep sounds and the One Push File Format is enabled.

## Setting the Preview

You can display the preview image by pressing the button before shooting.

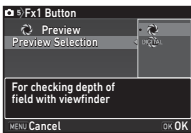
- 1 Set [Preview] to [F<sub>x</sub>1 Button], [F<sub>x</sub>2 Button], or [F<sub>x</sub>3 Button] in Step 3 of “Setting the Button Operation” (p.102).
- 2 Select a preview method in [Preview Selection] and press **OK**.



 <b>Optical Preview</b>	Activates the Optical Preview function to check the depth of field with the viewfinder.
 <b>Digital Preview</b>	Activates the Digital Preview function to check the composition, exposure, and focus on the monitor. Zoom Review, Save Preview Image, Histogram Display, and Highlight Alert are available.

Proceed to Step 4 when  is selected.

- 3 Press **▼** and select  or  for each display item.

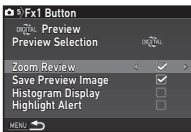

- 4 Press **MENU** three times.  
The camera returns to standby mode.

## Memo

- Optical Preview is always used in the following situations regardless of the setting.
  - When the drive mode is set to [Mirror Lock-up Shooting], [Multi-exposure], or [Interval Shooting]
  - In  mode

## Caution

- The effects of some functions cannot be checked during Digital Preview or are not applied to the saved preview image.

## Setting the Smart Function

Some useful functions can be assigned to C1, C2, and C3 of the function dial, and the setting values can be changed with the setting dial. (p.21)

### 1 Select [Button Customization] in the 5 menu and press .

The [Button Customization] screen appears.

### 2 Turn and select [Function Dial], and press .

The [Function Dial] screen appears.

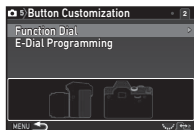

### 3 Select [C1], [C2], or [C3], and press .

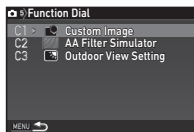

### 4 Use to select the function to save.

Setting	Function	Page
<b>Sensitivity</b>	Changes the ISO sensitivity.	p.54
<b>EV Compensation</b>	Changes the exposure compensation value.	p.56
<b>Bracket Value</b>	Changes the bracket value for Bracketing.	p.66
<b>Custom Image</b>	Changes the image finishing tone for Custom Image (assigned to C1 by default).	p.74
<b>AF Mode</b>	Changes the autofocus mode.	p.60, p.62
<b>AF Active Area</b>	Changes the focusing area selection mode.	p.60, p.62

Setting	Function	Page
<b>Focus Peaking</b>	Changes the Focus Peaking setting.	p.61
<b>Program Line</b>	Changes the Program Line setting.	p.50
<b>Shutter Mode Selection</b>	Switches between the mechanical shutter and the electronic shutter.	p.52
<b>Recorded Pixels</b>	Changes the number of recorded pixels of an image or movie.	p.48
<b>AA Filter Simulator</b>	Changes the capture type of AA Filter Simulator (assigned to C2 by default).	p.79
<b>Grid Display</b>	Changes the type of the grid lines displayed during Live View or playback.	p.46, p.47
<b>LCD Display Options</b>	Changes the type of information displayed during shooting or playback.	p.16, p.17
<b>Image Magnification</b>	Magnifies the image when shooting with Live View or during playback.	p.46, p.47
<b>Outdoor View Setting</b>	Changes the brightness of the monitor (assigned to C3 by default).	p.108

### 5 Press .

The [Function Dial] screen reappears. Repeat Steps 3 to 5.

### 6 Press three times.

**Memo**

- The assigned functions can be checked on the status screen or Live View screen when the function dial or setting dial is turned.

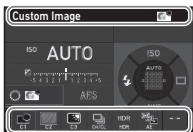

**Setting the E-dial Operation**

For each exposure mode, you can set the functions for when and are turned and is pressed. The function can be set for exposure modes other than **B** mode.

- 1** Select **[Button Customization]** in the 5 or 2 menu and press .

The [Button Customization] screen appears.

- 2** Turn and select **[E-Dial Programming]**, and press .

The [E-Dial Programming] screen appears.

- 3** Select an exposure mode and press .

The screen for the selected exposure mode appears.

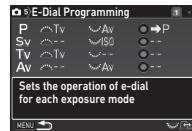

- 4** Press and use to select the combination of functions for when and are turned and is pressed.

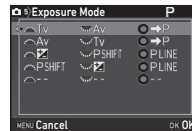

<b>Tv</b>	Change Shutter Speed
<b>Av</b>	Change Aperture Value
<b>ISO</b>	Change Sensitivity
	EV Compensation
<b>P</b>	Return to <b>P</b> Mode
<b>PSHIFT</b>	Program Shift
<b>PLINE</b>	Program Line
--	Not available





- 5** Press .

## 6 Press **MENU**.

The [E-Dial Programming] screen reappears.  
Repeat Steps 3 to 6.

## 7 Press **MENU** three times.

### **Memo**

- If you select [Rotation Direction] in Step 3, you can reverse the effect obtained by turning  or .
- You can check the functions assigned to , , and  while the Guide Display (p.45) is shown.

## Setting the Monitor and Indicator Lamps



### Adjusting the Brightness, Saturation, and Color of the Monitor

You can set the brightness, saturation, and color adjustment of the monitor.



#### 1 Select [LCD Display Settings] in the 2 menu and press **▶**.

The [LCD Display Settings] screen appears.

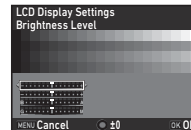
#### 2 Adjust the brightness, saturation, and color.



#### Available operations

- 
-  Selects a parameter.
- 
-  Adjusts the value.
- 
-  Resets the adjustment value to the default setting.
- 

#### 3 Press **OK**.

The 2 menu reappears.

### **Caution**

- When [Outdoor View Setting] is set, [LCD Display Settings] cannot be changed.

## Adjusting the Brightness of the Monitor for Outdoor Shooting

If the monitor display is difficult to see when you take pictures outdoors or in other situations, adjust the brightness of the monitor in [Outdoor View Setting] of the 2 menu.

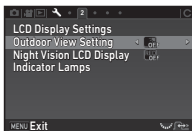

### Memo

- When [Outdoor View Setting] is assigned to the function dial, you can change the setting using the Smart Function. (p.21, p.105) By default, [Outdoor View Setting] is assigned to C3.

## Setting the Lighting-up of the Indicator Lamps

You can set whether to light up each indicator lamp in [Indicator Lamps] of the 2 menu.

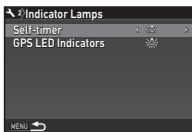

## Saving Frequently Used Settings





Four factory preset settings—HDR LANDSCAPE, MACRO, ASTROPHOTO, and MANUAL LENS—are assigned to **U1** to **U4** of the mode dial.

You can save frequently used camera settings to **U1** to **U5** by replacing the preset settings with them.

The following settings can be saved.

Exposure Mode	Drive Mode
Sensitivity	White Balance
EV Compensation	 menu and <b>C</b> menu settings (with exceptions)
Flash Mode	

## Saving the Settings

- Set the exposure mode and all the necessary settings to save.
- Select [Save USER Mode] in the 5 menu and press . The [Save USER Mode] screen appears.
- Select [Save Settings] and press . The [Save Settings] screen appears.
- Select a USER mode from [USER1] to [USER5], and press .
- Select [Save] and press **OK**.
- Press **MENU**. The screen of Step 3 reappears.

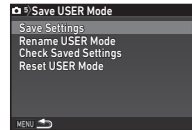

### Caution

- [Save USER Mode] cannot be selected when the mode dial is set to **AUTO** or in  mode.

## Memo

- The settings saved as the USER mode can be displayed on the monitor when you select [Check Saved Settings] in Step 3.
- To reset the saved settings to their default values, select [Reset USER Mode] in Step 3.

## Editing a Setting Name

You can change the name of the USER mode in which you saved settings.

### 1 Select [Rename USER Mode] in Step 3 of “Saving the Settings” (p.108) and press .

The [Rename USER Mode] screen appears.

### 2 Select a USER mode from [USER1] to [USER5], and press .

The text-entry screen appears.

### 3 Change the text.

Up to 18 single-byte alphanumeric characters and symbols can be entered.

Text selection cursor

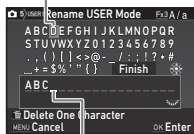

Text input cursor

#### Available operations



Moves the text selection cursor.



Moves the text input cursor.



Switches between upper and lower case letters.



Enters a character selected with the text selection cursor at the position of the text input cursor.





Deletes a character at the position of the text input cursor.

### 4 After entering the text, move the text selection cursor to [Finish], and press **OK**.

The [Rename USER Mode] screen reappears.

## Using the Saved USER Mode

### 1 Set the mode dial to U1 to U5.

The USER mode name is displayed as the guide display. Use   to check the saved settings.



### 2 Change the settings as necessary.

The exposure mode can be changed in [Exposure Mode] of the 1 menu.

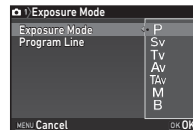

## Memo

- The settings changed in Step 2 are not saved as the USER mode settings. When the camera is turned off, the camera returns to the saved USER settings. To change the saved settings, save the USER mode settings again.

## Selecting Settings to Save in the Camera



The setting values for most functions of this camera are saved even if the camera is turned off. For the following function settings, you can select whether to save the settings (☑) or to return the settings to their default values (☐) when the camera is turned off.

Set in [Memory] of the 5 menu.

<b>Sensitivity</b>	<b>Digital Filter</b>
<b>EV Compensation</b>	<b>HDR Capture</b>
<b>Flash Mode</b>	<b>Pixel Shift Resolution</b>
<b>Flash Exposure Compensation</b>	<b>Composition Adjust.</b>
<b>Drive Mode</b>	<b>Shooting Info Display</b>
<b>White Balance</b>	<b>Playback Info Display</b>
<b>Custom Image</b>	<b>Outdoor View Setting</b>
<b>Clarity</b>	<b>Night Vision LCD Display</b>
<b>Skin Tone</b>	<b>Operation Control Lock</b>

### Memo

- When [Reset] of the 5 menu is performed, all Memory settings return to the default values.

## File Management Settings

### Protecting Images from Deletion

You can protect images from being accidentally deleted.

#### Caution

- Even protected images are deleted if the inserted memory card is formatted.

#### 1 Select [Protect] in the playback mode palette.

The screen for selecting the processing type appears.

#### 2 Select [Select image(s)] or [Select a folder] and press .



#### 3 Select the image(s) or folder to protect.

Proceed to Step 5 if [Select a folder] is selected.

How to select image(s) (p.82)

#### 4 Press .

The confirmation screen appears.

#### 5 Select [Protect] and press .

#### Memo

- To protect all images stored on the memory card, select [Protect All Images] of the 1 menu.



## Create New Folder

When [Create New Folder] is selected in the 4 menu, a folder is created with a new number when the next image is saved.

### ⚠ Caution

- You cannot successively create multiple folders.

### 📝 Memo

- A new folder is automatically created in the following cases.
  - When the drive mode is set to [Interval Shooting] (p.70)
  - When [Select multiple images] or [Select a folder] is selected for [RAW Development] of the playback mode palette (p.90)

## Folder Name

When images are captured with this camera, a folder is automatically created and the captured images are stored in it. Each folder name consists of a sequential number from 100 to 999 and a string of 5 characters.

The character string in the folder name can be changed.

### 1 Select [Folder Name] in the 4 menu and press .

The [Folder Name] screen appears.

### 2 Press and select [Date] or [Optional].

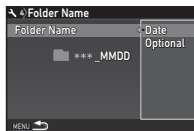

<b>Date</b>	The four digits of the month and day of the shooting date are assigned after the folder number. The month and day appear according to the [Date Format] setting in [Date Adjustment] of the  1 menu. Example) 101_0125: for images taken on January 25th
<b>Optional</b>	A freely defined string of five characters is assigned after the folder number. (Default setting: PENTX) Example) 101PENTX

Proceed to Step 6 if you select [Date] or do not need to change the character string.

### 3 Press , and then press .

The text-entry screen appears.

### 4 Change the text.

Enter five single-byte alphanumeric characters.

Text selection cursor

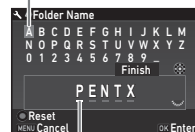

Text input cursor

### Available operations

- Moves the text selection cursor.
- Moves the text input cursor.
- OK** Enters a character selected with the text selection cursor at the position of the text input cursor.
- O** Resets the entered text to "PENTX".

### 5 After entering the text, move the text selection cursor to [Finish], and press **OK**.

### 6 Press **MENU** twice.

### 📌 Memo

- A folder with a new number is created when the folder name is changed.
- A maximum of 500 images can be stored in a single folder. When the number of captured images exceeds 500, a new folder is created with the number following the number of the folder currently being used. When the drive mode is set to [Bracketing], images are stored in the same folder until shooting is completed.

### ⚠️ Caution

- The maximum folder number is 999. After the folder number reaches 999, you cannot capture new images if you attempt to change the folder name or create a new folder, or when the file name number reaches 9999.

## File Name

One of the following string of characters is used as the file name prefix depending on the [Color Space] setting of [Image Capture Settings] in the 2 menu.

Color Space	File Name
sRGB	IMGP****.JPG
AdobeRGB	_IMG****.JPG

The first four characters can be changed to a character string of your choice.

### 1 Select [File Name] in the 4 menu and press .

The [File Name] screen appears.

### 2 Select or , and press .

The text-entry screen appears.

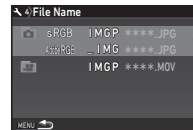

### 3 Change the text.

Up to four single-byte alphanumeric characters can be entered as an alternative for the first part of the file name, while the asterisks stand for figures that increase automatically shot by shot.

How to enter text (p.111)

### 4 Press **MENU** twice.

#### 📌 Memo

- When [Color Space] is set to [AdobeRGB], the file name prefix is “\_” and first three characters of the entered character string become the file name.
- For movies, regardless of the [Color Space] setting, the file name is “IMG P\*\*\*\*.MOV” or the one with the entered string of characters.

## File No.

Each file name consists of a string of four characters and a sequential number from 0001 to 9999. You can set whether to continue the sequential numbering for the file name even if a new folder is created in [Sequential Numbering] of [File No.] in the **4** menu.

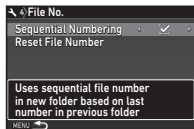

<input checked="" type="checkbox"/>	Continues the sequential numbering for the file name even if a new folder is created.
<input type="checkbox"/>	Returns the file number of the first image saved to a folder to 0001 each time a new folder is created.

Select [Reset File Number] to reset the file number to its default value.

### **Memo**

- When the file number reaches 9999, a new folder is created and the file number is reset.

## Setting the Copyright Information



You can set the photographer and copyright information embedded in the Exif data.

### 1 Select [Copyright Information] in the **4** menu and press **▶**.

The [Copyright Information] screen appears.

### 2 Use **◀▶** to set [Embed Copyright Data].



<input type="checkbox"/>	Does not embed copyright information in the Exif data.
<input checked="" type="checkbox"/>	Embeds copyright information in the Exif data.

### 3 Select [Photographer] or [Copyright Holder], and press **▶**.

The text-entry screen appears.

### 4 Change the text.

Up to 32 single-byte alphanumeric characters and symbols can be entered.

How to enter text (p.109)

### 5 Press **MENU** twice.

### **Memo**

- The Exif information can be checked in Detailed Information Display of the playback mode (p.17) or using the provided software "Digital Camera Utility 5".

## Displaying the Local Date and Time of the Specified City



The date and time set at the time of initial setting ("Initial Settings" (p.42)) serve as the date and time of your present location and are reflected in the shooting date and time for images.

Setting the destination to a location other than your present location enables you to display the local date and time on the monitor when traveling abroad and also save images time-stamped with the local date and time.

### 1 Select [World Time] in the 1 menu.

The [World Time] screen appears.

### 2 Select the time you wish to display in [Time Setting].

(Hometown) or (Destination) can be selected.

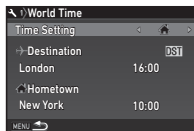

### 3 Select [ Destination] and press .

The [ Destination] screen appears.

### 4 Use to select a city.

Use to change the region.

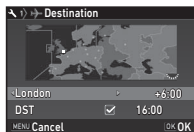

### 5 Select [DST] (daylight saving time), and use to select or .

### 6 Press **OK**.

The screen of Step 2 reappears.

### 7 Press **MENU** twice.

## Memo

- Refer to "List of World Time Cities" (p.131) for cities that can be selected as a hometown or destination.
- Select [ Hometown] in Step 3 to change the city and DST settings for the hometown.
- and the local date and time appear in the control panel when [Time Setting] is set to .

# Restrictions on the Combinations of Special Functions

#: Restricted X: Not available

	Electronic Shutter	Clarity/Skin Tone/Digital Filter	HDR Capture	Pixel Shift Resolution	ASTRO-TRACER	AA Filter Simulator	Distortion Correction/Diffraction Correction	Save RAW Data	
Flash	X		X	X					
Drive Mode	Continuous Shooting		X	X	X	#*3		X	
	Bracketing/Depth of Field Bracketing/Motion Bracketing		X	X	X	#*3		#*4	
	Mirror Lock-up Shooting		X			#*3			
	Multi-exposure		X	X	X	#*3	X		
	Interval Shooting	X	#*1	#*1	X	#*2	#*3	#*4	
	Interval Composite	X	X	X	X	X	#*3	X	#*4
	Interval Movie Record	X	#*1	#*1	X	#*2	#*3	X	
	Star Stream	X	X	X	X	X	#*3	X	X
HDR Capture	X	X		X	X	X			
Pixel Shift Resolution		X	X		X	X			
AA Filter Simulator	X		X	X	#*3				

\*1 There is a restriction on the minimum value for [Interval].

\*2 Only when the timed exposure is set.

\*3 [Bracketing] is not available.

\*4 Only the final frame can be saved.

## Functions Available with Various Lenses

All capture modes are available when a DA, DA L, D FA, FA J, or FA lens is used, or when a lens with an **A** position is used with the aperture ring set to the **A** position.

Depending on the lens to use, the following restrictions apply.

✓ : Available # : Restricted ✗ : Not available

Function \ Lens [Mount type]	DA	DA L	D FA	FA J FA <sup>*6</sup>	F <sup>*6</sup>	A	M P
	[KAF] [KAF2] [KAF3] [KAF4]	[KAF] [KAF2]	[KAF] [KAF2]	[KAF]	[KA]	[K]	
Autofocus (Lens only) (With AF adapter 1.7×) <sup>*1</sup>	✓ -	✓ -	✓ -	✓ -	✓ -	- #	- #
Manual focus (With focus indicator) <sup>*2</sup> (With matte field)	✓	✓	✓	✓	✓	✓	✓
Quick-shift focus	# <sup>*4</sup>	✗	✗	✗	✗	✗	✗
AF Active Area [Auto]	✓	✓	✓	✓	# <sup>*6</sup>	✗	✗
AE Metering [Multi-segment]	✓	✓	✓	✓	✓	✓	✗
<b>P/Sv/Tv/Av/TA</b> v mode	✓	✓	✓	✓	✓	✓	# <sup>*9</sup>
<b>M</b> mode	✓	✓	✓	✓	✓	✓	#
P-TTL auto flash <sup>*3</sup>	✓	✓	✓	✓	✓	✓	✗
Automatic obtaining of the lens focal length information	✓	✓	✓	✓	✓	✗	✗
Lens Correction	# <sup>*5</sup>	# <sup>*7</sup>	✗	✗	✗	✗	✗

<sup>\*1</sup> Lenses with a maximum aperture of F2.8 or faster. Only available at the **A** position.

<sup>\*2</sup> Lenses with a maximum aperture of F5.6 or faster.

<sup>\*3</sup> Available when using the built-in flash, AF540FGZ, AF540FGZ II, AF360FGZ, AF360FGZ II, AF201FG, AF200FG, or AF160FC.

<sup>\*4</sup> Only available with compatible lenses.

<sup>\*5</sup> Distortion Correction and Peripheral Illumination Correction are disabled when a DA FISH-EYE 10-17mm lens is used.

<sup>\*6</sup> To use an FA SOFT 28mm F2.8 lens, FA SOFT 85mm F2.8 lens, or F SOFT 85mm F2.8 lens, set [24 Using Aperture Ring] to [Enable] in the **C4** menu. Pictures can be taken with the aperture you set, but only within a manually adjustable aperture range.

<sup>\*7</sup> The Lens Correction features are available with the following FA lenses (Only Distortion Correction and Lateral Chromatic Aberration Adjustment can be used when the aperture ring is set to a position other than **A**.): FA<sup>\*</sup>24mm F2 AL [IF], FA 28mm F2.8 AL, FA 31mm F1.8 Limited, FA 35mm F2 AL, FA 43mm F1.9 Limited, FA 50mm F1.4, FA 77mm F1.8 Limited, FA<sup>\*</sup>85mm F1.4 [IF], FA<sup>\*</sup>200mm F2.8 ED [IF], FA<sup>\*</sup>MACRO 200mm F4 ED, FA<sup>\*</sup>300mm F2.8 ED [IF], FA<sup>\*</sup>300mm F4.5 ED [IF], FA<sup>\*</sup>400mm F5.6 ED [IF], FA<sup>\*</sup>600mm F4 ED [IF], FA<sup>\*</sup>28-70mm F2.8 ED [IF], FA<sup>\*</sup>80-200mm F2.8 ED [IF], and FA<sup>\*</sup>250-600mm F5.6 ED [IF].

<sup>\*8</sup> Fixed to [Spot].

<sup>\*9</sup> **Av** with the aperture set to wide open. (The aperture ring has no effect on the actual aperture value.)

### ● Caution

- When the aperture ring is set to a position other than **A** or a lens without an **A** position or accessories such as an extension tube are used, the camera does not operate unless [24 Using Aperture Ring] is set to [Enable] in the **C4** menu. Refer to "Using the Aperture Ring" (p.118) for details.
- When a retractable lens is attached and is not extended, you cannot take pictures or use some functions. If the lens is retracted during shooting, the camera stops working.

### About Mount Names

DA and D FA lenses with a motor and FA zoom lenses with a power zoom use the KAF2 mount. (Of these lenses, the lenses without an AF coupler use the KAF3 mount.)

The KAF3 mount equipped with an electromagnetic diaphragm mechanism instead of an aperture control lever is referred to as the KAF4 mount.

FA single focal length lenses (non-zoom lenses), DA and DA L lenses without a motor, and D FA, FA J, and F lenses use the KAF mount. (The power zoom function is not compatible with this camera.)

Refer to respective lens manuals for details.

## Compatibility with the Built-in Flash

Depending on the lens being used, the use of the built-in flash may be limited.

(As of December 2016)

Lens	Restrictions when using the built-in flash
<b>DA FISH-EYE 10-17mm F3.5-4.5 ED [IF]/</b> <b>DA 12-24mm F4 ED AL/</b> <b>DA 14mm F2.8 ED [IF]/</b> <b>DA 15mm F4 ED AL/</b> <b>D FA 15-30mm F2.8 ED SDM WR/</b> <b>FA★300mm F2.8 ED [IF]/</b> <b>DA 560mm F5.6 ED AW/</b> <b>FA★600mm F4 ED [IF]/</b> <b>FA★250-600mm F5.6 ED [IF]</b>	The built-in flash is not available due to vignetting.
<b>F FISH-EYE 17-28mm F3.5-4.5</b>	Vignetting may occur if the focal length is less than 20 mm.
<b>DA 16-45mm F4 ED AL</b>	When the focal length is less than 28 mm, or when the focal length is 28 mm and the shooting distance is 1 m or less, vignetting may occur.
<b>DA★16-50mm F2.8 ED AL [IF] SDM</b>	When the focal length is 20 mm or less, or when the focal length is 35 mm and the shooting distance is less than 1.5 m, vignetting may occur.
<b>DA 16-85mm F3.5-5.6 ED DC WR</b>	When the focal length is 24 mm or less and the shooting distance is 0.8 m or less, vignetting may occur.
<b>DA 17-70mm F4 AL [IF] SDM</b>	When the focal length is less than 24 mm, or when the focal length is 35 mm and the shooting distance is 1 m or less, vignetting may occur.

Lens	Restrictions when using the built-in flash
<b>DA 18-250mm F3.5-6.3 ED AL [IF]</b>	Vignetting may occur if the focal length is less than 35 mm.
<b>DA 18-270mm F3.5-6.3 ED SDM</b>	Vignetting may occur if the focal length is less than 24 mm.
<b>D FA 24-70mm F2.8 ED SDM WR</b>	Vignetting may occur if the focal length is less than 36 mm.
<b>FA★28-70mm F2.8 AL</b>	Vignetting may occur if the focal length is 28 mm and the shooting distance is less than 1 m.
<b>FA SOFT 28mm F2.8/</b> <b>FA SOFT 85mm F2.8</b>	The built-in flash always discharges fully.

## Using the Aperture Ring

C4

The shutter can be released even if the aperture ring of the D FA, FA, F, or A lens is not set to the **A** position or a lens without an **A** position is attached.

Select [Enable] in [24 Using Aperture Ring] of the **C4** menu.

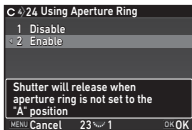

The following restrictions apply depending on the lens being used.

Lens	Restriction
D FA, FA, F, A, M (lens only or with automatic diaphragm accessories such as Auto Extension Tube K)	The aperture remains open. <sup>*1</sup> The shutter speed changes in relation to the open aperture but an exposure deviation may occur.
D FA, FA, F, A, M, S (with diaphragm accessories such as Extension Tube K) Manual diaphragm lens such as reflex lens (lens only)	Pictures can be taken with the set aperture value but an exposure deviation may occur.
FA SOFT 28mm/ FA SOFT 85mm/ F SOFT 85mm (lens only)	Pictures can be taken with the set aperture value within a manually adjustable aperture range. <sup>*1</sup>

<sup>\*1</sup> When the mode dial is set to **M** or **B**, the aperture can be stopped down to the selected value.

### Memo

- If the aperture ring is set to a position other than **A**, the camera operates in **Av** mode regardless of the mode dial setting except when set to **M** or **B** mode.
- [F--] appears for the aperture indicator in the status screen, Live View screen, and viewfinder.

## How to Achieve the Correct Exposure with the Aperture Ring Not Set to A

The correct exposure can be achieved by the following procedures when the aperture ring is not set to **A**.

- 1 Set the mode dial to **M**.
- 2 Set the aperture ring to the desired aperture.
- 3 Press **○**.  
The correct shutter speed will be set.
- 4 If the correct exposure cannot be achieved, adjust the ISO sensitivity.



You can perform Catch-in Focus shooting using a manual focus lens. The shutter is released automatically when the subject comes into focus.

- 1 **Attach a manual focus lens to this camera.**
- 2 **Set [22 Catch-in Focus] to [On] in the C4 menu.**
- 3 **Set the AF/MF switch to AF and set [AF Mode] to AFS.**
- 4 **Place the camera on a fixed support such as a tripod.**
- 5 **Adjust the focus to the position where the subject may pass and press **SHUTTER** fully.**  
When the subject comes into focus at the specified position, the shutter is released automatically.

The Shake Reduction function operates by obtaining the lens information such as focal length. Set the focal length when using a lens that the focal length information cannot be automatically obtained.

- 1 **Set [24 Using Aperture Ring] to [Enable] in the C4 menu.**
- 2 **Turn the camera off.**
- 3 **Attach a lens to the camera and turn the camera on.**  
The [Input Focal Length] screen appears.
- 4 **Use ▲▼ to set the focal length.**  
Press ◀ to select a value from the list.  
When using a zoom lens, select the actual focal length which the zoom is set to.

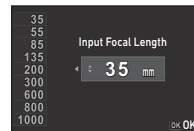

- 5 **Press **OK**.**  
The camera returns to standby mode.

#### **Memo**

- The focal length setting can be changed in [Input Focal Length] of the  C4 menu.

## Functions when Using an External Flash

Use of the following external flashes (optional) enables a variety of flash modes, such as P-TTL auto flash mode.

✓ : Available # : Restricted ✗ : Not available

Compatible Flash Camera Function	Built-in Flash	AF540FGZ AF540FGZ II AF360FGZ AF360FGZ II	AF201FG AF200FG AF160FC
Red-eye reduction flash	✓	✓	✓
Auto Flash Discharge *1	✓	✓	✓
Automatic switch to flash sync speed	✓	✓	✓
Automatic setting of the aperture value in <b>P</b> or <b>Tv</b> mode	✓	✓	✓
P-TTL auto flash	#*2	#*2	#*2
Slow-speed Sync flash	✓	✓	✓
Flash Exposure Compensation	✓	✓	✓
AF assist light of the external flash	✗	#*3	✗
Trailing Curtain Sync flash *4	✓	✓	#*5
Contrast Control Sync flash	#*6	✓	#*7
Slave flash	✗	✓	✗
High-speed Sync flash	✗	✓	✗
Wireless flash	#*7	#*7	✗

\*1 Only the **AUTO** mode is available for the capture mode.

\*2 Available only when using a DA, DA L, D FA, FA J, FA, F, or A lens. (When using a lens with an aperture ring, set the aperture ring to the **A** position.)

\*3 AF assist light is not available with the AF540FGZ or AF360FGZ.

\*4 Shutter speed of 1/90 seconds or slower.

\*5 Available with the AF201FG.

\*6 Available only when combined with the AF540FGZ, AF540FGZ II, AF360FGZ, or AF360FGZ II (two or more compatible external flashes for Contrast Control Sync flash required).

\*7 Available only when combined with the AF540FGZ, AF540FGZ II, AF360FGZ, or AF360FGZ II.

### ⚠ Caution



- Never press  on the camera when any external flash unit is attached to the camera. The built-in flash will hit the external flash. If you want to use both at once, connect them using an extension cord.
- Flashes with the reversed polarity (the center contact on the hot shoe is minus) cannot be used due to the risk of damaging the camera and flash.
- Do not combine with accessories that have a different number of contacts, such as Hot Shoe Grip, as a malfunction may occur.
- Combining with flashes from other manufacturers may cause equipment breakdown.

### 📌 Memo

- With the AF540FGZ, AF540FGZ II, AF360FGZ, or AF360FGZ II, you can use the high-speed sync flash to discharge a flash and take a picture at a shutter speed faster than 1/180 seconds. Set the capture mode to **Tv**, **TAv**, or **M**.
- By using two or more external flashes (AF540FGZ, AF540FGZ II, AF360FGZ, or AF360FGZ II) or by using these external flashes in combination with the built-in flash, you can use the wireless mode (controller flash) to shoot in P-TTL flash mode without connecting the flash units with a cord. In this case, set the camera channel on the external flashes. You can check the set channel in the status screen, Live View screen, and viewfinder. (p.14, p.19)

## Using the GPS Unit

When the optional GPS unit O-GPS1 is attached to the camera, GPS information is saved in the shooting information of an image, and furthermore, the following functions are available.

<b>Electronic Compass</b>	Displays the current latitude, longitude, altitude, direction, Coordinated Universal Time (UTC), capture mode, and exposure value. Select [Electronic Compass] in "Shooting Info Display" (p.16).	
<b>ASTRO-TRACER</b>	Tracks and captures celestial bodies. By matching the movement of the camera's built-in Shake Reduction unit with the movement of celestial bodies, celestial bodies can be captured as individual points even when shooting with a long exposure setting. (p.121)	
<b>GPS Time Sync</b>	Automatically adjusts the camera's date and time settings using information obtained from GPS satellites. Set in [GPS/E-Compass] of the  3 menu.	

### Memo



- Refer to the manual of the GPS unit for details on how to attach the unit and information on the unit's functions.

### Caution

- "Simple Navigation" cannot be used with this camera.

## Shooting Celestial Bodies

### Setting the ASTROTRACER

- 1 Attach the GPS unit to the camera and turn the camera on.
- 2 Select [ASTROTRACER] in the  3 menu and press .  
The [ASTROTRACER] screen appears.

- 3 Select [ASTROTRACER] and press .

- 4 Select [On] and press .

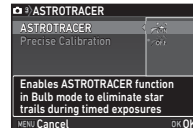

- 5 Select [Precise Calibration] and press .  
The [Precise Calibration] screen appears.

- 6 Rotate the camera according to the instruction displayed on the monitor.  
The result of calibration appears.

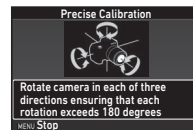

- 7 Press .  
The screen of Step 4 reappears.  
If [The operation could not be completed correctly] appears, change the camera direction and perform a calibration again.

- 8 Press  twice.  
The camera returns to standby mode.

## ⚠ Caution





- When performing a calibration, be careful not to drop the camera. Wrap the strap around your wrist or take other preventive measures.
- If the battery is removed, perform a calibration again after the battery is put back in.
- As the magnetic field environment varies depending on the shooting location, a precise calibration must be performed at each location when shooting images of celestial bodies with ASTROTRACER.
- Changing the lens or the angle of the monitor after performing a calibration may have some effect on the magnetic field environment. In this case, perform a calibration again.

## Shooting with the ASTROTRACER

- 1 Set the mode dial to **B** and set the focus method to **MF**.
- 2 Set the shooting conditions.



### Available operations

- |   |  |
|---|--|
|  | Enables/Disables the timed exposure.   |
|  | Changes the exposure time within the range from 10" to 5'00" when the timed exposure is enabled. |
|  | Changes the aperture value.  |
|  | Performs a precise calibration.  |

- 3 Adjust the focus and press **SHUTTER** fully. Shooting starts.
- 4 Press **SHUTTER** fully again. Shooting stops. When the timed exposure is enabled, shooting stops automatically after the set time has elapsed.

## ⚠ Caution

- This function cannot be used in some capture modes or in combination with some other functions. (p.115)

### When the Monitor is too Bright

For shooting in a dark place for a long period of time, you can change the monitor display color to red by setting [Night Vision LCD Display] to [On] in the 2 menu. When [Night Vision LCD Display] is assigned to **Fx1**, you can turn the Night Vision LCD Display feature on or off by a simple button operation. (p.102)

# Troubleshooting



## Memo

- In rare cases, the camera may not operate correctly due to causes such as static electricity, etc. This can be remedied by taking the battery out and putting it back in again. If the camera operates correctly, it does not require any repairs.

Problem	Cause	Remedy
The camera does not turn on.	The battery is not installed properly.	Check the orientation of the battery.
	The battery power is low.	Charge the battery.
The shutter cannot be released.	The built-in flash is being charged.	Wait until charging is finished.
	There is no available space on the memory card.	Insert a memory card with available space or delete unwanted images.
	Data is being processed.	Wait until processing is finished.
	The lens aperture ring is set to a position other than <b>A</b> .	Set the lens aperture ring to the ring <b>A</b> position or select [Enable] in [24 Using Aperture Ring] of the <b>C4</b> menu. (p.118)
	The autofocus mode is set to <b>AFS</b> and the subject is not in focus.	Set the focus method to <b>MF</b> and adjust focus manually.

Problem	Cause	Remedy
Autofocus does not work.	The subject is difficult to focus on.	<b>AF</b> cannot work well for low-contrast objects (the sky, white walls, etc.), dark colors, intricate designs, rapidly-moving objects, or scenery shot through a window or a net-like pattern. Lock the focus on another object located at the same distance as your subject, then aim at the target and take a picture. Alternatively, use <b>MF</b> .
	The subject is too close.	Move away from the subject and take a picture.
The focus cannot be locked.	[AF Active Area] of Live View is set to [Tracking].	Set [AF Active Area] to other than [Tracking]. (p.62)
The built-in flash does not discharge.	The flash mode is set to [Auto Flash Discharge].	When the flash mode is set to [Auto Flash Discharge], the flash does not discharge if the subject is bright. Change the flash mode. (p.57)
The camera is not recognized when it is connected to a computer.	The USB connection mode is set to [PTP].	Set [USB Connection] to [MSC] in the  3 menu. (p.92)
Dust or dirt particles appear in images.	The CMOS sensor is dirty or dusty.	Activate [Dust Removal] from the  5 menu. The Dust Removal function can be activated every time the camera is turned on and off. Refer to "Sensor Cleaning" (p.124) if the problem persists.
Pixel defects such as bright spots and dark spots appear in the image.	There are defective pixels in the CMOS sensor.	Activate [Pixel Mapping] from the  5 menu. It takes about 30 seconds to correct the defective pixels, so be sure to install a fully charged battery.

Raise the mirror up and open the shutter when cleaning the CMOS sensor with a blower.

- 1 Turn the camera off and remove the lens.**
- 2 Turn the camera on.**
- 3 Select [Sensor Cleaning] in the  5 menu and press .**  
The [Sensor Cleaning] screen appears.
- 4 Select [Mirror Up] and press .**  
The mirror rises up.
- 5 Clean the CMOS sensor with a blower.**
- 6 Turn the camera off.**  
The mirror automatically returns to its original position.

### Caution

- Never use a spray blower or a blower with a brush. The CMOS sensor may be damaged. Do not wipe the CMOS sensor with a cloth.
- Do not put the tip of the blower inside the lens mount area. If the power is turned off during cleaning, it may cause damage to the shutter, the CMOS sensor, and the mirror. Hold the camera with the lens mount down while cleaning the sensor so dust will fall away from the camera when the blower is used.
- When the battery level is low, the message [Not enough battery power remaining to clean sensor] is displayed on the monitor. Install a fully charged battery. If the battery capacity becomes low during cleaning, a warning beep will sound. In this case, stop cleaning immediately.

### Memo

- Please contact your nearest service center for professional cleaning as the CMOS sensor is a precision part.
- You can use the optional Image Sensor Cleaning Kit O-ICK1 when cleaning the CMOS sensor.

## Error Messages

Error Messages	Description
Memory card full	The memory card is full and no more images can be saved. Insert a new memory card or delete unwanted files.
No image	There are no images that can be played back on the memory card.
This image cannot be displayed	You are trying to play back an image in a format not supported by this camera. You may be able to play it back on a computer.
No card in the camera	There is no memory card inserted in the camera.
Memory card error	The memory card has a problem, and image capture and playback are impossible. You may be able to play back or recover the images on a computer.
Card is not formatted	The memory card you have inserted is unformatted or has been previously used on another device and is not compatible with this camera. Use the card after formatting it with this camera.
Card is locked	The write-protect switch on the memory card you have inserted is locked. (p.137)
Cannot use this card	A memory card not compatible with this camera is inserted.
This image cannot be magnified	You are trying to magnify an image that cannot be magnified.
This image is protected	You are trying to delete an image that is protected. Remove the protection from the image. (p.110)
Not enough battery power remaining to activate Pixel Mapping	These messages appear when you try to perform Pixel Mapping or Sensor Cleaning, or to update the firmware if the battery level is insufficient. Install a fully charged battery.
Not enough battery power remaining to clean sensor	
Not enough battery power remaining to update the firmware	
Unable to update firmware. There is a problem with the firmware update file	The firmware cannot be updated. The update file is damaged. Try downloading the update file again.

Error Messages	Description
Image folder cannot be created	The maximum folder number (999) is being used, and no more images can be saved. Insert a new memory card or format the card.
Unable to store image	The image could not be saved because of a memory card error.
The operation could not be completed correctly	The operation failed. Try the operation again.
No more images can be selected	You are trying to select more than the maximum number of images for the following functions. <ul style="list-style-type: none"> <li>• Select &amp; Delete</li> <li>• RAW Development</li> <li>• Protect</li> </ul>
No image can be processed	There are no images that can be processed using the Digital Filter or RAW Development function.
This image cannot be processed	This message appears when you try to perform Resize, Cropping, Digital Filter, Movie Edit, RAW Development, or Save as Manual WB for images captured with other cameras, or when you try to perform Resize or Cropping for minimum file size images.
This function is not available in the current mode	You are trying to set a function that is not available with the currently selected capture mode.
The camera will turn off to prevent damage from overheating	The camera will turn off because its internal temperature is too high. Leave the camera turned off until it has had time to cool down before turning on the camera again.
Shutter release is disabled. Ensure the zooming index on the lens is set to a position that permits shutter release	Pictures cannot be taken when a retractable lens is attached and is not extended. (p.46)

# Main Specifications

## Model Description

Type	TTL autofocus, auto-exposure SLR digital camera with a built-in retractable P-TTL flash
Lens Mount	PENTAX KAF2 bayonet mount (AF coupler, lens information contacts, K-mount with power contacts)
Usable Lenses	KAF4, KAF3, KAF2 (power zoom not compatible), KAF, KA mount lenses

## Image Capture Unit

Image Sensor	CMOS with a primary color filter, Size: 23.5 × 15.6 (mm)
Effective Pixels	Approx. 24.32 megapixels
Total Pixels	Approx. 24.96 megapixels
Dust Removal	Image sensor cleaning using ultrasonic vibrations "DR II"
Sensitivity (Standard Output)	ISO range: 100 to 819200 • EV steps can be set to 1 EV, 1/2 EV, or 1/3 EV
ISO AUTO Setting	ISO Range (Maximum), ISO Range (Minimum) ISO Sensitivity Options: AUTO, Tv Minimum Shutter Speed: AUTO (Slow, Standard, Fast), Tv (1/6000 to 30 seconds)
Image Stabilizer	Sensor-shift Shake Reduction (SR II)
AA Filter Simulator	Moiré reduction using the SR unit: Off, Type1, Type2, Bracketing (2 images), Bracketing (3 images)

## File Formats

Recording Formats	RAW (PEF/DNG), JPEG (Exif 2.3 compliant), DCF 2.0 compliant
Recorded Pixels	JPEG:  (24M: 6016×4000),  (14M: 4608×3072),  (6M: 3072×2048),  (2M: 1920×1280) RAW: 24M (6016×4000)
Quality Level	RAW (14bit): PEF, DNG JPEG: ★★★ (Best), ★★ (Better), ★ (Good) • RAW + JPEG simultaneously recordable
Color Space	sRGB, AdobeRGB
Storage Media	SD, SDHC*, and SDXC* memory cards * UHS-I compatible
Storage Folder	Folder Name: Date (100_1018, 101_1019...) or user-assigned name (default: PENTX)

Storage File	File Name: user-assigned name (default: IMG*****) File No.: Sequential Numbering, Reset
--------------	--

## Viewfinder

Type	Pentaprism Finder
Coverage (FOV)	Approx. 100%
Magnification	Approx. 0.95× (50mm F1.4 at infinity)
Eye-Relief Length	Approx. 20.5 mm (from the view window) Approx. 22.3 mm (from the center of lens)
Diopter Adjustment	Approx. -2.5 to +1.5 m <sup>-1</sup>
Focusing Screen	Interchangeable Natural-Bright-Matte III focusing screen

## Live View

Type	TTL method using the CMOS image sensor
Autofocusing System	AF Method: Contrast detection AF AF Active Area: Face Detection, Tracking, Multiple AF Points, Select, Spot Focus Peaking: Highlight Edge, Extract Edge, Off
Display	Field of view: approx. 100%. Magnified view (up to 16×), Grid Display (4×4 Grid, Golden Section, Scale, Square 1, Square 2, Grid Color: Black, White), Histogram Display, Highlight Alert, Composition Adjustment

## LCD Monitor

Type	Tiltable wide viewing angle TFT color LCD monitor featuring an air-gapless structure with a tempered-glass front panel
Size	3.0 inches (aspect ratio 3:2)
Dots	Approx. 921K dots
Adjustment	Brightness, saturation and colors adjustable
Outdoor View Setting	Adjustable ±2 steps
Night Vision LCD Display	On, Off



## White Balance

Type	TTL method using the CMOS image sensor
Preset Modes	Auto White Balance, Multi Auto White Balance, Daylight, Shade, Cloudy, Fluorescent Light (D: Daylight Color, N: Daylight White, W: Cool White, L: Warm White), Tungsten Light, CTE, Manual White Balance (up to 3 settings), Color Temperature (up to 3 settings), Copying the white balance settings of a captured image
Fine Adjustment	Adjustable $\pm 7$ steps on A-B axis and G-M axis

## Focus System

Type	TTL phase-matching autofocus system
Focus Sensor	SAFOX 11, 27 points (25 cross type focus points in the center)
Brightness Range	EV -3 to 18 (ISO100, at normal temperature)
AF Modes	Single AF (AFS), Continuous AF (AFC), Auto select AF (AFA)
Focusing Area Selection Modes	Auto (27 AF Points), Zone Select, Select, Expanded Area AF (S, M, L), Spot
AF Assist Light	Dedicated LED AF assist light

## Exposure Control

Type	TTL open-aperture metering using 86K pixel RGB sensor Metering modes: Multi-segment, Center-weighted, Spot
Metering Range	EV -3 to 20 (ISO100 at 50mm F1.4)
Capture Modes	Scene Analyze Auto, Program, Sensitivity Priority, Shutter Priority, Aperture Priority, Shutter & Aperture Priority, Manual, Bulb, USER1, USER2, USER3, USER4, USER5
EV Compensation	$\pm 5$ EV (1/3 EV steps or 1/2 EV steps can be selected)
AE Lock	Can be assigned to <b>[Fn1]</b> , <b>[Fn2]</b> , and <b>[Fn3]</b> in [Button Customization].

## Shutter

Type	Mechanical shutter (electronically controlled vertical-run focal plane shutter), Electronic shutter
Shutter Speed	[Mechanical shutter] Auto: 1/6000 to 30 seconds, Manual: 1/6000 to 30 seconds (1/3 EV steps or 1/2 EV steps), Bulb (timed exposure setting possible from 10 seconds to 20 minutes) [Electronic shutter] Auto: 1/24000 to 30 seconds, Manual: 1/24000 to 30 seconds (1/3 EV steps or 1/2 EV steps)

## Drive Modes

Mode Selection	Single frame, Continuous (H, M, L), Self-timer (12 sec., 2 sec., continuous), Bracketing <sup>1</sup> (2, 3, or 5 frames), Depth of Field Bracketing <sup>1</sup> (3 frames), Motion Bracketing <sup>1</sup> (3 frames), Mirror Lock-up Shooting, Multi-exposure <sup>2</sup> , Interval Shooting <sup>1</sup> , Interval Composite <sup>1</sup> , Interval Movie Record <sup>1</sup> , Star Stream <sup>1</sup> *1 Available with Self-timer *2 Available with Continuous Shooting or Self-timer • Depth of Field Bracketing is available in <b>Av</b> mode. • Motion Bracketing is available in <b>Tv</b> mode.
Continuous Shooting	Max. approx. 7.0 fps, JPEG ([L]: ★★★ at Continuous H): up to approx. 28 frames, RAW: up to approx. 8 frames, RAW+: up to approx. 7 frames Max. approx. 3.0 fps, JPEG ([L]: ★★★ at Continuous M): up to approx. 70 frames, RAW: up to approx. 15 frames, RAW+: up to approx. 10 frames Max. approx. 0.8 fps, JPEG ([L]: ★★★ at Continuous L): up to approx. 100 frames, RAW: up to approx. 100 frames, RAW+: up to approx. 25 frames • When the sensitivity is set to ISO100 • The shooting speed slows down when the electronic shutter is used or a higher sensitivity is set.
Multi-exposure	Composite Mode: Additive, Average, Bright Number of Shots: 2 to 2000 times

Interval Shooting	<p>[Interval Shooting] Interval: 2 sec. to 24 hr., Standby Interval: minimum time or 1 sec. to 24 hr., Number of Shots: 2 to 2000 times, Start Interval: Now, Self-timer, Set Time</p> <p>[Interval Composite] Interval: 2 sec. to 24 hr., Standby Interval: minimum time or 1 sec. to 24 hr., Number of Shots: 2 to 2000 times, Start Interval: Now, Self-timer, Set Time, Composite Mode: Additive, Average, Bright, Save Process: On, Off</p> <p>[Interval Movie Record] Recorded Pixels: <b>[4K]</b>, <b>[FullHD]</b>, <b>[HD]</b>, Recording Format: Motion JPEG (AVI), Interval: 2 sec. to 24 hr., Standby Interval: minimum time or 1 sec. to 24 hr., Number of Shots: 8 to 2000 times (When <b>[4K]</b> is selected: 8 to 500 times), Start Interval: Now, Self-timer, Set Time</p> <p>[Star Stream] Recorded Pixels: <b>[4K]</b>, <b>[FullHD]</b>, <b>[HD]</b>, Recording Format: Motion JPEG (AVI), Standby Interval: minimum time or 1 sec. to 24 hr., Number of Shots: 8 to 2000 times (When <b>[4K]</b> is selected: 8 to 500 times), Start Interval: Now, Self-timer, Set Time, Fade-out: Off, Low, Medium, High</p>
-------------------	--

## Flash

Built-in Flash	<p>Built-in retractable P-TTL pop-up flash Guide number: approx. 6.0 (ISO100/m) Angle of view coverage: equivalent to 28mm lens in 35 mm format</p>
Flash Modes	<p>Auto Flash Discharge (Scene Analyze Auto), Auto Flash + Red-eye Reduction (Scene Analyze Auto), Flash On, Flash On + Red-eye Reduction, Slow-speed Sync, Slow-speed Sync + Red-eye Reduction, Trailing Curtain Sync, Manual Flash Discharge (FULL to 1/128 power), Wireless Flash Discharge (Controller Flash)</p>
Sync Speed	1/180 seconds
Flash Exposure Compensation	-2.0 to +1.0 EV
External Flash	<p>P-TTL, Leading Curtain Sync, Trailing Curtain Sync, Contrast Control Sync*, High-speed Sync, Wireless Sync * Available with two or more compatible external flash units</p>

## Capture Functions

Custom Image	Auto Select, Bright, Natural, Portrait, Landscape, Vibrant, Radiant, Muted, Flat, Bleach Bypass, Reversal Film, Monochrome, Cross Processing
Cross Processing	Random, Preset 1-3, Favorite 1-3
Digital Filter	Extract Color, Replace Color, Toy Camera, Retro, High Contrast, Shading, Invert Color, Unicorn Bold, Bold Monochrome
Clarity	-4.0 to +4.0
Skin Tone	Type1, Type2, Off
HDR Capture	Auto, Type1, Type2, Type3, Advanced HDR, Off Bracket Value: adjustable Auto Align (automatic composition correction function): available
Pixel Shift Resolution	On, Off Motion Correction: On, Off
Lens Correction	Distortion Correction, Peripheral Illumination Correction, Lateral Chromatic Aberration Adjustment, Diffraction Correction
D-Range Settings	Highlight Correction, Shadow Correction
Noise Reduction	Slow Shutter Speed NR, High-ISO NR
Horizon Correction	SR On: corrects up to 1.0 degree SR Off: corrects up to 1.5 degrees
Composition Adjustment	Adjustment range of $\pm 1$ mm up, down, left or right ( $\pm 0.5$ mm when rotated); rotating range of $\pm 1$ degree
Electronic Level	Displayed in viewfinder (horizontal direction only); displayed on monitor (horizontal direction and vertical direction)
Program Line	Auto, Standard, Hi-speed Priority, DOF Priority (Deep), DOF Priority (Shallow), MTF Priority

## Movie

Recording Format	MPEG-4 AVC/H.264 (MOV)
Recorded Pixels/Frame Rate	<b>[FullHD]</b> (1920×1080, 60i/50i/30p/25p/24p) <b>[HD]</b> (1280×720, 60p/50p)
Autofocusing System	<p>AF Method: Contrast detection AF AF Mode: Single AF (<b>AFS</b>), Continuous AF (<b>AFC</b>) * Continuous AF (<b>AFC</b>) is available only when a compatible lens is attached to the camera. AF Active Area: Multiple AF Points, Select, Spot Focus Peaking: Highlight Edge, Extract Edge, Off</p>









Sound	Built-in stereo microphone, external microphone (stereo recording compatible) Recording Sound Level: adjustable
Recording Time	Up to 4 GB or approx. 25 minutes; automatically stops recording if the internal temperature of the camera becomes high.
Custom Image	Auto Select, Bright, Natural, Portrait, Landscape, Vibrant, Radiant, Muted, Flat, Bleach Bypass, Reversal Film, Monochrome, Cross Processing
Cross Processing	Random, Preset 1-3, Favorite 1-3
Digital Filter	Extract Color, Replace Color, Toy Camera, Retro, High Contrast, Shading, Invert Color, Unicolor Bold, Bold Monochrome

### Playback Functions

Playback View	Single image, Multi-image display (6, 12, 20, 35, and 80 thumbnails), Image magnification (Up to 16×, Quick Zoom), Grid Display (4×4 Grid, Golden Section, Scale, Square 1, Square 2, Grid Color: Black, White), Rotated image display, Histogram Display (Y histogram, RGB histogram), Highlight Alert, Auto Image Rotation, Detailed Information Display, Copyright Information (Photographer, Copyright Holder), GPS information (Latitude, Longitude, Altitude, Coordinated Universal Time (UTC)), Direction, Folder Display, Calendar Filmstrip Display, Slideshow
Delete	Single image, all images, select & delete, folder, Instant Review image
Digital Filter	Base Parameter Adj, Extract Color, Replace Color, Toy Camera, Retro, High Contrast, Shading, Invert Color, Unicolor Bold, Bold Monochrome, Tone Expansion, Sketch, Water Color, Pastel, Posterization, Miniature, Soft, Starburst, Fish-eye, Slim, Monochrome

RAW Development	Development options: Select single image, Select multiple images, Select a folder Development parameters: White Balance, Custom Image, Sensitivity, Clarity, Skin Tone, Digital Filter, HDR Capture, Pixel Shift Resolution, Shadow Correction, High-ISO NR, Distortion Correction, Peripheral Illumination Correction, Lateral Chromatic Aberration Adjustment, Diffraction Correction, Color Fringe Correction, File Format (JPEG, TIFF), Aspect Ratio, JPEG Recorded Pixels, JPEG Quality, Color Space
Editing Features	Image Rotation, Color Moiré Correction, Resize, Cropping (aspect ratio can be changed and tilt correction is available), Movie Edit (dividing a movie file and deleting unwanted segments), Capturing a JPEG still picture from a movie, Save RAW Data

### Customization

USER Modes	Up to 5 settings can be saved.
Function Dial	C1, C2, C3 Assignable items: Sensitivity, EV Compensation, Bracket Value, Custom Image, AF Mode, AF Active Area, Focus Peaking, Program Line, Shutter Mode Selection, Recorded Pixels (Still picture:  ,  ,  ,  ), AA Filter Simulator, Grid Display, LCD Display Options, Image Magnification, Outdoor View Setting
Custom Functions	24 items
Mode Memory	18 items
Button Customization	 button: EV Compensation, Sensitivity, Preview, AE Lock, Change AF Area, One Push File Format, Electronic Level, Wi-Fi, Night Vision LCD Display, Operation Control Lock  /  button: EV Compensation, Sensitivity, Preview, AE Lock, Change AF Area, One Push File Format, Electronic Level, Operation Control Lock  /  button: Enable AF1, Enable AF2, Cancel AF, AE Lock E-dials (front/rear): customizable to each exposure mode
AF Customization	AF.S Setting: Focus-priority, Release-priority 1st Frame Action in AF.C: Auto, Focus-priority, Release-priority Action in AF.C Continuous: Auto, Focus-priority, FPS-priority Hold AF Status: Off, Low, Medium, High AF in Interval Shooting: Locks focus at 1st exposure, Adjusts focus for each shot

Enable/Disable Control	Type1: Disables exposure control operations in standby mode Type2: Disables the control functions of ▲▼◀▶, <b>OK</b> , and <b>MENU</b> in standby mode
Text Size	Standard, Large
World Time	World Time settings for 75 cities (28 time zones)
AF Fine Adjustment	±10 steps, uniform adjustment for all lenses or individual adjustment for each lens (up to 20 values can be saved)
Indicator Lamps	Self-timer: On, Off GPS LED Indicators: On, Off
Copyright Information	Names of "Photographer" and "Copyright Holder" are embedded to the image file. A revision history can be checked using the provided software.

### Power Supply

Battery Type	Rechargeable Lithium-ion Battery D-LI109
AC Adapter	AC Adapter Kit K-AC167 (optional)
Battery Life	Number of recordable images (with 50% flash usage): approx. 390 images (without flash usage): approx. 420 images Playback time: approx. 270 minutes • Tested in compliance with CIPA standard using a fully charged lithium-ion battery at a temperature of 23°C. Actual results may vary depending on the shooting conditions/circumstances.

### Interfaces

Connection Port	USB 2.0 (micro B), external power supply terminal, stereo microphone/cable release input terminal (ø3.5 mm connector)
USB Connection	MSC/PTP
Video Output	USB/Video output terminal • SlimPort®-to-HDMI® adapter required

### Wireless LAN

Standards	IEEE 802.11b/g/n (standard wireless LAN protocol)
Frequency (Center Frequency)	2412 to 2462 MHz (channels: Ch 1 to Ch 11)
Security	Authentication: WPA2 Encryption: AES

### Dimensions and Weight

Dimensions	Approx. 131.5 mm (W) × 101.0 mm (H) × 76.0 mm (D) (excluding protrusions)
Weight	Approx. 703 g (including dedicated battery and an SD Memory Card) Approx. 643 g (body only)

### Operating Environment

Temperature	-10 to 40°C (14 to 104°F)
Humidity	85% or less (no condensation)

### Included Accessories

Package Contents	Strap O-ST162, Rechargeable Lithium-ion Battery D-LI109, Battery Charger D-BC109, AC plug cord, Software (CD-ROM) S-SW167, Operating Manual <Mounted to the camera> Eyecup FR, Hot shoe cover Fκ, Body mount cap K II, Triangular ring and protective cover, Grip S O-GP167, Battery grip terminal cover
Software	Digital Camera Utility 5

### Optional Accessories

GPS Unit	O-GPS1: GPS information (Latitude, Longitude, Altitude, Coordinated Universal Time (UTC)), Direction, Electronic Compass, ASTROTRACER
Cable Release	Cable Switch CS-310
Battery Grip	D-BG7
Grip	Grip S: O-GP167 Grip M: O-GP1671 Grip L: O-GP1672

## Approximate Image Storage Capacity and Playback Time

(When using the fully charged battery)

Battery	Temperature	Normal Shooting	Flash Photography		Playback Time
			50% Use	100% Use	
D-LI109	23°C	420	390	360	270 minutes

- Tested in compliance with CIPA standard using a fully charged lithium-ion battery at a temperature of 23°C. Actual results may vary depending on the shooting conditions/circumstances.

## Approximate Image Storage Capacity by Size

(When using an 8 GB memory card)

Recorded Pixels	JPEG Quality			PEF
	★★★	★★	★	
<b>L</b> 24M	527	1192	2339	151
<b>M</b> 14M	889	1996	3837	–
<b>S</b> 6M	1964	4309	7923	–
<b>XS</b> 2M	4723	9824	16374	–

- The number of storable images may vary depending on the subject, shooting conditions, selected capture mode, and memory card, etc.

## List of World Time Cities

The following cities can be set as Hometown and Destination.

Region	City
<b>North America</b>	Honolulu, Anchorage, Vancouver, San Francisco, Los Angeles, Calgary, Denver, Chicago, Miami, Toronto, New York, Halifax
<b>Central and South America</b>	Mexico City, Lima, Santiago, Caracas, Buenos Aires, Sao Paulo, Rio de Janeiro
<b>Europe</b>	Lisbon, Madrid, London, Paris, Amsterdam, Milan, Rome, Copenhagen, Berlin, Prague, Stockholm, Budapest, Warsaw, Athens, Helsinki, Moscow
<b>Africa/ West Asia</b>	Dakar, Algiers, Johannesburg, Istanbul, Cairo, Jerusalem, Nairobi, Jeddah, Tehran, Dubai, Karachi, Kabul, Male, Delhi, Colombo, Kathmandu, Dacca
<b>East Asia</b>	Yangon, Bangkok, Kuala Lumpur, Vientiane, Singapore, Phnom Penh, Ho chi Minh, Jakarta, Hong Kong, Beijing, Shanghai, Manila, Taipei, Seoul, Tokyo, Guam
<b>Oceania</b>	Perth, Adelaide, Sydney, Noumea, Wellington, Auckland, Pago Pago

## Operating Environment for USB Connection and Provided Software

With the provided software “Digital Camera Utility 5”, you can develop RAW images, make color adjustments, or check shooting information on a computer. Install the software from the provided CD-ROM (S-SW167).

We recommend the following system requirements to connect the camera to a computer with a commercially available USB cable and to use the software.

### Windows®

<b>OS</b>	Windows® 10 (32-bit, 64-bit), Windows® 8.1 (32-bit, 64-bit), Windows® 8 (32-bit, 64-bit), or Windows® 7 (32-bit, 64-bit)
<b>CPU</b>	Intel® Core™ 2 Duo or higher
<b>RAM</b>	4 GB or more
<b>HDD</b>	For installing and starting up the program: Approx. 100 MB or more of available space For saving image files: Approx. 10 MB/file (JPEG), Approx. 30 MB/file (RAW)
<b>Monitor</b>	1280×1024 dots, 24-bit full color or higher

### Macintosh

<b>OS</b>	OS X 10.12, OS X 10.11, OS X 10.10, OS X 10.9, or OS X 10.8
<b>CPU</b>	Intel® Core™ 2 Duo or higher
<b>RAM</b>	4 GB or more
<b>HDD</b>	For installing and starting up the program: Approx. 100 MB or more of available space For saving image files: Approx. 10 MB/file (JPEG), Approx. 30 MB/file (RAW)
<b>Monitor</b>	1280×1024 dots, 24-bit full color or higher

### Memo

- Application software that supports both MOV (MPEG-4AVC/H.264) and AVI (Motion JPEG) formats is required to play back movie files transferred to a computer.

## Symbols

menus .....	24
menus .....	29
menu .....	31
menus .....	32
menus .....	34
mode .....	52
/LV/ switch .....	44, 46, 52

## Numerics

1st Frame Action in AF.C .....	59
4-way Controller Settings .....	61

## A

AA Filter Simulator .....	79
AC adapter .....	40
Action in AF.C Continuous .....	59
AdobeRGB .....	48
AE Lock .....	51
AE Metering .....	57
AE-L with AF Locked .....	34
AF Active Area .....	60, 62
AF Assist Light .....	10, 60
AF coupler .....	10
AF Fine Adjustment .....	63
AF frame .....	45, 46
AF in Interval Shooting .....	71
AF Mode .....	60, 62
AF point .....	60
AF with Live View .....	61
AF with Viewfinder .....	59
<b>AFA</b> .....	60
<b>AFC</b> .....	60

## AFS

AF.S Setting .....	59, 61
AF/AE-L Button .....	103
<b>AF/MF</b> switch .....	44, 59
Anti-aliasing filter .....	79
Aperture Priority Automatic Exposure .....	49
Aperture value .....	49
Aspect Ratio .....	86, 90
ASTROPHOTO .....	48
ASTROTRACER .....	121
Auto (AF Active Area) .....	60
Auto EV Compensation .....	34
Auto Flash + Red-eye .....	57
Auto Flash Discharge .....	57
Auto Image Rotation .....	84
<b>AUTO</b> mode .....	44
Auto Power Off .....	42
Auto Select (Custom Image) .....	74
Auto SR Off .....	64
Auto White Balance (White Balance) .....	72
Autofocus .....	59
<b>Av</b> bracketing .....	67
AV device .....	85
<b>Av</b> mode .....	49
AWB in Tungsten Light .....	72

## B

<b>B</b> mode .....	49
Base Parameter Adjustment (Digital Filter) .....	87
Battery .....	38
Battery grip .....	39
Battery grip terminal .....	10

Bleach Bypass (Custom Image) .....	74
Bold Monochrome (Digital Filter) .....	75, 87
Bracketing .....	66
Bracketing Order .....	66
Bright (Custom Image) .....	74
Brightness adjustment .....	76
Brightness histogram .....	18
Built-in flash .....	10, 57
Bulb (B) Mode Options .....	51
Bulb Exposure .....	49, 51
Button .....	11
Button Customization .....	102

## C

Cable release .....	53
Cable release terminal .....	53
Calendar Filmstrip Display .....	83
Calibration .....	121
Capture mode .....	48
Card .....	40
Card access lamp .....	10
Catch-in Focus .....	119
Center-weighted metering .....	57
Certification Marks .....	138
Changing the image size .....	86
Charging the battery .....	38
Charging time .....	38
City names .....	42, 131
Clarity .....	78
Cleaning .....	124
Cloudy (White Balance) .....	72
Color Fringe Correction .....	90

Color Moiré Correction .....	87
Color Space .....	48
Color Temperature (White Balance) .....	73
Color Temperature Steps .....	73
Communication device .....	94
Composition Info .....	94
Composition Adjustment .....	80
Computer .....	92
Continuous mode (AF Mode) .....	60
Continuous playback .....	84
Continuous Shooting .....	65
Contrast (Custom Image) .....	74
Contrast detection AF .....	59
Control panel .....	15, 21
Controller flash .....	120
Copyright Holder .....	113
Copyright Information .....	113
Correcting images .....	76
Create New Folder .....	111
Cropping .....	86
Cross Processing (Custom Image) .....	74
<b>CTE</b> (White Balance) .....	72
Custom Image .....	74
Custom Setting menus .....	34
Customization .....	22, 102

## D

Date Adjustment .....	43
Date Format .....	43
Daylight (White Balance) .....	72
DC input terminal .....	40

Delete .....	47	Error messages .....	125	Framerate .....	48	Initial settings .....	42
Deleting all images .....	31	EV Compensation .....	56	Function Dial .....	21, 105	Initializing a memory card .....	
Deleting selected images .....		EV Steps .....	50	Fx1/Fx2/Fx3 button .....	102	.....	44
.....	82	Exif data .....	113	<b>G</b>		Input Focal Length .....	119
Depth of field .....	51	Expanded Area AF (AF		GPS Time Sync .....	121	Instant Review .....	26, 45
Depth of Field Bracketing .....	67	Active Area) .....	60	GPS unit .....	121	Interval Composite .....	70
Destination .....	114	Exposure modes .....	49, 109	GPS/E-Compass .....	121	Interval Movie Record .....	70
Detailed Information Display .....	17	External flash .....	120	Grid Display .....	26, 47	Interval Shooting .....	70
Developing RAW images .....		Extract Color (Digital Filter)		Grip .....	36	Interval Shooting Options .....	
.....	90	.....	75, 87	Guide Display .....	45	Invert Color (Digital Filter)	
Dial .....	11	<b>F</b>		Guide number .....	58	.....	75, 87
Dial indicator .....	45	Face Detection (AF Active		<b>H</b>		ISO AUTO Setting .....	55
Diffraction Correction .....	77	Area) .....	62	HDMI® terminal .....	85	ISO sensitivity .....	54
Digital Camera Utility 5 .....		File Format .....	48	HDR Capture .....	77	<b>J</b>	
.....	91, 132	File Name .....	112	HDR LANDSCAPE .....	48	JPEG .....	48
Digital Filter .....	75, 87	File No. ....	113	High Contrast (Digital Filter)		JPEG Quality .....	48
Digital Preview .....	104	Filter .....	75, 87	.....	75, 87	JPEG Recorded Pixels .....	48
Diopter adjustment lever .....		Firmware Info/Options .....	33	High-ISO NR .....	55	<b>K</b>	
.....	19	Fish-eye (Digital Filter) .....	87	Highlight Alert .....	17, 26	Kelvin .....	73
Direct keys .....	20	Flash .....	57, 120	Highlight Correction .....	76	<b>L</b>	
Disabling dial and button		Flash compensation .....	58	High-speed Sync flash ..	120	Landscape (Custom Image)	
operations .....	51	Flash On .....	57	Histogram Display .....	18, 26	.....	74
Display Color .....	43	Flash On + Red-eye .....	57	Hold AF Status .....	59	Language/言語 .....	42
Distortion Correction .....	77	Flat (Custom Image) .....	74	Hometown .....	42, 114	Language setting .....	42
DNG .....	48	Flicker Reduction .....	26	Horizon Correction .....	26	Lateral Chromatic Aberration	
D-Range Settings .....	76	Fluorescent - Cool White		Hot shoe .....	10	Adjustment .....	77
Drive Mode .....	64	(White Balance) .....	72	<b>I</b>		LCD Display .....	31, 43
DST (daylight saving time)		Fluorescent - Daylight Color		Image Capture Settings ...	48	LCD Display Settings .....	107
.....	42, 114	(White Balance) .....	72	Image finishing tone .....	74	Lens .....	37, 116
Dust Removal .....	123	Fluorescent - Daylight White		Image plane indicator .....	10	Lens Correction .....	77
Dynamic range .....	76	(White Balance) .....	72	Image Rotation .....	84	Lens focal length .....	119
<b>E</b>		Fluorescent - Warm White		Image storage capacity .....	131	Lens information contacts	
E-dial .....	106	(White Balance) .....	72	.....		.....	10
Editing images .....	86	Focus indicator .....	45	Image Sync .....	94	Lens mount index .....	37
Electronic Compass .....		Focus Method .....	59	IMAGE Transmitter 2 .....	93	Lens unlock button .....	37
.....	16, 121	Focus Peaking .....	61	Image View (Image Sync)		Lens with aperture ring ..	118
Electronic Level .....	16, 20	Folder display .....	83	.....	94	Link AE and AF Point .....	57
Electronic Shutter .....	52	Folder Name .....	111	Indicator Lamps .....	108		
Enable/Disable Control .....	51	Format .....	44				
		Four-way controller .....	12, 20				



Live View .....	14	Multi-exposure .....	69	Power .....	42	<b>S</b>	
<b>M</b>		Multi-image display.....	82	Precise Calibration .....	121	Save as Manual WB .....	73
<b>M</b> mode .....	49	Multiple AF Points (AF Active Area).....	86	Preview.....	51, 104	Save Cross Processing... 75	
Macintosh.....	132	Multi-segment metering... 57		Processing images .....	86	Save Menu Location.....	23
MACRO .....	48	Muted (Custom Image).... 74		Program Automatic Exposure .....	49	Save RAW Data .....	45, 47
Magnifying images ... 46, 47		<b>N</b>		Program Line .....	50	Save Rotation Info .....	84
Manual Exposure .....	49	Natural (Custom Image) .. 74		Protect .....	110	Save USER Mode .....	108
Manual Flash Discharge.. 57		Night Vision LCD Display .....	122	Protect All Images .....	110	Scene Analyze Auto mode .....	44
MANUAL LENS .....	48	Noise Reduction .....	50, 55	Provided software.....	132	SD Memory Card.....	40
Manual White Balance ... 73		<b>O</b>		PTP .....	92	Select (AF Active Area) .....	60, 62
Mechanical Shutter.....	52	One Push File Format ... 103		<b>Q</b>		Select Battery .....	39
Memory .....	110	One-Push Bracketing .....	66	Quality .....	48	Self-timer .....	65
Memory card .....	40	Operating environment.. 132		Quality level adjustment .. 78		Self-timer lamp .....	10
Menu .....	23	Optical Preview .....	104	Quick Zoom .....	47	Sensitivity .....	54
Meter Operating Time .... 19		Other Display Settings..... 27		<b>R</b>		Sensitivity Priority Automatic Exposure .....	49
Microphone.....	10, 53	Outdoor View Setting .... 108		Radiant (Custom Image) .....	74	Sensitivity Steps .....	54
Microphone terminal..... 53		<b>P</b>		RAW .....	48	Sensor Cleaning.....	124
Microphone/cable release terminal.....	10	<b>P</b> mode .....	49	RAW Development.....	90	Sequential Numbering... 113	
Miniature (Digital Filter) ... 87		Pastel (Digital Filter) .....	87	RAW File Format.....	48	Setting dial.....	21
Mired .....	73	PEF .....	48	Rec. Mode menus .....	24	Set-up menus .....	32
Mirror .....	10	Peripheral Illumination Correction.....	77	Recordable time .....	52	Shade (White Balance).... 72	
Mirror Lock-up Shooting .. 69		Phase-matching AF .....	59	Recorded Pixels .....	48	Shading (Digital Filter) .....	75, 87
Mode dial .....	45	Photographer.....	113	Recording Sound Level ... 53		Shadow Correction.....	76
Mode dial lock button .....	45	Pixel Mapping .....	123	Release While Charging.. 58		Shake Reduction .....	26
Moiré reduction.....	79	Pixel Shift Resolution .....	78	Remote Capture (Image Sync).....	94	Sharpness (Custom Image) .....	74
Monitor .....	13, 41	Playback Info Display selection screen .....	17	Replace Color (Digital Filter) .....	75, 87	Shooting .....	44
Monochrome (Custom Image).....	74	Playback menu .....	31	Reset .....	33, 35	Shooting celestial bodies .....	121
Monochrome (Digital Filter) .....	87	Playback mode.....	47	Resize .....	86	Shooting Info Display.....	16
Motion Bracketing.....	68	Playback mode palette .... 81		Retractable lens .....	46	Shooting with Live View... 46	
Mount type .....	116	Playback Sound Volume .....	54	Retro (Digital Filter) ... 75, 87		Shooting with viewfinder.. 44	
Movie Edit.....	89	Portrait (Custom Image) .. 74		Reversal Film (Custom Image) .....	74	Shutter & Aperture Priority Automatic Exposure .....	49
Movie menus .....	29	Posterization (Digital Filter) .....	87	RGB histogram .....	18	Shutter Mode Selection ... 52	
Movie mode.....	52			Rotating images .....	84	Shutter Priority Automatic Exposure .....	49
Movie SR.....	29			Rotation Direction.....	107		
MSC .....	92						
Multi Auto White Balance (White Balance).....	72						

Shutter speed .....	49	TIFF .....	90	White Balance .....	72
Single Frame Shooting ....	64	Time Setting .....	114	Wi-Fi™ .....	93
Single image display .....	17, 47	Timed exposure .....	51	Windows® .....	132
Single mode (AF Mode) ..	60	Tone Expansion (Digital Filter) .....	87	Wireless flash discharge .....	57
Sketch (Digital Filter) .....	87	Toy Camera (Digital Filter) .....	75, 87	Wireless LAN .....	93
Skin Tone .....	78	Tracking (AF Active Area) .....	62	World Time .....	114
Slideshow .....	84	Trailing Curtain Sync .....	57		
Slim (Digital Filter) .....	87	TTL phase-matching AF .....	59	<b>Z</b>	
SlimPort® .....	85	Tungsten (White Balance) .....	72	Zone Select (AF Active Area) .....	60
Slow Shutter Speed NR ..	50	<b>Tv</b> bracketing .....	68		
Slow Sync + Red-eye .....	57	<b>Tv</b> mode .....	49		
Slow-speed Sync .....	57				
Smart Function .....	21, 105	<b>U</b>			
Smartphone .....	93	Unicolor Bold (Digital Filter) .....	75, 87		
Soft (Digital Filter) .....	87	USB Connection .....	92, 132		
Sound .....	52	USB terminal .....	92		
Sound Effects .....	32	USB/video output terminal .....	10		
Speaker .....	10	User registration .....	9		
Specifications .....	126	Using Aperture Ring .....	118		
Spot (AF Active Area) .....	60, 62	<b>V</b>			
Spot metering .....	57	Vibrant (Custom Image) ..	74		
sRGB .....	48	Video Out Resolution .....	85		
Standby mode .....	13	Viewfinder .....	19		
Star Stream .....	70	Viewfinder Overlay .....	26		
Starburst (Digital Filter) ...	87	Volume .....	32		
Status Screen .....	14	Volume label .....	44		
Strap .....	36				
Strap lug .....	36	<b>W</b>			
Superimpose AF Area .....	19	WARRANTY POLICY .....	141		
<b>Sv</b> mode .....	49	Water Color (Digital Filter) .....	87		
Switch .....	11	WB Adjustable Range .....	72		
		WB When Using Flash .....	72		
<b>T</b>					
<b>TAv</b> mode .....	49				
Tethered shooting .....	93				
Text input .....	109, 111				
Text Size .....	42				
Texture adjustment .....	78				
Thumbnail display .....	47, 82				

## Care to be Taken During Handling

### Before Using Your Camera

- When the camera has not been used for a long time, confirm that it is still working properly, particularly prior to taking important pictures (such as at a wedding or when traveling). Contents of the recording cannot be guaranteed if recording, playback or transferring your data to a computer, etc. is not possible due to a malfunction of your camera or recording media (memory cards), etc.

### About the Battery and Charger

- To keep the battery in optimum condition, avoid storing it in a fully charged state or in high temperatures.
- If the battery is left inserted and the camera is not used for a long time, the battery will over-discharge and shorten the battery's life.
- Charging the battery a day before use or on the day of use is recommended.
- The AC plug cord provided with this camera is developed exclusively for the battery charger D-BC109. Do not use it with other devices.
- Class II equipment: The provided battery charger is a Class II (double-insulated) product.

### Precautions on Carrying and Using Your Camera

- Do not subject the camera to high temperatures or high humidity. Do not leave the camera in a vehicle, as the temperature can get very high.
- Do not subject the camera to strong vibrations, shocks, or pressure. Use a cushion to protect the camera from vibrations of motorcycles, automobiles, or ships.
- The temperature range for camera use is -10°C to 40°C (14°F to 104°F). The monitor may appear black at high temperatures, but will return to normal at normal temperatures.
- The monitor may respond more slowly at low temperatures. This is due to liquid crystal properties, and is not a malfunction.
- Sudden temperature changes will cause condensation on the inside and outside of the camera. Place the camera in your bag or a plastic bag, and remove it after temperatures of the camera and surroundings are equalized.
- Avoid contact with garbage, mud, sand, dust, water, toxic gases, or salt. These could cause the camera to breakdown. Wipe the camera to dry off any rain or water drops immediately.
- Do not attach or remove a lens when there are any rain or water drops on the camera. If water enters the camera or the lens, a malfunction may occur.

- Do not press on the monitor with excessive force. This could cause it to break or malfunction.
- Be careful not to overtighten the screw in the tripod socket when using a tripod.

### Cleaning Your Camera

- Do not clean the camera with organic solvents such as thinner, alcohol, and benzene.
- Use a lens brush to remove dust accumulated on a lens. Never use a spray blower for cleaning as it may damage the lens.
- Please contact your nearest service center for professional cleaning of the CMOS sensor. (This will involve a fee.)
- Periodic inspections are recommended every one to two years to maintain high performance.

### Storing Your Camera

- Do not store the camera with preservatives or chemicals. Storage in high temperatures and high humidity can cause mold to grow on the camera. Remove the camera from its case and store it in a dry and well-ventilated place.
- Avoid using or storing the camera where it may be exposed to static electricity or electrical interference.
- Avoid using or storing the camera in direct sunlight or in locations where it may be exposed to rapid changes in temperature or to condensation.

### About SD Memory Cards

- The SD Memory Card is equipped with a write-protect switch. Setting the switch to LOCK prevents new data from being recorded on the card, the stored data from being deleted, and the card from being formatted by the camera or a computer.
- The SD Memory Card may be hot when removing the card immediately after using the camera.
- Do not remove the SD Memory Card or turn off the power while the card is being accessed. This may cause the data to be lost or the card to be damaged.
- Do not bend the SD Memory Card or subject it to violent impact. Keep it away from water and store away from high temperatures.
- Do not remove the SD Memory Card while formatting. The card may be damaged and become unusable.

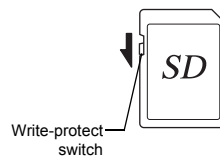

- Data on the SD Memory Card may be deleted in the following circumstances. We do not accept any liability for data that is deleted if
  1. the SD Memory Card is mishandled by the user.
  2. the SD Memory Card is exposed to static electricity or electrical interference.
  3. the SD Memory Card has not been used for a long time.
  4. the SD Memory Card or the battery is removed while the card is being accessed.
- If the SD Memory Card is not used for a long time, the data on the card may become unreadable. Be sure to regularly make a backup of important data on a computer.
- Format new SD Memory Cards. Also format SD Memory Cards previously used with other cameras.
- Please note that deleting data stored on an SD Memory Card, or formatting an SD Memory Card does not completely erase the original data. Deleted data can sometimes be recovered using commercially available software. If you are going to discard, give away or sell your SD Memory Card, you should ensure that the data on the card is completely deleted or the card itself is destroyed if it contains any personal or sensitive information.
- The data on your SD Memory Card should be managed at your own risk.

## About the Wireless LAN Function

- Do not use the camera in a place where electrical products, AV/OA devices, and so on generate magnetic fields and electromagnetic waves.
- If the camera is affected by magnetic fields and electromagnetic waves, it may not be able to communicate.
- If the camera is used near a TV or a radio, poor reception or TV screen glitch may occur.
- If there are multiple wireless LAN access points near the camera and the same channel is used, search operation may not be executed correctly.
- The security of your data stored, sent or received is your own responsibility.

In the frequency band used by the camera, along with industrial, scientific, and medical devices such as microwave ovens, premises radio stations (wireless stations requiring license) and specified low power radio stations (wireless stations not requiring license) for mobile object identification used in factory production lines, etc., and amateur radio stations (wireless stations requiring license) are operated.

1. Before using the camera, confirm that premises radio stations and specified low power radio stations for mobile object identification and amateur radio stations are not operated in the vicinity.
2. In the event that the camera causes harmful radio wave interference to premises radio stations for mobile object identification, immediately change the frequency being used to avoid interference.
3. If you have other troubles such that the camera causes harmful radio wave interference to specified low power radio stations for mobile object identification or to amateur radio stations, contact your nearest service center.

This camera conforms to the technical standards under the Radio Law and Telecommunications Business Law and the certification of conformance to technical standards can be displayed on the monitor.

The certification marks of conformance to wireless technical standards under the Radio Law and Telecommunications Business Law can be displayed from [Certification Marks] of the 5 menu. Refer to "Using the Menu" (p.23) for how to use the menu.

## Trademarks

- Microsoft and Windows are registered trademarks of Microsoft Corporation in the United States of America and other countries.
- Macintosh, macOS, OS X, and App Store are trademarks of Apple Inc., registered in the U.S. and other countries.
- Intel and Intel Core are trademarks of Intel Corporation in the U.S. and/or other countries.
- SDXC Logo is a trademark of SD-3C, LLC.
- Google, Google Play, and Android are trademarks or registered trademarks of Google Inc.
- Wi-Fi is a registered trademark of Wi-Fi Alliance.
- IOS is a trademark or registered trademark of Cisco in the U.S. and other countries and is used under license.
- This product includes DNG technology under license by Adobe Systems Incorporated.
- The DNG logo is either a registered trademark or trademark of Adobe Systems Incorporated in the United States and/or other countries.
- HDMI, the HDMI logo and High-Definition Multimedia Interface are trademarks or registered trademarks of HDMI Licensing, LLC in the United States and/or other countries.
- Analogix and SlimPort are trademarks or registered trademarks of Analogix Semiconductor, Inc.
- MHL, the MHL Logo, and Mobile High-Definition Link are trademarks or registered trademarks of MHL, LLC in the United States and other countries.

All other trademarks are the property of their respective owners.

- This product uses the RICOH RT font designed by Ricoh Company Ltd.
  - This product supports PRINT Image Matching III. PRINT Image Matching enabled digital still cameras, printers and software help photographers to produce images more faithful to their intentions. Some functions are not available on printers that are not PRINT Image Matching III compliant.
- Copyright 2001 Seiko Epson Corporation. All Rights Reserved. PRINT Image Matching is a trademark of Seiko Epson Corporation. The PRINT Image Matching logo is a trademark of Seiko Epson Corporation.



## AVC Patent Portfolio License

This product is licensed under the AVC Patent Portfolio License for the personal use of a consumer or other uses in which it does not receive remuneration to (i) encode video in compliance with the AVC standard ("AVC video") and/or (ii) decode AVC video that was encoded by a consumer engaged in a personal activity and/or was obtained from a video provider licensed to provide AVC video. No license is granted or shall be implied for any other use.

Additional information may be obtained from MPEG LA, L.L.C.  
See <http://www.mpegla.com>.

## Announcement on the Use of BSD-Licensed Software

This product includes software licensed under the BSD License. BSD license is a form of license which permits the redistribution of the software provided that it is clearly stated that use is unwarranted, and a copyright notice and a list of licensing conditions are provided. The following contents are displayed based on the abovementioned licensing conditions and are not for the purpose of restricting your use of the product, etc.

Tera Term  
Copyright (C) 1994-1998 T. Teranishi  
(C) 2004-2016 TeraTerm Project  
All rights reserved.

Redistribution and use in source and binary forms, with or without modification, are permitted provided that the following conditions are met:

1. Redistributions of source code must retain the above copyright notice, this list of conditions and the following disclaimer.
2. Redistributions in binary form must reproduce the above copyright notice, this list of conditions and the following disclaimer in the documentation and/or other materials provided with the distribution.
3. The name of the author may not be used to endorse or promote products derived from this software without specific prior written permission.

THIS SOFTWARE IS PROVIDED BY THE AUTHOR "AS IS" AND ANY EXPRESS OR IMPLIED WARRANTIES, INCLUDING, BUT NOT LIMITED TO, THE IMPLIED WARRANTIES OF MERCHANTABILITY AND FITNESS FOR A PARTICULAR PURPOSE ARE DISCLAIMED. IN NO EVENT SHALL THE AUTHOR BE LIABLE FOR ANY DIRECT, INDIRECT, INCIDENTAL, SPECIAL, EXEMPLARY, OR CONSEQUENTIAL DAMAGES (INCLUDING, BUT NOT LIMITED TO, PROCUREMENT OF SUBSTITUTE GOODS OR SERVICES; LOSS OF USE, DATA, OR PROFITS; OR BUSINESS INTERRUPTION) HOWEVER CAUSED AND ON ANY THEORY OF LIABILITY, WHETHER IN CONTRACT, STRICT LIABILITY, OR TORT (INCLUDING NEGLIGENCE OR OTHERWISE) ARISING IN ANY WAY OUT OF THE USE OF THIS SOFTWARE, EVEN IF ADVISED OF THE POSSIBILITY OF SUCH DAMAGE.

## WARRANTY POLICY

All our cameras purchased through authorized bona fide photographic distribution channels are guaranteed against defects of material or workmanship for a period of twelve months from the date of your purchase. Service will be rendered, and defective parts will be replaced without cost to you within that period, provided the camera does not show evidence of impact, sand or liquid damage, mishandling, tampering, battery or chemical corrosion, operation contrary to operating instructions, or modification by an unauthorized repair shop. The manufacturer or its authorized representatives shall not be liable for any repair or alterations except those made with its written consent and shall not be liable for damages from delay or loss of use or from other indirect or consequential damages of any kind, whether caused by defective material or workmanship or otherwise; and it is expressly agreed that the liability of the manufacturer or its representatives under all guarantees or warranties, whether expressed or implied, is strictly limited to the replacement of parts as hereinbefore provided. No refunds will be made on repairs by non-authorized service facilities.

### Procedure During 12-month Warranty Period

Any camera which proves defective during the 12-month warranty period should be returned to the dealer from whom you purchased the camera or to the manufacturer. If there are no representatives of the manufacturer in your country, send the camera to the manufacturer, with postage prepaid. In this case, it will take a considerable length of time before the camera can be returned to you owing to the complicated customs procedures required. If the camera is covered by warranty, repairs will be made and parts replaced free of charge, and the camera will be returned to you upon completion of servicing. If the camera is not covered by warranty, regular charges of the manufacturer or of its representatives will apply. Shipping charges are to be borne by the owner. If your camera was purchased outside of the country where you wish to have it serviced during the warranty period, regular handling and

servicing fees may be charged by the manufacturer's representatives in that country. Notwithstanding this, your camera returned to the manufacturer will be serviced free of charge according to this procedure and warranty policy. In any case, however, shipping charges and customs clearance fees to be borne by the sender. To prove the date of your purchase when required, please keep the receipt or bills covering the purchase of your camera for at least a year. Before sending your camera for servicing, please make sure that you are sending it to the manufacturer's authorized representatives or their approved repair shops, unless you are sending it directly to the manufacturer. Always obtain a quotation for the service charge, and only after you accept the quoted service charge, instruct the service station to proceed with the servicing.

- **This warranty policy does not affect the customer's statutory rights.**
- **The local warranty policies available from our distributors in some countries can supersede this warranty policy. Therefore, we recommend that you review the warranty card supplied with your product at the time of purchase, or contact our distributor in your country for more information and to receive a copy of the warranty policy.**

**For customers in USA**  
**STATEMENT OF FCC COMPLIANCE**

This device complies with Part 15 of the FCC Rules. Operation is subject to the following two conditions: (1) This device may not cause harmful interference, and (2) this device must accept any interference received, including interference that may cause undesired operation. Changes or modifications not approved by the party responsible for compliance could void the user's authority to operate the equipment.

This equipment has been tested and found to comply with the limits for a Class B digital device, pursuant to part 15 of the FCC Rules.

These limits are designed to provide reasonable protection against harmful interference in a residential installation. This equipment generates, uses and can radiate radio frequency energy and, if not installed and used in accordance with the instructions, may cause harmful interference to radio communications. However, there is no guarantee that interference will not occur in a particular installation. If this equipment does cause harmful interference to radio or television reception, which can be determined by turning the equipment off and on, the user is encouraged to try to correct the interference by one or more of the following measures:

- Reorient or relocate the receiving antenna.
  - Increase the separation between the equipment and receiver.
  - Connect the equipment into an outlet on a circuit different from that to which the receiver is connected.
- \* Consult the dealer or an experienced radio/TV technician for help.

**FOR CALIFORNIA, U.S.A. ONLY**

Perchlorate Material-special handling may apply.  
The lithium battery used in this camera contains perchlorate material, which may require special handling.  
See [www.dtsc.ca.gov/hazardouswaste/perchlorate](http://www.dtsc.ca.gov/hazardouswaste/perchlorate)

**Declaration of Conformity**  
According to 47CFR, Parts 2 and 15 for  
**Class B Personal Computers and Peripherals**

We: RICOH IMAGING AMERICAS CORPORATION

Located at: 5 Dedrick Place, West Caldwell, New Jersey 07006, U.S.A.  
Phone: 800-877-0155  
FAX: 973-882-2008

Declare under sole responsibility that the product identified herein complies with 47CFR Parts 2 and 15 of the FCC rules as a Class B digital device. Each product marketed is identical to the representative unit tested and found to be compliant with the standards. Records maintained continue to reflect the equipment being produced can be expected to be within the variation accepted, due to quantity production and testing on the statistical basis as required by 47CFR §2.909. Operation is subject to the following two conditions: (1) This device may not cause harmful interference, and (2) This device must accept any interference received, including interference that may cause undesired operation. The above named party is responsible for ensuring that the equipment complies with the standards of 47CFR §15.101 to §15.109.

Product Name: SLR Digital Camera

Model Number: PENTAX KP

Contact person: Customer Service Manager

Date and Place: January, 2017 Colorado



## For customers in Canada Industry Canada (IC) Compliance Notice

This Class B digital apparatus complies with Canadian ICES-003 (B).

This device complies with Industry Canada licence-exempt RSS standard(s). Operation is subject to the following two conditions: (1) this device may not cause interference, and (2) this device must accept any interference, including interference that may cause undesired operation of the device.

The available scientific evidence does not show that any health problems are associated with using low power wireless devices. There is no proof, however, that these low power wireless devices are absolutely safe. Low power wireless devices emit low levels of radio frequency energy (RF) in the microwave range while being used. Whereas high levels of RF can produce health effects (by heating tissue), exposure of low-level RF that does not produce heating effects causes no known adverse health effects. Many studies of low-level RF exposures have not found any biological effects. Some studies have suggested that some biological effects might occur, but such findings have not been confirmed by additional research. The KP has been tested and found to comply with IC radiation exposure limits set forth for an uncontrolled environment and meets RSS-102 of the IC radio frequency (RF) Exposure rules.

## Pour les utilisateurs au Canada Industrie Canada (IC) Avis de Conformité

Cet appareil numérique de la classe B est conforme à la norme NMB-003 (B) du Canada.

Le présent appareil est conforme aux CNR d'Industrie Canada applicables aux appareils radio exempts de licence. L'exploitation est autorisée aux deux conditions suivantes : (1) l'appareil ne doit pas produire de brouillage, et (2) l'utilisateur de l'appareil doit accepter tout brouillage radioélectrique subi, même si le brouillage est susceptible d'en compromettre le fonctionnement.

Les connaissances scientifiques dont nous disposons n'ont mis en évidence aucun problème de santé associé à l'usage des appareils sans fil à faible puissance. Nous ne sommes cependant pas en mesure de prouver que ces appareils sans fil à faible puissance sont entièrement sans danger. Les appareils sans fil à faible puissance émettent une énergie fréquence radioélectrique (RF) très faible dans le spectre des micro-ondes lorsqu'ils sont utilisés. Alors qu'une dose élevée de RF peut avoir des effets sur la santé (en chauffant les tissus), l'exposition à de faibles RF qui ne produisent pas de chaleur n'a pas de mauvais effets connus sur la santé. De nombreuses études ont été menées sur les expositions aux RF faibles et n'ont découvert aucun effet biologique. Certaines études ont suggéré qu'il pouvait y avoir certains effets biologiques, mais ces résultats n'ont pas été confirmés par des recherches supplémentaires. Le KP a été testé et jugé conforme aux limites d'exposition aux rayonnements IC énoncées pour un environnement non contrôlé et respecte les règles d'exposition aux fréquences radioélectriques (RF) CNR-102 de l'IC.

## For Customers in Europe

### Information for Users on Collection and Disposal of Old Equipment and Used Batteries



#### 1. In the European Union

These symbols on the products, packaging and/or accompanying documents mean that used electrical and electronic equipment and batteries should not be mixed with general household waste.

Used electrical/electronic equipment and batteries must be treated separately and in accordance with legislation that requires proper treatment, recovery and recycling of these products.



By disposing of these products correctly you will help ensure that the waste undergoes the necessary treatment, recovery and recycling and thus prevent potential negative effects on the environment and human health which could otherwise arise due to inappropriate waste handling.

If a chemical symbol is added beneath the symbol shown above, in accordance with the Battery Directive, this indicates that a heavy metal (Hg = Mercury, Cd = Cadmium, Pb = Lead) is present in the battery at a concentration above an applicable threshold specified in the Battery Directive.

For more information about collection and recycling of used products, please contact your local authorities, your waste disposal service or the point of sale where you purchased the products.

#### 2. In other countries outside the EU

These symbols are only valid in the European Union. If you wish to discard used products, please contact your local authorities or dealer and ask for the correct method of disposal.

For Switzerland: Used electrical/electronic equipment can be returned free of charge to the dealer, even when you don't purchase a new product. Further collection facilities are listed on the home page of [www.swico.ch](http://www.swico.ch) or [www.sens.ch](http://www.sens.ch).

### Notice to Users in EEA Countries

This product complies with the essential requirements and provisions of RE Directive 2014/53/EU. The CE Declaration of Conformity is available by accessing the URL:

[http://www.ricoh-imaging.co.jp/english/support/declaration\\_of\\_conformity.html](http://www.ricoh-imaging.co.jp/english/support/declaration_of_conformity.html)  
and selecting the product applicable.

Operating frequency band: 2400 MHz - 2483.5 MHz  
Maximum radio-frequency power: 8.16 dBm EIRP

European importer: RICOH IMAGING EUROPE S.A.S.  
Parc Tertiaire SILIC 7-9, avenue Robert Schuman - B.P. 70102,  
94513 Rungis Cedex, FRANCE

Manufacturer: RICOH IMAGING COMPANY, LTD.  
1-3-6, Nakamagome, Ohta-ku, Tokyo 143-8555, JAPAN



The CE Mark is a Directive conformity mark of the European Union.

**Memo**

**RICOH IMAGING COMPANY, LTD.**

1-3-6, Nakamagome, Ohta-ku, Tokyo 143-8555, JAPAN  
(<http://www.ricoh-imaging.co.jp>)

**RICOH IMAGING EUROPE  
S.A.S.**

Parc Tertiaire SILIC 7-9, avenue Robert Schuman - B.P. 70102,  
94513 Rungis Cedex, FRANCE  
(<http://www.ricoh-imaging.eu>)

**RICOH IMAGING AMERICAS  
CORPORATION**

5 Dedrick Place, West Caldwell, New Jersey 07006, U.S.A.  
(<http://www.us.ricoh-imaging.com>)

**RICOH IMAGING CANADA  
INC.**

5520 Explorer Drive Suite 300, Mississauga, Ontario, L4W 5L1, CANADA  
(<http://www.ricoh-imaging.ca>)

**RICOH IMAGING CHINA CO.,  
LTD.**

23D, Jun Yao International Plaza, 789 Zhaojabang Road, Xu Hui District,  
Shanghai, 200032, CHINA  
(<http://www.ricoh-imaging.com.cn>)

**<http://www.ricoh-imaging.co.jp/english>**

This contact information may change without notice.  
Please check the latest information on our websites.

- Specifications and external dimensions are subject to change without notice.