

RICOH
imagine. change.

PENTAX K-1



A full-frame SLR from the PENTAX K series

What's the best camera for a photographer?

Throughout more than 50 years as a leading SLR camera manufacturer, PENTAX has always thought very seriously about this question, and developed the original technologies to provide good answers. It's a history of never-ending innovation and evolution.

Based on its experiences and expertise accumulated over these years, PENTAX now has the final answer: a new 35mm full-frame digital SLR camera named PENTAX K-1. Proudly carrying the number "1" in its name, the K-1 reigns as the flagship of the acclaimed PENTAX K series.

While inheriting PENTAX's traditional compact, durable body design, the K-1 adds essential values to the 35mm full-frame format, including state-of-the-art high-resolution technologies drawn from PENTAX's development of medium-format models, an array of exclusive shooting features, and remarkable environmental adaptability in the field.

True to its number-1 naming, the PENTAX K-1 signifies the arrival of a new era in 35mm full-frame digital SLR cameras.

PENTAX
K-1





HD PENTAX-D FA 24-70mmF2.8ED SDM WR



Aperture : F8.0 ; Shutter speed : 1/125 sec. ; Exposure compensation : -0.7EV ; Sensitivity : ISO 200 ; White balance : Color temperature assigned ; Custom image : Landscape

35mm full-frame CMOS image sensor **NEW**

Exceptional imaging power assured by a large-format sensor

The K-1 incorporates a high-performance 35mm full-frame CMOS image sensor, one that assures the highest image quality to be found in the K-mount SLR series. Thanks to its large imaging area and wide pixel pitch, this high-pixel sensor delivers lively, true-to-life images with rich gradation and minimal noise. Its shallow depth of field allows you to control the sense of depth and bokeh (defocused) effect at will.

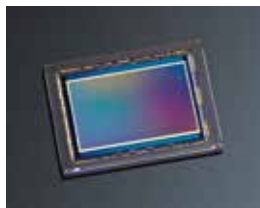

PRIME IV **NEW**

A new imaging engine optimized for a 35mm full-frame image circle

The K-1 features a newly designed PRIME IV imaging engine. Compared with the previous PRIME III version, it is fine-tuned to process higher-resolution images, while boosting the operating frequency by nearly 50 percent. Its noise-processing algorithm has also been upgraded to capture beautiful, fine-gradation images at higher sensitivities. A combination of an advanced scene analysis system and new image-processing functions helps improve the accuracy and reliability of image reproduction.



PRIME IV
PENTAX Real Image Engine IV

Approximately 36.4 effective megapixels

Exceptional resolving power supported by a high-resolution, AA-filter-free design

Thanks to its approximately 36.4 effective megapixels, the K-1 delivers breathtaking, true-to-life images — the kind that will seize the viewer's imagination. Its exceptional resolving power captures each leaf of a distant tree or every drop of a spray in the finest detail. Since it provides image data large enough to produce a brilliant A2-size print (at 300dpi), the photographer is assured of great flexibility in image composition, either by cropping the image during shooting, or trimming the captured image during processing. By processing large volumes of data with its 14-bit image-processing system, the K-1 delivers beautiful, rich-gradation images.

AA-filter-free design, to optimize resolving power

An optical AA (anti-aliasing) filter will affect the camera's image resolving power, even though it will help reduce moiré and false color. The K-1 incorporates an AA-filter-free design to optimize the image resolving power of its high-pixel image sensor.

ISO 204800 **NEW**

A combination of super-high sensitivity and exceptional image resolution

By taking full advantage of the image sensor excelled in noise-resistance performance and the PRIME IV imaging engine, the K-1 provides a top sensitivity of ISO 204800 (at standard output sensitivity). This not only delivers high-resolution images free of tone jumps and graininess at high-sensitivity settings, but also improves image quality in the low-sensitivity range. Since the K-1 allows you to raise the sensitivity level to capture images equal in image quality to those taken at lower sensitivities, it expands the boundaries of photographic expression.



ISO102400

36.4 effective megapixels and ISO 204800

The K-1 assures the highest level of resolving power and sensitivity



Pixel Shift Resolution System

Reproduction of true-to-life, super-high-resolution images beyond actual pixels

Reinforced with the SR (Shake Reduction) mechanism, the K-1's Pixel Shift Resolution System* captures four images of the same scene by shifting the image sensor by a single pixel for each image, then synthesizes them into a single, super-high-resolution composite image. Compared to the conventional Bayer system, this innovative system obtains all RGB color data in each pixel to deliver beautiful images with far more truthful colors and much finer details, without any hint of false color. This system also reduces high-sensitivity noise to a minimum. The difference in image quality is evident at a glance, even without magnifying the captured image on a computer screen or producing a large-size print. Images captured by the Pixel Shift Resolution System can be saved as RAW-format files. You can develop these files within the camera body while adjusting various parameters or turning the Pixel Shift Resolution effect on and off to create a new image.



Pixel Shift Resolution : OFF



Pixel Shift Resolution : ON

* When using this system, the user is advised to stabilize the camera firmly on a tripod during shooting by setting the drive mode to self-timer or remote control, or using the mirror lock-up function. * When the subject is on the move or camera shake occurs, the desired effect may not be obtained.

Motion Correction function **NEW**

When shooting an image with the Pixel Shift Resolution System, the K-1 provides a new Motion Correction function. When this function is activated, the camera automatically detects the amount of subject motion during continuous shooting and minimizes negative effects during the synthesizing process.*

* The movement may not be sufficiently corrected when the subject is moving in certain directions and/or patterns. This function does not guarantee that the movement will be properly corrected for all subjects.

Check the video on Pixel Shift Resolution System



Conceptual illustrations of Pixel Shift Resolution System

1st image

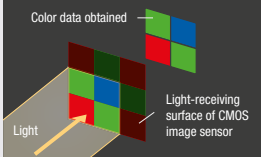

2nd image

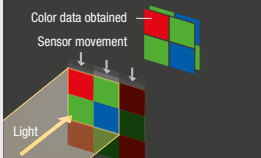

3rd image

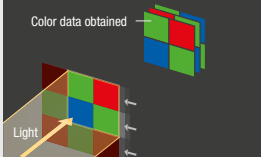

4th image

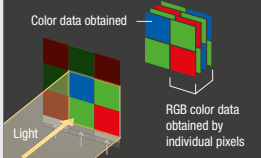

AA filter simulator

State-of-the-art mechanism to optically minimize moiré and false color

By using the camera's SR mechanism to apply microscopic vibrations to the image sensor, the PENTAX-original AA (anti-aliasing) filter simulator* effectively minimizes moiré and false color along the image's edges, which are common problems when shooting subjects with minute patterns. The K-1 allows you to faithfully reproduce your creative intention on a captured image, either by simulating the AA-filter effect for well-balanced images or by opting for the AA-filter-free mode for greater resolving power.

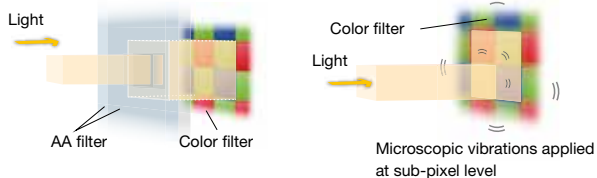

* This function works most effectively with a shutter speed of 1/1000 second or slower. This function may not be combined with some shooting modes.

Lens Aberration Correction and Fringe Compensation*

High-quality image reproduction across the image field, with effective compensation of aberrations

The K-1 effectively compensates for the distortion, vignetting and chromatic aberration caused by specific lens properties, and captures high-quality images with edge-to-edge sharpness. It even compensates for the fringe effect during RAW-data development.

* Available in combination with D FA-, DA-, DA L- and FA-series lenses. However, some of these lenses may not be compatible with these functions.

Fine Sharpness and Extra Sharpness

Sharpness-enhancing tools to greatly improve the image rendition of high-pixel photography

No matter how many pixels and how much resolving power an image sensor may provide, the captured image can appear as a low-resolution image if the subject is outlined with thick lines. The K-1's Fine Sharpness function outlines the subject with thinner, more natural lines than those created by normal processing to produce a high-quality, fine-detailed image. It allows you to create a fine piece of art, with a true-to-life description of the subject. The K-1 also provides an Extra Sharpness function, which emphasizes the subject's outline more prominently with much finer lines, making it particularly useful for enhancing the outline of a low-contrast subject.

Diffraction Correction

Minimizing diffraction blur at small apertures

This function compensates for the drop in resolving power caused by the diffraction during image processing. Based on obtained image data, it provides an exposure compensation of up to approximately two aperture steps,* making it useful for such subjects as landscapes, which requires you to close down the aperture to widen a depth of field without compromising the resolving power.

* Measured under RICOH IMAGING in-house testing standards. This function can be used with D FA-, DA-, DA L-, and FA-series lenses, with an exception of some incompatible lenses.



Diffraction Correction : OFF



Diffraction Correction : ON

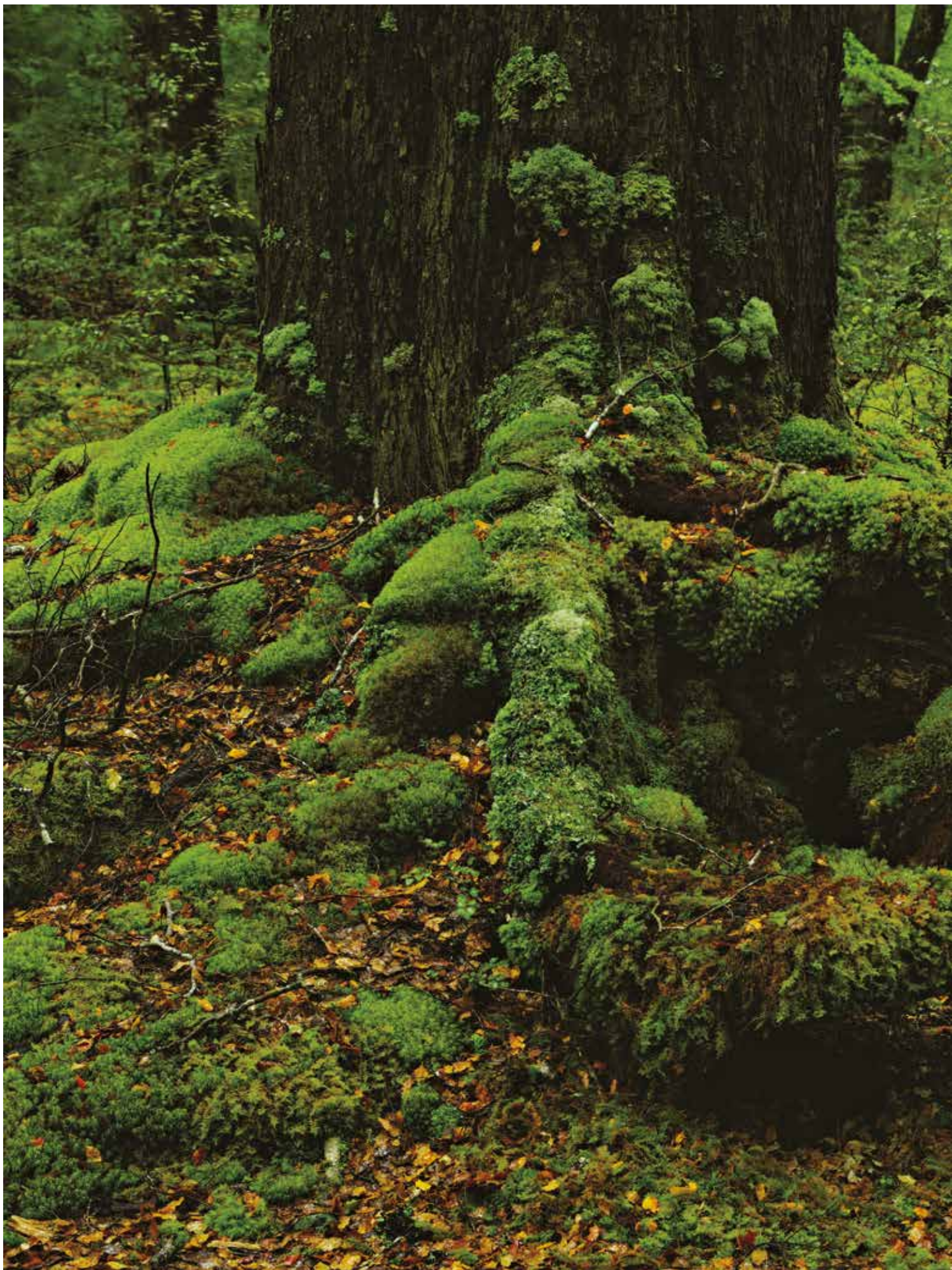

HD PENTAX-D FA 24-70mmF2.8ED SDM WR



SR II in-body shake reduction mechanism **NEW**

The world's first five-axis, five-shutter-step camera shake compensation*

The PENTAX-original sensor-shift-type shake reduction mechanism has been upgraded to provide optimum compensation for all lenses used in handheld shooting. The new-generation SR II (Shake Reduction II) features a five-axis mechanism to compensate for camera shake caused by horizontal and vertical shift** (often generated in macro photography) and camera shake caused by roll, which is difficult to handle by lens-installed shake reduction mechanisms, in addition to more common camera shake caused by pitch and yaw. The SR II unit is controlled with great precision as soon as the camera's power is turned on, and provides a wide compensation range — as much as five shutter steps*** — to expand the limits of handheld shooting.

* For a 35mm full-frame digital SLR camera, as of February 2016 (based on RICOH IMAGING research).
 ** During Live View shooting, this mechanism does not compensate for camera shake caused by horizontally and vertical shift.
 *** Measured in conformity to CIPA standards, using an HD PENTAX-D FA 28-105mm F3.5-5.6ED DC WR lens at a focal length of 105mm.



SR Shake Reduction II

5 axes 5 steps

Shake reduction along five axes

- ① ② Pitch and yaw
- ③ Roll
- ④ ⑤ Horizontal and vertical shift



SR : OFF



SR : ON



SR : OFF



SR : ON

Compatible with panning shots

When taking a panning shot, this mechanism efficiently controls the SR unit to detect only the direction of the camera's movement, while compensating for all other affecting vectors. Because of this, the K-1 captures beautiful, high-resolution images both in normal shooting and panning photography, without requiring any switching operation.

High-precision AE / AF operation at -3EV illumination

Extra-accurate auto-exposure and autofocus control, even in the dark

An illumination level of -3EV makes it difficult to see a subject with the naked eye, and almost impossible to make accurate focus with manual focusing. Even under such low-illumination conditions, the K-1 assures high-precision auto-exposure and autofocus operations.* Thanks to its upgraded algorithm, its autofocus response time for poorly illuminated subjects is greatly reduced. Coupled with its super-high-resolution imaging power, the K-1 delivers exceptional shooting performance in dark locations.

* Light metering measured at ISO 100 and with a 50mm F1.4 lens; focusing measured at ISO 100, at room temperature and with 25 middle sensors.

Outdoor-oriented LCD monitor **NEW**

Single-action setting of LCD monitor's brightness

With a single push of a button, the K-1's new Outdoor View Setting mode displays five brightness settings on its LCD monitor, allowing you to easily and quickly set the desired brightness level for a given location — brightening the monitor under dazzling sunshine or darkening it under starlit skies.



Outdoor View Setting : -2



Outdoor View Setting : +2

Operation Assist Light **NEW**

Supporting camera operations in the dark

Four Operation Assist Lights are strategically positioned around the camera body: at the upper side of the lens mount, behind the LCD monitor, at the memory card slot, and at the cable switch terminal. With a push of the illumination button, you can turn them on* to facilitate lens and memory card changes, control button operations, and attachment and removal of a cable switch, for more efficient, comfortable shooting of nighttime outdoor scenes and poorly lit indoor subjects.

* The LED lights can be switched on and off individually. They are all set to the off mode at default setting.

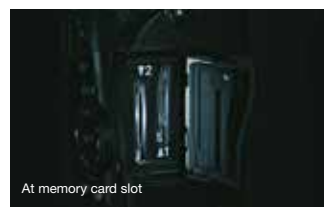
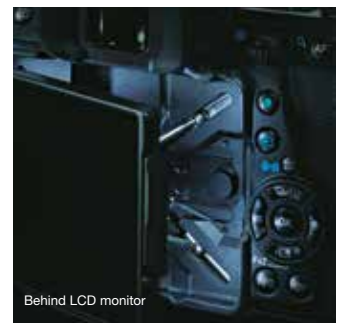

Dependable dustproof, weather-resistant construction

A completely environment-resistant imaging system, with a weather-resistant lens

A combination of the K-1's 87 sealing parts and the optional D-BG6 Battery Grip's watertight body prevents the intrusion of water and dust into their interior. When an AW- or WR-series lens is mounted,* the K-1 and its lens forms a remarkable digital imaging system totally resistant to demanding environmental factors.

* AW stands for All Weather (dustproof and weather-resistant construction), while WR stands for Weather Resistant (simplified weather-resistant construction).



-10°C cold-resistant construction

Unmatched reliability proven under vigorous testing conditions

Anticipating use in cold locations, PENTAX has subjected the K-1 to exacting environmental tests at temperatures as low as -10°C, and gathered a vast array of data on operational precision, response and stability of mechanisms and circuits, as well as fluctuations in battery voltage.* As the result, the K-1 assures solid, trouble-free operation even at freezing temperatures.

Note: Battery performance declines as the temperature goes down. When shooting in cold environments, the user is advised to carry spare batteries and keep them warm by storing them in an inside pocket.



Five-axis, five-step camera shake compensation

The K-1 overcomes challenging field conditions, such as poor weather, darkness and freezing temperatures.

DR II (Dust Removal II) mechanism

Effective removal of foreign particles from the image sensor

Using its piezoelectric element, this innovative mechanism applies ultrasonic vibrations to the optical glass panel placed in front of the image sensor. This effectively removes all dust particles clinging to the image sensor surface, and prevents annoying dust spots from appearing on a captured image.

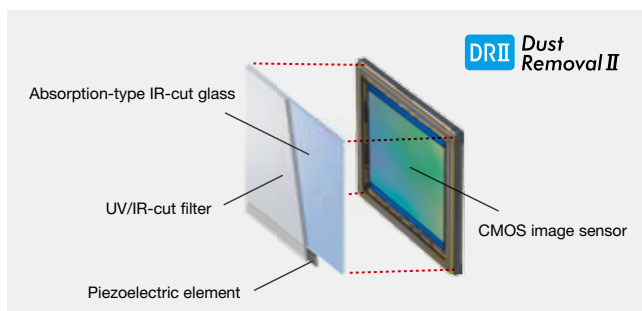

Extra-durable shutter unit **NEW**

Withstanding 300,000 shutter releases for professional use

After a series of exacting performance tests, the K-1's shutter unit has proven its exceptional durability by withstanding a total of 300,000 shutter releases. It assures outstanding operational precision and exceptional durability required for exacting professional work.



High-rigidity, extra-durable body

A shell structure shielding a metallic chassis with a magnesium alloy casing

The K-1's exterior casing is made of highly rigid, lightweight magnesium alloy, which provides excellent shock-resistance and electromagnetic shielding performance. By coupling it with a high-rigidity metallic chassis housing the core components, the K-1 forms a compound structure to assure outstanding durability and exceptional reliability.



Dual card slot

Large-volume image data filing on two SD memory cards

The K-1's card slot accepts two SD memory cards, with a choice of three data filing modes: "Serial" to store a large volume of data successively from one card to another; "Duplicate" (simultaneous filing) for simplified data backup, and "RAW / JPEG Division" to separate data files based on the recording format. It is also possible to copy an image stored on one card to another.



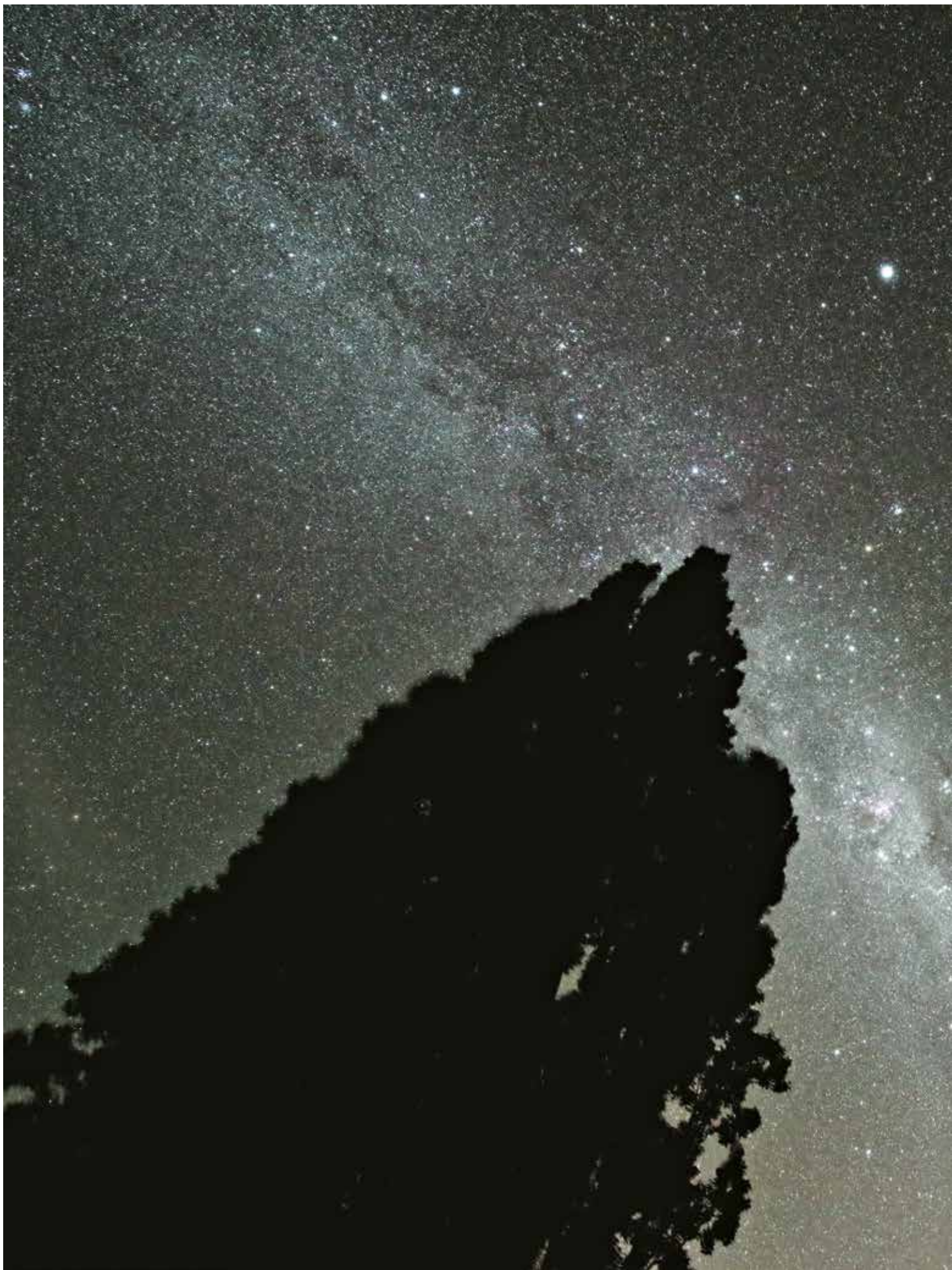

HD PENTAX-D FA 15-30mmF2.8ED SDM WR

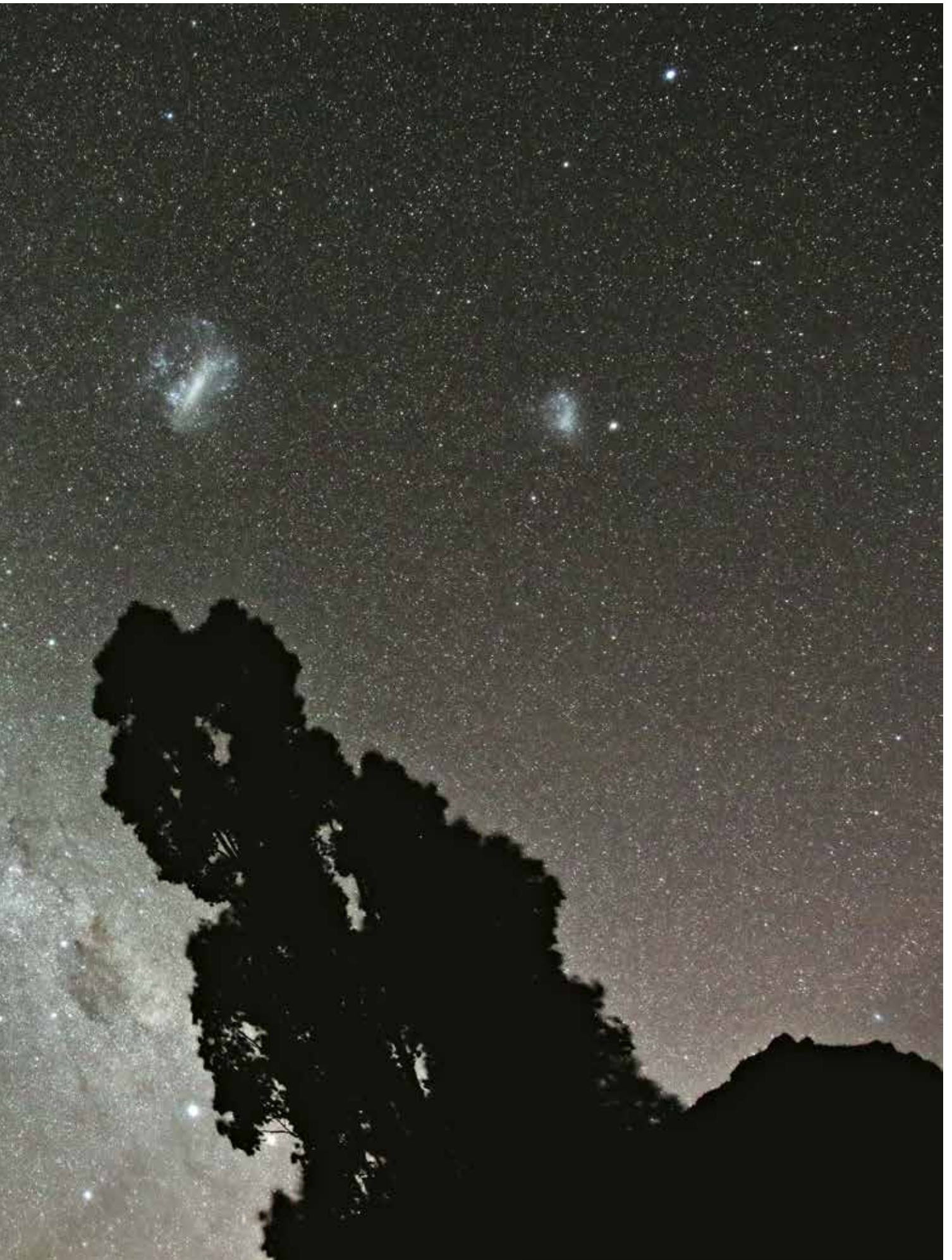

Aperture : F4.0 ; Shutter speed : 60 sec. ; Exposure compensation : 0.0EV ; Sensitivity : ISO 12800 ; White balance : AWB ; Custom image : Natural ; ASTROTRACER



Smart Function **NEW**

Single-action function control

The K-1's Smart Function is a brand-new camera operation system harmonizing an array of features with ease of operation. This functional camera operation system lets you swiftly choose and set the desired function using just two dials positioned on the camera's upper panel, without needing to refer to the menu screen on the LCD monitor.

Functions controllable by Smart Function

Function Dial	Setting Dial
•	Viewfinder shooting: Void Live View shooting: Enlarge display
+/-	Exposure compensation value shift
ISO	ISO sensitivity shift
CH/CL	Switching between Continuous Shooting (with a choice of three drive modes) and Single Frame Shooting
BKT	Bracketing value shift in bracket shooting
HDR	Change of HDR shooting mode
Grid	Viewfinder shooting: ON/OFF Live View shooting: change of grid pattern
SR	Still-image shooting: ON/OFF of SR mechanism Movie recording: ON/OFF of Movie SR mechanism
Crop	Change of Crop setting
Wi-Fi	ON/OFF

Smart Function, GPS functions and ASTROTRACER

Innovative shooting-support features to capture eye-catching masterpieces

Flexible Tilt-Type LCD monitor **NEW**

Innovative mechanism to tilt the monitor to any desired angle along the optical axis

Aiming at aligning the photographer's line of sight precisely with the camera's optical axis while providing a flexible angle adjustment, PENTAX has designed an ideal LCD monitor for the K-1 by creating an innovative mechanism that supports the monitor with four stays. This monitor has reached two difficult goals that conventional monitors have failed to attain: no deviation from the optical axis; and unrestricted tilt in all directions, horizontally or vertically. You can even tilt it up to a nearly 90-degree angle for low-angle and waist-level photography.



Air Gapless LCD monitor

The K-1's Air Gapless LCD monitor uses a special resin layer applied between the protective panel and the LCD screen to effectively cut down internal reflections. Coupled with the Outdoor View Setting function, it assures excellent visibility even under bright sunshine.



Check the video on flexible tilt-type LCD monitor

Built-in GPS module and Electronic Compass

Automatic recording of shooting position data

Electronic Compass

The K-1 features a built-in GPS module and Electronic Compass, which together display the camera's direction on the LCD monitor. These features allow you to attach Exif data to recorded images, including the location, direction and time of shooting (using Universal Time Coordinated). This comes in particularly handy in situations where you must make meticulous preparations in advance for the direction of shooting, such as the shooting of sunrise scenes and celestial bodies.

- 1 Latitude
- 2 Longitude
- 3 Altitude
- 4 Universal Time Coordinated
- 5 GPS signal status
- 6 Camera's direction of shooting (Azimuth)



Electronic Compass screen

GPS Log to track the photographer's movement

The K-1's GPS Log function automatically keeps track of the photographer's movement at fixed intervals. By loading a log file on your computer, you can trace the route you have traveled using a mapping application such as Google Earth™.



Digital level

Accurate detection of camera tilt without removing the eye from the subject

The K-1's Digital Level displays bar scales at the right side and bottom of the viewfinder to indicate the horizontal and vertical tilt of the camera, allowing you to confirm the horizontal and vertical alignment of the subject without taking the eye off the subject. You can also display the Digital Level on the LCD monitor during viewfinder shooting, Live View shooting and movie recording.



Sample of Digital Level display (during Live View shooting)

Live View shooting

An array of creative tools to assist creative photography

In the Live View mode, the K-1 provides a wide range of picture-taking tools. Thanks to its Flexible Tilt-Type LCD monitor, you can clearly view the on-screen image from different angles to optimize shooting comfort.

Main Live View shooting functions

- A selection of AF modes: Face Detection, Auto Tracking, Multi-segment Auto, Select and Spot
- Focus Assist to emphasize the outline of in-focus area
- A choice of grid display from five patterns and two colors (white or black)
- Zoom display with a maximum magnification of 16 times for easy confirmation of focus status

ASTROTRACER

Effortless tracking and photographing of celestial bodies without an equatorial telescope

ASTROTRACER

By making full use of its GPS module, Electronic Compass and SR mechanism, the K-1 simplifies the astronomical photography of celestial bodies, without the help of an equatorial telescope. Based on the latitude data obtained from GPS satellites and other affecting factors (the camera's direction and horizontal / vertical tilt) obtained by its various sensors, the K-1 calculates the movement of celestial bodies, then synchronizes the movement of its image sensor with that of celestial bodies with great precision. Since it captures stars without a streaking effect even during extended exposures, you can record faint stars, which are difficult to detect with the naked eye, as point images.



HD PENTAX-D FA 15-30mmF2.8ED SDM WR

Notes:

- The user is advised to use a tripod to stabilize the camera.
- The user is advised to read the operating manual thoroughly before shooting.
- ASTROTRACER cannot be used with some shooting modes, such as interval shooting and interval composite shooting.

Auto Horizon Correction and Composition Adjustment

Convenient tools to compose well-balanced images

By taking advantage of its SR mechanism, the K-1 helps you compose well-balanced, flawless images. The Auto Horizon Correction function* rotates the image sensor to compensate for the camera's horizontal tilt, making it useful in handheld shooting. The Composition Adjustment function** allows you to make minute adjustment of image composition with a shift of the image sensor. It comes in handy for Live View shooting using a tripod.

- * Maximum compensation angle: approx. $\pm 2^\circ$ (approx. $\pm 1^\circ$ with SR mechanism activated)
- ** Maximum compensation range: $\pm 1.5\text{mm}$ ($\pm 1\text{mm}$ along the axis of rotation) or $\pm 1^\circ$



Optical viewfinder and customization

A well-defined view of the subject and intuitive operation to focus on the subject

Optical viewfinder with a nearly 100% field of view

Assuring a clear view of the field and ease of focus

The K-1's optical viewfinder provides a nearly 100-percent field of view and a 0.7-times magnification to deliver a sharp, crisp view of the subject and a large, well-defined image field, both of which are the benefits of the 35mm full-frame SLR camera. This viewfinder also provides a clear view of the image field free of aberrations, even at the edges. Its Natural-Bright-Matte III focusing screen* makes it easy to identify the in-focus point, even during manual-focus operation.

* The focusing screen is fixed on the camera body, and is not interchangeable.



Transparent viewfinder display NEW

At-a-glance confirmation of the camera's operational status

The K-1's transparent LCD viewfinder display allows you to select desired data, such as a grid display, and monitor it in the viewfinder. It comes in handy when correcting the camera's tilt using the digital level or rearranging the image composition using a grid pattern, without taking the eye off the subject.

Selection of data on viewfinder display

Transparent data to be displayed in the viewfinder (grid pattern, Digital Level, AF frame and spot-metering frame) can be turned on and off independently to accommodate varying shooting conditions and preferred shooting styles.

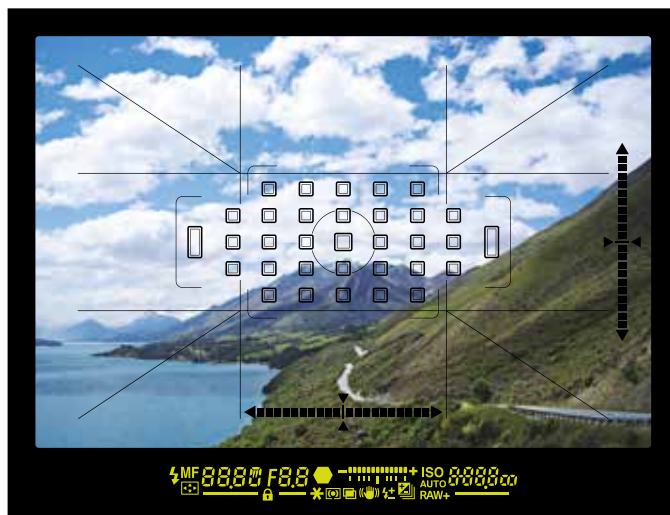

Note: All viewfinder display data, except the crop frame, is simulated to explain the function.

Compact, solid body

Remarkable maneuverability, despite the 35mm full-frame design

The K-1 inherits PENTAX's development concept of a compact body and ease of handling in the field. PENTAX has completely restructured the mechanical unit containing the shutter charge and mirror driving mechanisms, while repositioning the finder unit to keep the camera's height to a minimum. PENTAX's advanced high-density packaging technology has succeeded in creating a compact, maneuverable body for the new K-1.

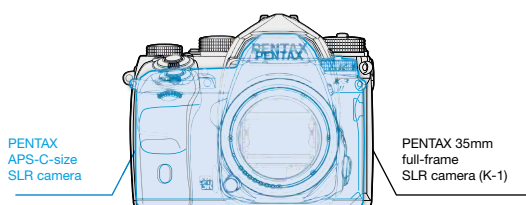

Floating Mirror Structure NEW

In order to accommodate the 35mm full-frame image sensor and the large viewfinder with a nearly 100-percent field of view, it was necessary to increase the size of the main mirror and mirror box. To minimize the size of the mirror box, PENTAX has developed a new mechanism that retracts the main mirror as it swings upwards.

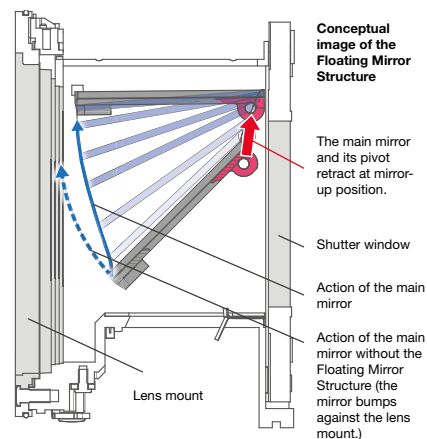



HD PENTAX-D FA 150-450mmF4.5-5.6ED DC AW

Aperture : F6.3 ; Shutter speed : 1/800 sec. ; Exposure compensation : 0.0EV ; Sensitivity : ISO 100 ; White balance : Color temperature assigned ; Custom image : Bright

Customization

Creating your personal K-1 by customizing camera operations to your preference

The K-1 provides a wide range of customization settings to optimize the ease and comfort of camera operations. These settings have been designed to expand the functions of the USER Mode and the Fx (function) buttons, improve accessibility to desired functions on the control panel, and prevent accidental operational errors.

USER Mode

Five different combinations of the most frequently used functions can be assigned to this mode to handle specific subjects or creative intentions.

Control panel **NEW**

This panel displays a list of the functions and their status on the LCD panel, while allowing you to change the contents and/or order of listed functions to suit your shooting style.















Customization buttons

- 1 Fx1 button : One function from seven options can be assigned (default: RAW)
- 2 Fx2 button : Another function from seven options can be assigned (default: Outdoor View Setting)
- 3 AF button : One of the functions governing AF operation can be assigned.
- 4 Preview lever : An optical or digital preview mode can be assigned.
- 5 E-dial + Green button : A set of exposure mode can be assigned.

Lock button **NEW**

In order to prevent accidental setting changes, the K-1 provides a lock button to temporarily inactivate control buttons and dials. It offers you a choice of two lock functions: Type 1 to prevent unintended exposure setting changes; and Type 2 to prevent operational setting changes.

Type	Lockable buttons and dials
Type 1	      
Type 2	     



Custom Functions

A total of 26 Custom Functions are available with the K-1.

Image shooting features

A host of picture-taking functions to capture a decisive moment without failure

PENTAX Real-time Scene Analysis System

Optimizing the performance of AE and AF systems and the ease of image composition

Supported by the approximately 86,000-pixel RGB light-metering sensor and the new PRIME IV imaging engine, the PENTAX Real-time Scene Analysis System analyzes such factors as brightness distribution in the image field, the subject's primary color and its motion with great accuracy and efficiency. In addition, by adopting a breakthrough artificial intelligence technology called deep learning to its image detection algorithm,* this system assesses each individual scene more accurately, while optimizing the accuracy and performance of the light-metering, exposure-control and autofocus systems, and selecting the most appropriate finishing touch for a given scene or composition.

* This RICOH-original technology is available during viewfinder shooting when the exposure mode is set to Scene Analyze Auto and the Custom Image mode is set to Auto Select.

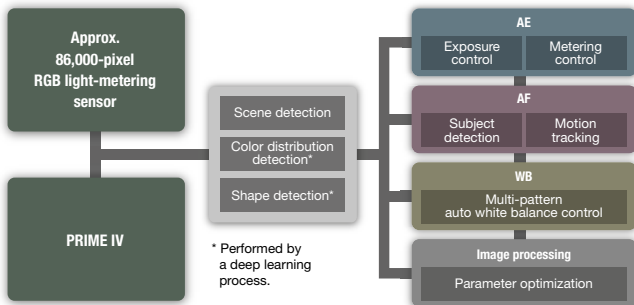

HD PENTAX-D FA 24-70mmF2.8ED SDM WR

Aperture : F3.5 ; Shutter speed : 1/160 sec. ; Exposure compensation : 0.0EV ; Sensitivity : ISO 100 ; White balance : Daylight ; Custom image : Portrait

86,000-pixel RGB light-metering sensor

High-precision scene analysis based on the subject's color, shape and motion

The K-1's approximately 86,000-pixel RGB light-metering sensor not only delivers outstanding resolving power, but also detects colors with great precision. After accurately measuring the subject's shape, primary color and motion, it feeds the obtained data to the PENTAX Real-time Scene Analysis System for extra-accurate scene analysis.

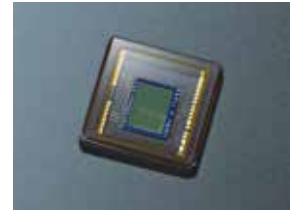

SAFOX 12 NEW

Newly developed AF system, with an expanded AF detection area

The K-1's AF frame has been widened to optimize the ease of image composition over a larger 35mm full-frame image field. Thanks to the development of a new SAFOX 12 AF sensor module, its autofocus area is approximately 40 percent wider than a conventional AF frame.* In order to contain a longer optical path required for the expanded AF area within a compact housing, the K-1 features an innovative, efficient optical design in which the incoming light is turned back within the AF module. Thanks to the optimization of the condenser lens, it also provides an increased number of AF sensor points (33 in total). This state-of-the-art AF module boosts both compact dimensions and exceptional image-forming performance.

SAFOX 12 AF module

This new AF sensor module features two reflex mirrors. By reflecting the incoming light flux twice on these mirrors, it provides a longer optical path, while its overall size has been kept nearly identical to that of SAFOX 11.

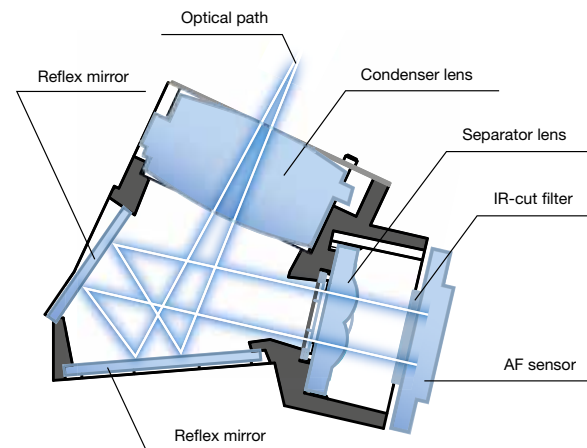

A light source sensor is positioned next to the pentaprism to optimize autofocusing accuracy by compensating for focusing errors caused by specific artificial light sources.



33-point AF system with 25 cross-shaped sensors **NEW**

Assuring reliable, unflinching focus on the subject

The K-1's sophisticated 33-point AF system has a high-density distribution of AF sensors to effectively monitor crucial areas of the image field, while providing 25 cross-shaped sensors to assure extra-accurate focus on the subject.

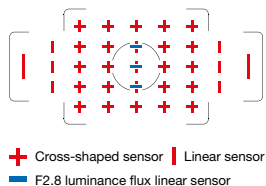

AF system with F2.8 luminance flux linear sensors

Three center sensors are designed to detect the luminance flux of an F2.8 lens for high-precision autofocusing. When using a very fast lens with a shallow depth of field, these sensors can greatly improve the focusing accuracy.

Zone Select

This mode lets you select a set of nine points forming a square, which can be shifted as desired by moving the center point. It detects a subject placed within this square, optimizes the focus, and tracks its movement — all automatically.



Select-area expansion

This mode lets you select one of 33 AF points to focus on the subject, and makes the K-1 automatically track the subject and refocus on it with the help of the neighboring points, even when it moves away from the initial point. You can select the desired expansion area from nine, 25 or 33 points.*

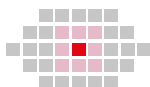

* The number of AF points may decrease if the selected expansion area includes an area or areas outside the AF frame.

Auto tracking with PENTAX Real-time Scene Analysis System

Supported by the PENTAX Real-time Scene Analysis System, the K-1's Auto Tracking function accurately detects the subject's motion based on various factors including color, then keeps pinpoint focus on the subject throughout the imaging process by automatically shifting the in-focus point.

1/8000-second high-speed shutter

Exceptional operational accuracy and remarkable durability

The K-1 features an electronically controlled, vertical-run shutter to optimize the performance of the 35mm full-frame image sensor. With a top speed of 1/8000 second, it allows you to open up the aperture, even in bright locations, and take full advantage of the bokeh (defocus) effect created by the large image sensor. It also provides a flash synchronization speed of 1/200 second. Symbolizing the K-1's field camera concept, this unit is designed to be compact and lightweight, with a well-balanced combination of high-precision operation and outstanding durability.

High-speed drive mode

Flawless continuous shooting at approximately 4.4 images per second

The K-1 provides high-speed continuous shooting at a top speed of approximately 4.4 images per second (at CH setting). You can also switch instantly to an optional speed setting of three images per second (CM) or 0.7 images per second (CL) using the main menu or Smart Function. In the APS-C Crop mode, the drive speed can be boosted to as high as approximately 6.5 images per second to assure quick response to fast-moving subjects.

Large image recording capacity in continuous shooting

A maximum of 100 images captured at a high-quality 36-megapixel level

Thanks to its large-capacity buffer memory, the K-1 lets you record a large number of images during continuous shooting: approx. 70 JPEG images (or approx. 17 RAW images) at CH setting; approx. 100 JPEG images (or approx. 20 RAW images) at CM setting, or approx. 100 JPEG images (or approx. 100 RAW images) at CL setting.*

* These figures are an approximate number of images recordable in the 35mm full-frame format, in the JPEG L-size Best format, and at ISO 100.

Scene Analyze AUTO **NEW**

Much-improved accuracy, through the adoption of artificial intelligence technology

Supported by the PENTAX Real-time Scene Analysis System, the K-1's Scene Analyze AUTO mode automatically optimizes exposure settings, and selects the most appropriate finishing touch for your subject. When using the optical viewfinder, it is also assisted by an algorithm that adopts the deep learning artificial intelligence technology, and makes an extensive analysis of a given scene based on the enormous volume of data accumulated from previous scenes.



Multi-mode AE system

A choice of distinctive auto-exposure modes

In addition to the conventional Program (P), Aperture-Priority (A) and Shutter-Priority (Tv) modes, the K-1 also provides the PENTAX-original Sensitivity-Priority (Sv) and Shutter-speed / Aperture-Priority (TAv) modes, both of which assure proper exposure on the subject by factoring the ISO sensitivity more prominently into exposure-control operation. This multi-mode system assures more flexible control of exposure settings to express the subject's motion or the depth of field. It also provides a wide exposure compensation range of $\pm 5EV$ (in still-image shooting) to expand a range of exposure control.

Hyper Program and Hyper Manual

Flexible control of the depth of field and the subject's motion

In the Program (P) mode, the K-1 features the PENTAX-developed Hyper Program mode, which allows you to set a desired shutter speed and aperture using the front and rear e-dials, while retaining a proper exposure level. This eliminates the need for turning the mode dial when switching to the Tv or Av mode.

Conceptual diagram of Hyper Program mode

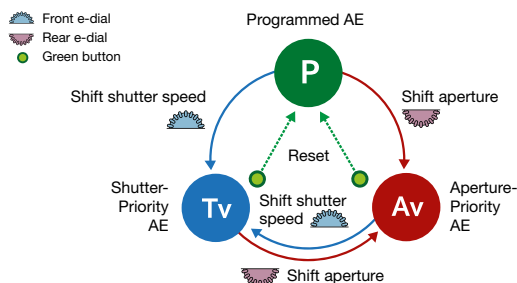

In the Hyper Manual (M) mode, one push of the green button instantly sets the same aperture and shutter-speed settings as those of the P mode for proper exposure. Then, you can adjust the exposure to a desired level using the front and rear e-dials. With the AE-L button, you can even shift aperture and / or shutter-speed settings while retaining the initial exposure level.

Conceptual diagram of Hyper Manual mode

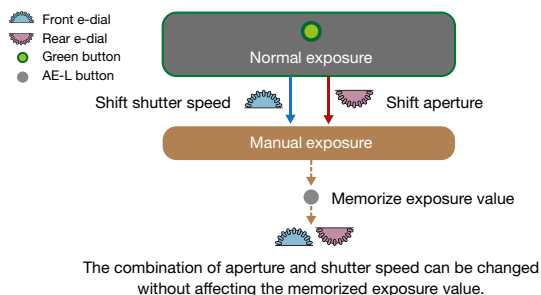

When you set the Smart Function to the ISO mode, you can enjoy more flexible control of the three primary exposure parameters — aperture, shutter speed and ISO sensitivity — in both the P and M modes, using a combination of the front and rear e-dials and the setting dial.

Image composition and shooting functions

For freedom of creativity and boundless inspiration

Custom Image

Effortless expression of the ideal tone and shade for each subject

The K-1's Custom Image function allows you to apply the preferred finishing touch to your image, based on your subject or creative intentions. With the addition of Auto Select, in which the camera automatically detects the type of scene or subject and selects the best finishing touch for you, and Flat, which produces a base image most tolerant to retouching, the K-1 now provides a total of 13 Custom Image modes.* Each mode provides minute adjustment of parameters such as saturation, shade, key, contrast and sharpness.**

* The Custom Image mode is fixed to Auto Select when the camera's exposure mode is set to AUTO.
** Adjustable parameters may vary depending on the selected Custom Image mode.



Flat



Bright

A selection of Custom Image modes

Auto Select NEW	Muted
Bright	Flat NEW
Vibrant	Natural
Radiant	Portrait
Reversal Film	Landscape
Monochrome	Bleach Bypass
Cross Processing	

Clarity control and Skin Tone correction* **NEW**

Compensation of the subject's texture, while retaining the image's overall sharpness

The Clarity control function is an image-processing technology effective in reproducing the glossy texture of metals and the clearness of the sky or splashing water. By adjusting the smoothness of a silky or shiny surface, it lets you control the quality of texture and the degree of clarity. The Skin Tone correction function** restores a tender texture and a healthy tone of the subject's skin, while keeping the high-resolution rendition in its hair and clothing and in the background. It depicts your subject with smooth texture and healthy skin tones.

* Both of these functions are technologies developed by RICOH Co., Ltd.

** The Skin Tone correction function can be activated only when the Face Detection mode is selected.



Clarity:-4



Clarity:0



Clarity:+4



Skin Tone correction: ON



Skin Tone correction: OFF

HDR

Faithful reproduction of highlights and shadows

The K-1's HDR (High Dynamic Range) mode* delivers an image similar to that detected by the naked eye, by minimizing white-washed highlights and pitch-black shadows, even with extreme high-contrast scenes. It also allows you to set a range of exposure shifts or use the Automatic Position Adjustment function.** Since this mode can save original image files in the RAW format, you can develop them by changing HDR settings or turning the HDR mode off. By using a PC and the included software, you can also divide a single RAW-format file into three separate RAW-format images, and save them as independent files.



* This HDR function cannot be used in some shooting modes, and is not compatible with some other functions.
** The Automatic Position Adjustment function is fixed at the OFF mode when the Interval or Interval Movie shooting mode is selected.

Multiple exposure

Three ways to synthesize highly creative images

The K-1 lets you capture the desired number of images — from two to 2,000 — to synthesize a single composite image, with three synthesis modes: average, additive and comparative brightness. In Live View shooting, the K-1 displays a translucent image of the already captured image on its LCD monitor, allowing you to make precise alignment of the images.



Additive mode

Digital filters

For creating a dramatized work of art with special visual effects

The K-1 offers a choice of nine digital filters during shooting, and 21 digital filters during playback. You can apply as many as 20 filters to a single image to create a distinctive, personalized work of art.

CTE

For expressing the colors of the mind, rather than truthful color reproduction

In contrast to the standard auto white balance mode, which is designed to suppress the effect of a light source color on the image's color reproduction, the CTE (Color Temperature Enhancement) mode emphasizes the image's dominant color based on the color temperature. It is useful in dramatizing sunrise and sunset scenes or snow-covered landscapes under the cloudy sky. It is also effective in preventing color fading or the loss of colors such as dark greens and faint pinks.



AWB



CTE



HD PENTAX-D FA 24-70mmF2.8ED SDM WR

Aperture : F8.0 ; Shutter speed : 1/500 sec. ; Exposure compensation : -0.3EV ; Sensitivity : ISO 100 ; White balance : AWB ; Custom image : Landscape

Movie recording

Full HD movies with a beautiful bokeh effect

The K-1 records lively, true-to-life movies. Thanks to a shallow depth of field provided by its 35mm full-frame design, it effectively produces a beautiful bokeh effect. You can also record sound in stereo using a stereo microphone (commercial product, not included with the K-1), or monitor it during recording using headphones (commercial product, not included with the K-1).



4K-compatible Interval Movie shooting

Documenting a constantly changing subject in high resolution

The K-1's Interval Movie mode allows you to record still images of a slowly changing subject at a fixed interval, and link them into a single movie file. You can play back the 4K-resolution (3840 x 2160 pixels) movie file,* as if fast-forwarding the time on the screen. The K-1 also provides the Star Stream function, which lets you draw the magical traces of stars in a movie.

* When playing back the movie file on a device other than the K-1, the user is advised to use a PC operating environment supporting 4K-resolution movie playback.

Wi-Fi compatibility

Remote control of the camera using a smartphone

By wirelessly connecting the K-1 with your smartphone, you can capture images from a distance, or browse them on the smartphone screen.* You can set various shooting functions and change their settings, adjust the focus, release the shutter, and check the captured images.

* The dedicated Image Sync application is required for remote shooting and browsing operations. Image Sync can be downloaded free of charge from App Store (for iPhones) or Google Play™ (for Android™ smartphones).

** Access the RICOH IMAGING official website or contact our customer service center for compatible smartphone operating systems.



IMAGE Transmitter 2 compatibility **NEW**

Tethered photography from a personal computer

By installing the optional IMAGE Transmitter 2 tethering software on your PC and connecting it with the K-1 via USB terminal, you can operate the K-1, automatically transfer and save recorded images, and check photographic data on your computer. This greatly improves the efficiency of studio shooting.

Note: For proper use, the software must be upgraded to the latest version. Please access our official website for details.

In-body RAW data development

Application of the desired finishing touch without a computer

The K-1 provides in-body development of RAW-format files, with the developed files saved as separate JPEG or TIFF files. This offers greater flexibility in finishing a captured image more faithfully to your creative intention, without the help of a PC. Thanks to a wide range of adjustable parameters, you can add a desired finishing touch to your image regardless of a location, until you are truly satisfied with the result. The K-1 also features a newly designed user interface for more effortless, more flexible parameter control.

Exclusive software for high-quality finish and browsing

Digital Camera Utility™ 5

Supported by the acclaimed SILKYPIX® image development engine, this software allows you to browse through captured images and develop them into RAW-format files on a computer. It is compatible with the K-1's new features, including the Flat mode of the Custom Image function and the Motion Correction function of the Pixel Shift Resolution System.



PENTAX K-mount lenses

Exceptional optical performance to deliver well-defined images

The K-1 inherits PENTAX's time-proven K mount. It accepts not only D FA-series lenses optimized for digital imaging, but also FA- and FA Limited-series lenses to accommodate a wide range of creative intentions and applications.

DFA★ DFA High-resolution, high-performance lens series optimized for 35mm full-frame format

D FA*-series lenses are designed for uncompromising optical performance, while D FA-series lenses assure well-balanced imaging power. They effectively compensate for various aberrations even at the edges of the K-1's wide image field, while optimizing resolving power and contrast across the image.



HD PENTAX-D FA **15-30mmF2.8ED SDM WR NEW**

This large-aperture, ultra-wide-angle zoom lens captures a dynamic image of sweeping landscape with its overwhelming perspective. Thanks to its minimal distortion, it is also ideal for photographing starry skies.



HD PENTAX-D FA **24-70mmF2.8ED SDM WR NEW**

With its maximum aperture of F2.8, this large-aperture, standard zoom lens assures remarkable resolving power and rich contrast. It is effective in creating distinctive visual expressions, such as beautiful bokeh and pan-focus effects.



HD PENTAX-D FA **28-105mmF3.5-5.6ED DC WR NEW**

Covering wide-angle to medium-telephoto ranges, this versatile standard zoom lens is perfect for capturing most everyday scenes. Its compact, lightweight design also makes it handy for traveling.



FA Limited

Distinctive lenses to broaden the scope of photography

Compatible with the 35mm full-frame format, these high-grade lenses provide unique focal lengths deduced from the experiences of many professionals and outstanding imaging power with a truthful sense of perspective. Its exterior casing is made of high-grade machined aluminum for a beautiful finish and durability.



SmC PENTAX-FA 31mmF1.8AL Limited

SmC PENTAX-FA 43mmF1.9 Limited



**HD PENTAX-D FA
70-200mmF2.8ED DC AW NEW**

Developed as a new-generation Star-series lens, this large-aperture telephoto zoom lens assures optimal imaging performance to capture every scene or subject faithfully to your creative intention.



**HD PENTAX-D FA
150-450mmF4.5-5.6ED DC AW**

This high-resolution, super-telephoto zoom lens brings a distant subject closer for a dynamic composition, and captures an athlete or wildlife in a sharp, crisp image.



**SmC PENTAX-D FA
MACRO 100mmF2.8 WR**

This high-performance macro lens provides a sufficient working distance and an extremely shallow depth of field, even in life-size macro photography. It allows you to pinpoint the focus on a primary element of the subject.



**SmC PENTAX-D FA
MACRO 50mmF2.8**

Designed for life-size macro photography, this compact, lightweight macro lens can also be used as a compact, large-aperture, unifocal standard lens.



FA Rich gradation and true-to-life color reproduction



SmC PENTAX-FA 77mmF1.8 Limited



SmC PENTAX-FA 35mmF2AL



SmC PENTAX-FA50mmF1.4





DA★ DA Limited DA

All APS-C-format, K-mount interchangeable lenses are usable on the K-1.

From ultra-wide angle to super telephoto, an entire selection of high-performance DA-series lenses can be used on the K-1 without any modification. They deliver exceptional image quality, despite their compact, lightweight design.

Crop mode

Automatic switching of an image area with attachment of a lens

When a DA*, DA Limited- or DA-series lens is mounted on the K-1, its Crop mode automatically switches an image area to the APS-C size covering the middle section of the image field, while displaying the cropping frame in the viewfinder. It not only assures high-resolution images with approximately 15.36 effective megapixels, but also provides an efficient AF sensor coverage of the image area for more flexible image composition during autofocus operation. When you select the FF (Full Frame) setting of the Crop mode, you can even capture a 35mm full-frame image with a DA-series lens.*

* With certain lenses and / or under certain photographic conditions, a captured image may suffer a drastic drop in brightness and / or resolution in the areas outside the APS-C image area. This setting does not provide compensation of various lens aberrations.

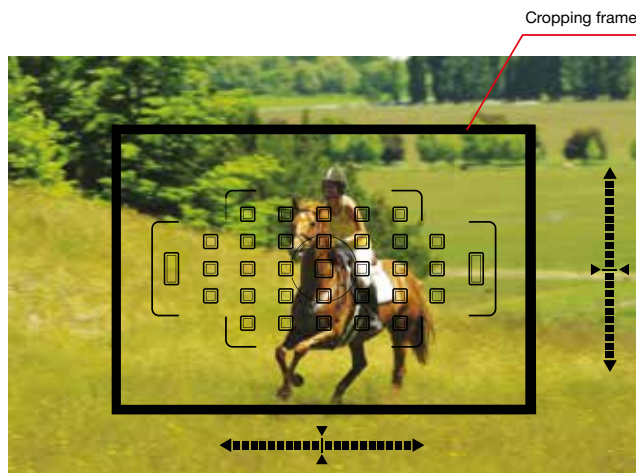

Viewfinder display in the Crop mode (APS-C image area)

Note: This image displays all AF sensors for an explanatory purpose.

DA* / DA Limited / DA Lenses

Fish-eye zoom	SmC PENTAX-DA FISH-EYE10-17mmF3.5-4.5ED(IF)
Ultra-wide-angle zoom	SmC PENTAX-DA 12-24mmF4ED AL(IF)
Standard zoom	SmC PENTAX-DA 16-50mmF2.8ED AL(IF) SDM HD PENTAX-DA 16-85mmF3.5-5.6ED DC WR SmC PENTAX-DA 17-70mmF4AL(IF) SDM HD PENTAX-DA 18-50mmF4-5.6 DC WR RE SmC PENTAX-DA 18-55mmF3.5-5.6AL WR HD PENTAX-DA 20-40mmF2.8-4ED Limited DC WR
Telephoto zoom	SmC PENTAX-DA 50-135mmF2.8ED(IF) SDM SmC PENTAX-DA 50-200mmF4-5.6ED WR HD PENTAX-DA 55-300mmF4-5.8ED WR SmC PENTAX-DA 60-250mmF4ED(IF) SDM
High-magnification zoom	SmC PENTAX-DA 18-135mmF3.5-5.6ED AL(IF) DC WR SmC PENTAX-DA 18-270mmF3.5-6.3ED SDM
Ultra-wide-angle	SmC PENTAX-DA 14mmF2.8ED(IF) HD PENTAX-DA 15mmF4ED AL Limited
Wide-angle	HD PENTAX-DA 21mmF3.2AL Limited
Standard	SmC PENTAX-DA 35mmF2.4AL
Semi-standard	HD PENTAX-DA 40mmF2.8 Limited SmC PENTAX-DA 40mmF2.8 XS
Telephoto	SmC PENTAX-DA 50mmF1.8 SmC PENTAX-DA 55mmF1.4 SDM HD PENTAX-DA 70mmF2.4 Limited SmC PENTAX-DA 200mmF2.8ED(IF) SDM SmC PENTAX-DA 300mmF4ED(IF) SDM
Super-telephoto	HD PENTAX-DA 560mmF5.6ED AW
Standard/Macro	HD PENTAX-DA 35mmF2.8 Macro Limited

Note: The classification, such as wide-angle, standard and telephoto, is based on the angle of view in the Crop mode (APS-C image area).

Lens aberration-compensated DA-series lenses usable in the 35mm full-frame format

The following DA-series lenses cover the 35mm full-frame image area. When the Crop mode is set to FF (Full Frame), the K-1's lens aberration compensation function is extended to cover certain aberrations, such as diffraction, in the 35mm full-frame image area.*

- SmC PENTAX-DA 200mmF2.8ED(IF) SDM
- SmC PENTAX-DA 300mmF4ED(IF) SDM
- HD PENTAX-DA 560mmF5.6ED AW

* Please note that this function does not guarantee the quality of image outside the APS-C image area.

System accessories

For enhanced operability and greater photographic applications



This accessory nearly doubles the K-1's recording capacity, while enhancing holding comfort and operability in vertical-position shooting.



D-BG6 Battery Grip

- AA-battery (lithium or nickel-hydrogen) holder included, in addition to a rechargeable lithium-ion battery holder
- Additional strap lugs to suspend the camera in vertical position
- Dustproof, weather-resistant structure with 47 sealing parts, providing the same level of environmental resistance as that of the K-1 camera body

Equipped with an extra shutter release button and front/rear e-dials, this accessory assures outstanding operability, even during vertical-position shooting.



A high-power, weather-resistant, dustproof flash unit compatible for movie recording

Auto Flash AF540FGZ II



A high-performance dust and weather-resistant flash unit featuring an LED light

Auto Flash AF360FGZ II



Compact, lightweight flash with a dust and weather-resistant construction

Auto Flash AF201FG



Rechargeable Lithium-ion Battery D-LI90

Spare battery



Battery Charger Kit K-BC90

For easy recharging of the D-LI90 battery



AC Adapter Kit K-AC132

Power supply from standard outlets, for extended shooting and playback



Waterproof Remote Control O-RC1

Weather-resistant remote controller. *Battery cannot be replaced.



Cable Switch CS-205

A shutter-release accessory handy for extended exposures



Image transfer software Image Transmitter 2*

Remote camera operation from a computer

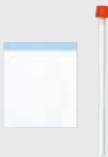

Image Sensor Cleaning Kit O-ICK1

A cleaning stick for quick, easy removal of dust on the image sensor



Strap O-ST1401

General purpose strap made of wide and soft material

* For use with the PENTAX K-1, the IMAGE Transmitter 2 must be upgraded to the latest version. Please access our official website for details.

K-1 System Chart

* There are limitations when combining lenses and accessories. For details, contact your nearest service center.

LENS SYSTEM

D FA lens series, FA/FA J lens series, DA lens series, A lens series, Rear Converter AF Adapter, 67-system lens series, Adapter K for 67-System Lenses, 645-system lens series, Adapter K for 645-System Lenses, S-mount lens series, Mount Adapter K, Spotting Scope, Camera Adapter PF-CA35

Note: D FA645- and DA645-series lenses are not usable with the K-1, except for a D FA645 35mm lens.

INPUT

External microphone (commercial item)

FLASH

AF540FGZ II, AF360FGZ II, AF201FG

FINDER ACCESSORIES

Ref-converter A, Eyecup FT (included), Diopter Correction Lens Adapter M

CLOSE-UP SYSTEM

Interchangeable lens*, Extension Tube Set K, PENTAX FILM DUPLICATOR, Reverse Adapter K

* Cannot be used with the lens without aperture ring.

POWER SOURCES

Rechargeable Lithium-ion Battery D-LI90 (included), Battery Charger D-BC90 (included), AC power cord D-C02 (included), Battery grip D-BG6, AC Adapter K-AC132

OUTPUT

Software S-SW162, Digital Camera Utility5 (included), Image transfer software IMAGE Transmitter2, USB cable Micro B (commercial item), HDMI cable Type D (commercial item), Personal computer, TV

REMOTE CONTROL

Remote Control F, Waterproof Remote Control O-RC1, Cable Switch CS-205

STORAGE MEDIUM

SD/SDHC/SDXC Memory Card (commercial item)

Nomenclature

*Note: Cameras shown without a body mount cap, hot shoe cover and triangle ring.



Viewfinder

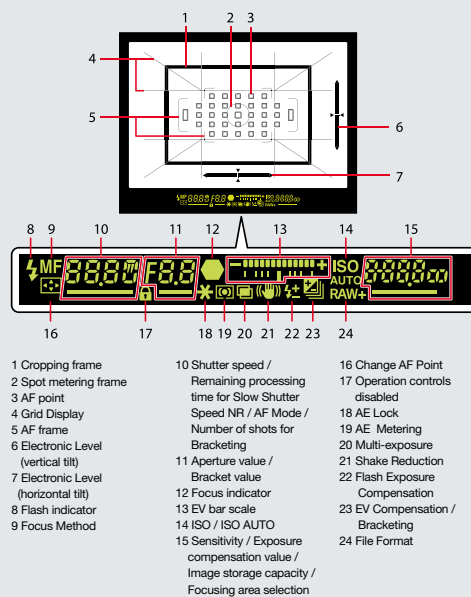

LCD Panel

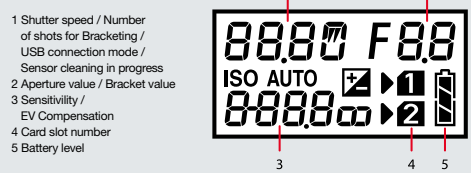

System requirements

The following system requirements must be met in order to connect the PENTAX K-1 to a personal computer, and use the Digital Camera Utility 5 software on the computer.

- [Windows] • OS: Windows 10 (32 bit/64 bit), Windows 8.1 (32 bit/64 bit), Windows 8 (32 bit/64 bit), Windows Vista (32 bit/64 bit)
 • CPU: Intel Core 2 Duo or later • Memory: 4GB or more • Hard disk space: approx. 100MB or more (at installation and start-up); approx. 15MB (JPEG) or 50MB (RAW) per file (for data save) • Monitor: 1280 x 1024 dots or better, 24-bit full-color
- [Macintosh] • OS: Mac OS X 10.10/10.9/10.8/10.7 • CPU: Intel Core 2 Duo or later • Memory: 4GB or more • Hard disk space: approx. 100MB or more (at installation and start-up); approx. 15MB (JPEG) or 50MB (RAW) per file (for data save) • Monitor: 1280 x 1024 dots or better, 24-bit full-color

Note: The operating system must be pre-installed in the computer, and updated to the latest version. The system requirements above do not necessarily guarantee proper operation with all computers.

Storage capacity of 35mm full-frame format (standard)

Recorded pixels	RAW				JPEG					
	(7360×4912)	L:36M(7360×4912)	M:22M(5760×3840)	S:12M(4224×2816)	XS-2M(1920×1280)					
Quality level	PEF	***	**	*	***	**	*	***	**	*
8GB	101	351	676	1164	572	1096	1874	1054	2013	3364

Movie recording capacity (standard)

Recorded pixels	Full HD (1920×1080)				HD (1280×720)	
	60i	50i	30p	25p	60p	50p
8GB	00:32:15	00:38:21	00:32:15	00:38:21	00:39:51	00:32:15

Tested SD/SDHC/SDXC memory cards

[Panasonic/Toshiba/Sandisk] SD memory card capacity: 1 GB, 2 GB SDHC memory card capacity: 4 GB, 8 GB, 16 GB, 32 GB SDXC memory card capacity: 64 GB

[Sandisk] SDXC memory card capacity: 128 GB, 256 GB, 512 GB

* You can record up to 25 min. or 4GB movie for one shooting. * Testing your camera refers to confirmed operation by RICOH IMAGING, and is intended for customer convenience but is not a guarantee by RICOH IMAGING to the customer.
 * Use a high-speed SD memory card when recording movies. If the writing speed cannot keep up with the recording speed, recording may be interrupted.

Specifications

Model Description	Type... TTL autofocus, auto-exposure SLR digital-still camera Lens Mount... PENTAX KAF2 bayonet mount (AF coupler, lens information contacts, K-mount with power contacts) Compatible Lens... KAF3, KAF2 (power zoom compatible), KAF, KA mount lens
Image capture unit	Image Sensor... Primary color filter, CMOS. Size: 35.9 x 24.0 (mm) Effective Pixels... Approx. 36.40 megapixels Total Pixels... Approx. 36.77 megapixels Dust Removal... Image sensor cleaning using ultrasonic vibrations "DR II" Sensitivity (Standard output)... ISO AUTO/100 to 204800 (EV steps can be set to 1EV, 1/2EV or 1/3EV) Image Stabilizer... Sensor-shift shake reduction (SR II: Shake Reduction II)(5-axis) AA Filter Simulator... Moiré reduction using SR unit. OFF/Type1/Type2/Bracket (3 images)
File formats	File format... RAW (PEF/DNG), JPEG (Exif 2.3), DCF2.0 compliant Recorded Pixels... [35mm full-frame] JPEG: L(36M:7360x4912), M(22M:5760x3840), S(12M:4224x2816), XS(2M:1920x1280) RAW: (36M:7360x4912) [APS-C size] JPEG: L(15M:4800x3200), M(12M:4224x2816), S(8M:3456x2304), XS(2M:1920x1280) RAW: (15M:4800x3200) Quality Level... RAW (14bit): PEF, DNG, JPEG: ★★★ (Best), ★★ (Better), ★ (Good), RAW + JPEG simultaneous capturing available Color Space... sRGB, AdobeRGB Storage Medium... SD, SDHC and SDXC Memory Card (Conforms to UHS-I standards) Dual SD slot... Sequential Use, Save to Both, Separate RAW/JPEG, Image copy between slots possible Storage Folder... Folder Name: Date (100_1018,101_1019...) or User assigned folder name (Default +PENTX-) Recording File... File Name: +IMG**** or User assigned file name, File name numbering: Sequential, Reset
Viewfinder	Type... Pentaprism Finder Coverage (FOV)... Approx. 100% Magnification... Approx. 0.70x (50mmF1.4 at infinity) Eye-Relief Length... Approx. 20.6mm (from the view window), Approx. 21.7mm (from the center of lens) Diopter adjustment... Approx. -3.5m to +1.2m ⁻¹ Focusing Screen... Fixed Natural-Bright-Matte III focusing screen Viewfinder Overlay... AF Points, Grid Display, Electronic Level, AF Frame, Spot Metering Frame, Crop
Live view	Type... TTL method using image sensor Focusing Mechanism... Contrast detection (Face detection, Tracking, Multiple AF points, Select, Spot) Focus Peaking: ON/OFF Display... Field of View approx. 100%, Magnified view (up to 16x), Grid Display (4x4 Grid, Golden Section, Scale display, Square 1, Square 2, Grid Color: Black/White), Histogram, Bright area warning, Composition Adjustment
LCD monitor	Type... Wide viewing angle TFT color LCD, Air-gapless glass. Flexible tilt-type. Size... 3.2 inch (aspect ratio 3:2) Dots... Approx. 1037K dots Adjustment... Brightness, Saturation and Colors adjustable Outdoor View Setting... Adjustable ±2 step
White Balance	Type... Method using a combination of the image sensor and the light source detection sensor White Balance... AUTO WB, Multi Auto WB, Daylight, Shade, Cloudy, Fluorescent Light (D:Daylight Color, N:Daylight White, W:Cool White, L:Warm White), Tungsten Light, CTE, Manual WB (up to 3 settings), Color Temperature Configuration (up to 3 settings), Copying the white balance setting of a captured image Fine Adjustment... Adjustable ±7 steps on A-B axis or G-M axis
Autofocus System	Type... TTL: Phase-matching autofocus Focus Sensor... SAFOX 12, 33 point (25 cross type focus points in the center) Brightness Range... EV-3 to 18 (ISO 100 / or normal temperature) AF mode... Single AF (AF.S), Continuous AF (AF.C) AF Point Selection... Spot, Select, Expanded Area (S, M, L), Zone select, Auto (33 AF points) AF Assist Light... Dedicated LED AF assist light
Metering	Type... TTL open aperture metering using 86K pixel RGB sensor, Multi-segment, Center-weighted and Spot metering Metering Range... EV-3 to 20 (ISO100 at 50mm F1.4) Exposure Mode... Scene Analyze Auto, Program, Sensitivity Priority, Shutter Priority, Aperture Priority, Shutter & Aperture Priority, Manual, Bulb, Flash X-sync Speed, USER1, USER2, USER3, USER4, USER5 EV Compensation... ±5EV (1/2EV steps or 1/3EV steps can be selected) AE Lock... Button type (timer type: two times the meter operating time set in Custom Setting); Continuous as long as the shutter button is halfway pressed
Shutter	Type... Electronically controlled vertical-run focal plane shutter * Electronic shutter when using Pixel Shift Resolution Shutter Speed... Auto:1/8000 to 30 sec., Manual:1/8000 to 30 sec. (1/3EV steps or 1/2EV steps), Bulb
Drive modes	Mode Selection... [Still Image]: Single Frame, Continuous (H, M, L), Self-timer (12s, 2s, Continuous), Remote Control (0s., 3s., Continuous), Bracketing (2, 3 or 5 frames), Mirror-up (Possible to use with Remote Control), Multi-Exposure (Possible to use with Continuous, Self-timer or Remote Control), Interval Shooting, Interval Composite, Interval Movie Record, Star Stream [Movie];Remote Control * Bracketing, Interval Shooting, Interval Composite, Interval Movie Record and Star Stream are possible to use with Self-timer/Remote Control. Continuous Shooting... [35mmfull-frame] Max. approx. 4.4 fps, JPEG (L:★★★at Continuous H); up to approx. 70 frames, RAW: up to approx. 17 frames, Max. approx. 3.0 fps, JPEG (L:★★★at Continuous M); up to approx. 100 frames, RAW: up to approx. 20 frames, Max. approx. 0.7 fps, JPEG (L:★★★at Continuous L); up to approx. 100 frames, RAW: up to approx. 100 frames [APS-C size] Max. approx. 6.5 fps, JPEG (L:★★★at Continuous H); up to approx. 100 frames, RAW: up to approx. 50 frames, Max. approx. 3.0 fps, JPEG (L:★★★at Continuous M); up to approx. 100 frames, RAW: up to approx. 1.0 fps, JPEG (L:★★★at Continuous L); up to approx. 100 frames, RAW: up to approx. 100 frames *Continuous shooting frame under ISO100 Multi-Exposure... Composite Mode(Additive/Average/Bright) Number of Shots(2 to 2000 images) Interval Shooting... [Interval Shooting] Interval: 2s. to 24h./ Standby Interval: Min.*1s. to 24h., Number of shots: 2 to 2000 images, Start Interval: Now/Self-timer/Remote Control/Set Time [Interval Composite] Interval: 2s. to 24h./ Standby Interval: Min.*1s. to 24h., Number of shots: 2 to 2000 images, Start Interval: Now/Self-timer/Remote Control/Set Time, Composite Mode: Additive/Average/Bright, Save Process: On/Off [Interval Movie] Recorded Pixels: 4K/FullHD/HD, File Format: Motion JPEG (AVI), Interval:2s. to 24h./ Standby Interval: Min*1s. to 24h., Number of shots: 8 to 2000 images (8 to 500 images at 4K), Start Interval:Now/Self-timer/Remote Control/Set Time [Star Stream] Recorded Pixels: 4K/FullHD/HD, File Format: Motion JPEG (AVI), Interval: Min 1s. to 24h., Number of shots: 8 to 2000 images (8 to 500 images at 4K), Start Interval: Now/Self-timer/Remote Control/Set Time, Fade-out: Off/Low/Medium/High
External Flash	Flash Modes... Auto Flash Discharge, Auto Flash + Red-eye Reduction, Flash On, Flash On + Red-eye Reduction, Slow-speed Sync, Slow-speed Sync + Red-eye, P-TTL, Contrast-control-sync, High-speed sync, Wireless sync * Contrast-control-sync and High-speed sync requires 2 or more dedicated external flash Sync Speed... 1/200sec. Flash Exposure Compensation... -2.0+1.0EV
Capture Settings	Custom Image... Auto Select, Bright, Natural, Portrait, Landscape, Vibrant, Radiant, Muted, Flat, Bleach Bypass, Reversal Film, Monochrome, Cross Processing Cross Process... Random, Preset 1-3, Favorite 1-3 Digital Filter... Extract Color, Replace Color, Toy Camera, Retro, High Contrast, Shading, Invert Color, Unicolor Bold, Bold Monochrome Clarity... Adjustable ±4 Skin Tone... Type1/Type2 HDR... Auto, HDR1, HDR2, HDR3, Advanced HDR, Exposure bracket value adjustable, Automatic composition correction function Pixel Shift Resolution... Available, Motion Correction On/OFF Lens Correction... Distortion Correction, Peripheral Illumin. Correction, Lateral Chromatic Aberration Correction, Diffraction Correction D-RANGE Compensation... Highlight Correction, Shadow Correction Noise Reduction... Slow Shutter Speed NR, High-ISO NR GPS... GPS Logging (Logging Interval, Logging Duration, Memory Card Options), GPS Time Sync Electronic Compass... Available Astrotracer... Possible Horizon Correction... SR On: correction up to 1 degrees, SR Off: correction up to 2 degrees Composition Adjustment... Adjustment range of ±1.5mm up, down, left or right (1mm when rotated); Rotating range of 1 degree Electronic Level... Displayed in viewfinder (Horizontal and vertical); Displayed on LCD monitor (Horizontal and vertical)
Movie	File Format... MPEG-4 AVC/H.264 (MOV) Recorded Pixels... Full HD(1920x1080, 60i/50i/30p/25p/24p) HD (1280x720, 60p/50p) Sound... Built-in stereo microphone, external microphone (Stereo recording compatible) Recording Sound Level adjustable, Wind Noise Reduction Recording Time... Up to 25 minutes or 4GB ; automatically stops recording if the internal temperature of the camera becomes high. Custom Images... Auto Select, Bright, Natural, Portrait, Landscape, Vibrant, Radiant, Muted, Flat, Bleach Bypass, Reversal Film, Monochrome, Cross Processing Cross Processing... Random, Preset 1-3, Favorite 1-3. Digital Filter... Extract Color, Replace Color, Toy Camera, Retro, High Contrast, Shading, Invert Color, Unicolor Bold, Bold Monochrome
Playback	USER Mode... Up to 5 settings can be saved Custom Functions... 26 items Mode Memory... 16 items Button Customization... Fx1 Button, Fx2 Button (One Push File Format, Outdoor View Setting, Flash Mode, Pixel Shift Resolution, Shake Reduction, Horizon Correction, Electronic Level) AF Button (AF1/ AF2/ Cancel AF) Preview Dial (Optical Preview/Digital Preview) Various settings for the action of the e-dials in each exposure mode can also be saved. AF Customization... [AF.S]: Focus-priority/ Release-priority [1st Frame Action in AF.C]: Release-priority/Auto/Focus-priority [Action in AF.C Continuous]: Focus-priority, Auto, FPS-priority [Hold AF Status]: OFF, Low, Medium, High [AF in Interval Shooting]: Locks focus at 1st exposure, Adjusts focus for each shot [AF with Remote Control]: Off/On Operation Control Lock... [Type1]: E-Dial, EV Compensation, ISO, Green Button, AE Lock [Type2]: 4-way controller, Change AF Point/Card slot switch button OK Button, Menu Button Text Size... Standard, Large World Time... World Time settings for 75 cities (28 time zones) Language... English, French, Germany, Spanish, Portuguese, Italian, Dutch, Danish, Swedish, Finnish, Polish, Czech, Hungarian, Turkish, Greek, Russian, Korean, Traditional Chinese, Simplified Chinese, Japanese AF Fine Adjustment... ±10 step, Uniform adjustment, Individual adjustment (up to 20 can be saved) Illumination Settings... LCD Panel (High/Low/Off), Backside Controls (High/Low/Off), Lens Mount (On/Off), Card Slot/Connector (On/Off) Indicator Lamps... Wi-Fi (High/Low/Off), GPS (High/Low/Off), Self-timer (On/Off), Remote Control (On/Off) Copyright Information... Names of «Photographer» and «Copyright Holder» are embedded to the image file. Revision history can be checked using the provided software.
Customization	USER Mode... Up to 5 settings can be saved Custom Functions... 26 items Mode Memory... 16 items Button Customization... Fx1 Button, Fx2 Button (One Push File Format, Outdoor View Setting, Flash Mode, Pixel Shift Resolution, Shake Reduction, Horizon Correction, Electronic Level) AF Button (AF1/ AF2/ Cancel AF) Preview Dial (Optical Preview/Digital Preview) Various settings for the action of the e-dials in each exposure mode can also be saved. AF Customization... [AF.S]: Focus-priority/ Release-priority [1st Frame Action in AF.C]: Release-priority/Auto/Focus-priority [Action in AF.C Continuous]: Focus-priority, Auto, FPS-priority [Hold AF Status]: OFF, Low, Medium, High [AF in Interval Shooting]: Locks focus at 1st exposure, Adjusts focus for each shot [AF with Remote Control]: Off/On Operation Control Lock... [Type1]: E-Dial, EV Compensation, ISO, Green Button, AE Lock [Type2]: 4-way controller, Change AF Point/Card slot switch button OK Button, Menu Button Text Size... Standard, Large World Time... World Time settings for 75 cities (28 time zones) Language... English, French, Germany, Spanish, Portuguese, Italian, Dutch, Danish, Swedish, Finnish, Polish, Czech, Hungarian, Turkish, Greek, Russian, Korean, Traditional Chinese, Simplified Chinese, Japanese AF Fine Adjustment... ±10 step, Uniform adjustment, Individual adjustment (up to 20 can be saved) Illumination Settings... LCD Panel (High/Low/Off), Backside Controls (High/Low/Off), Lens Mount (On/Off), Card Slot/Connector (On/Off) Indicator Lamps... Wi-Fi (High/Low/Off), GPS (High/Low/Off), Self-timer (On/Off), Remote Control (On/Off) Copyright Information... Names of «Photographer» and «Copyright Holder» are embedded to the image file. Revision history can be checked using the provided software.
Playb GPS/ Electronic Compass	Satellites... GPS, QZSS, SBAS(WAAS/EGNOS/GAGAN/MSAS) Reception Frequency... L1 1575.42MHz Recorded Information... Latitude, Longitude, Altitude, Time (UTC), Direction Geodesics... World Geodetic System (WGS84) GPS Logging... KML format, Logging Interval: 5/10/15/30sec./1min., Logging Duration: 1-24hr (Up to 9hours at Logging Interval 5sec. Up to 18hrs. at Logging Interval 10sec.) Electronic Compass... Azimuth calculation using triaxial geomagnetic sensor and triaxial acceleration sensor, True north standard
Power supply	Battery Type... Rechargeable Lithium-ion Battery D-LI90 AC Adapter... AC Adapter Kit K-AC132 (Optional) Battery Life... Number of recordable images: Approx.: 760 images Playback time: Approx. 390 minutes * With a fully-recharged Rechargeable Lithium-ion Battery, 23°C. Tested in compliance with CIPA standard. Actual results may vary depending on the shooting condition.
Interfaces	Connection Port... USB2.0 (micro B), External power supply terminal, External cable switch terminal, X-sync socket, HDMI output terminal (Type D), Stereo microphone input terminal, Headphone terminal USB Connection... MSC/PTP
Wireless LAN	Standards... IEEE 802.11b/g/n Frequency (Center Frequency)... 2412MHz-2462MHz (1ch-11ch) Security... Authentication: WPA2, Encryption: AES
Dimensions and Weight	Dimensions... Approx. 136.5mm (W) x110mm (H) x 85.5mm (D) (excluding protrusions) Weight... Approx. 1010g (Including dedicated battery and SD Memory Card), Approx. 925g (body only)
Operating Environment	Temperature... -10°C-40°C (14°F-104°F) Humidity... 85% or less (no condensation)
Accessories	Included... Strap O-ST162, ME Viewfinder Cap, Rechargeable Lithium-ion Battery D-LI90, Battery Charger D-BC90, AC plug cord, Software (CD-ROM) S-SW162 <Mounted to the camera> Eyecup FT, Hot shoe cover FK, Sync socket 2p cap, Body mount cap KII, Battery Grip terminal cover Software... Digital Camera Utility 5

PENTAX's SLR camera history: the heritage of a field camera



When photographing outdoors, it is desirable that a camera is designed to be small, lightweight and highly resistant to the harsh natural environment.

Since the time of film-format cameras, PENTAX has developed a series of compact, lightweight and durable SLR cameras, and delivered numerous "field camera" masterpieces to our users. Among them are 67- and 645-series medium-format cameras, which have received tremendous support from both professionals and amateurs because of their remarkable maneuverability and exceptional imaging power. As for 35mm film-format cameras, the

professional-standard PENTAX LX remained a best-selling camera for more than 20 years, as the first PENTAX SLR camera to feature a dustproof, weather-resistant structure. Then, the PENTAX ME became an epoch-making model for its world's smallest, lightest body.*

Even after the transition to digital imaging, the PENTAX *ist D — our first digital SLR camera — boosted the world's smallest, lightest body.* The PENTAX K10D and 645D, both of which were named triple-crown winners of the world's most prestigious camera awards, greatly expanded

physical boundaries of outdoor photography with their exceptional dustproof, weather-resistant and cold-proof performance.

Now, equipped with an array of innovative features useful in outdoor photography, the PENTAX K-1 is expected to broaden the potential of field photography, especially in such applications as landscape photography.

PENTAX's heritage as a leading field camera manufacturer will continue into the future.

* The world's smallest, lightest body based on RICOH IMAGING research.



PENTAX K-1 SPECIAL WEBSITE
www.pentax.com/en/k-1



- SDXC logo is a trademark of SD-3C, LLC.
- SILKYPIX® is a registered trademark of Ichikawa Soft Laboratory.
- This product supports PRINT Image Matching III. PRINT Image Matching enabled digital still cameras, printers and software help photographers to produce images more faithful to their intentions. Some functions are not available on printers that are not PRINT Image Matching III compliant.
- All copyrights regarding PRINT Image Matching, PRINT Image Matching II and PRINT Image Matching III are reserved by Seiko Epson Corporation.
- This product includes DNG technology under license by Adobe Systems Incorporated. The DNG logo is either a trademark or registered trademark of Adobe Systems Incorporated in the United States and/or other countries.
- Windows and Windows Vista are registered trademarks of Microsoft Corporation in the United States and other countries.
- Intel Core 2 Duo is a trademark of Intel Corporation in the U.S. and/or other countries.
- Macintosh, OS X, App Store, iPad, Apple, and Apple logo are trademarks of Apple Inc.
- IOS is a trademark or registered trademark of Cisco in the U.S. and other countries and is used under license.
- Android, Nexus, Google Play, and Google Earth are trademarks of Google, Inc.
- HDMI, the HDMI Logo and High-Definition Multimedia Interface are either trademarks or registered trademarks of HDMI Licensing LLC.
- All other brands and product names are trademarks or registered trademarks of their respective companies.

ATTENTION  In order to use PENTAX products properly and safely, you are strongly advised to read the operating manuals carefully and thoroughly before use.

- Images taken with this product that are for anything other than personal enjoyment cannot be used without permission according to the right as specified in the Copyright Act. Users are advised to take care, as there are cases where limitations are placed on taking pictures even for personal enjoyment during demonstrations, performances or items on displays. Images taken with the purpose of obtaining copyrights also cannot be used outside the scope of use of the copyright as laid out in the Copyright Act, and care should be taken here also.
- The liquid crystal panel used for the monitor is manufactured using extremely high precision technology. Although the level of the functioning pixel is 99.99% or better, you should be aware that 0.01% or fewer of the pixels may not illuminate or may illuminate when they should not. However, this has no effect on the recorded image.
- This product is a Class B information technology device that conforms to the standards prescribed by The Voluntary Control Council for Interference by Information Technology Equipment (VCCI) in Japan. Although it is primarily designed and manufactured for use in the household environment, it may cause some electromagnetic interference to radio and TV receivers. Users are advised to follow the instructions described in the operating manual.
- Users are advised to carry spare batteries for extended shooting sessions.
- Images appearing in the LCD monitor are simulated.
- Due to certain qualities of the printing process, there may be some discrepancies in color between the actual product and product images appearing in this brochure.
- Users are advised to check the product serial number upon their purchase.
- Designs and specifications are subject to change without notice.
- The contents of this brochure are all copyrighted, and must not be used, duplicated or transmitted, whether in part or in entirety, without permission. This brochure is produced for personal, noncommercial use only, and must not be used for any purpose other than its intended use.

RICOH
imagine. change.

RICOH IMAGING EUROPE S.A.S.
Parc Tertiaire SILIC • 7-9, avenue Robert Schuman
B.P. 70102 • 94513 RUNGIS CEDEX • FRANCE
www.ricoh-imaging.eu