

PENTAX[®]

SUPER PROGRAM

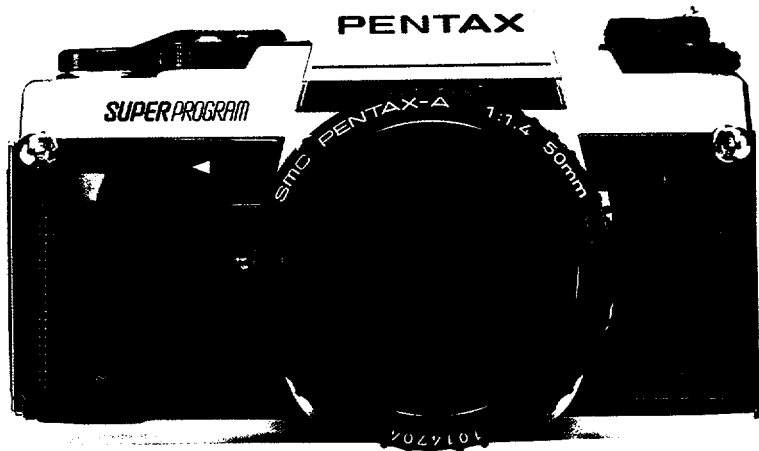

Welcome to the World of Pentax Multi-mode Photography

Pentax Super Program is an ultra-sophisticated 35mm SLR. Incorporating the latest electronics technology, it invites you to explore the possibilities of six different exposure modes. As the situation demands you can use Programmed AE (Automatic Exposure), Aperture-priority AE, Shutter-priority AE, Metered Manual, TTL Automatic Flash or Programmed Auto Flash. In each mode, all the exposure information you need is digitally displayed in the viewfinder by means of an LCD or Liquid Crystal Display.

You can enjoy the full versatility of the Super Program with a wide range of Pentax accessories including dedicated TTL automatic flash units, a motor drive that shoots up to approx. 3.5 frames per second, a digital data back, etc.

Since the Super Program has a great many special features and functions, take the time to read this manual carefully. It will help you take full advantage of an extraordinary camera.

DESCRIPTION OF PARTS

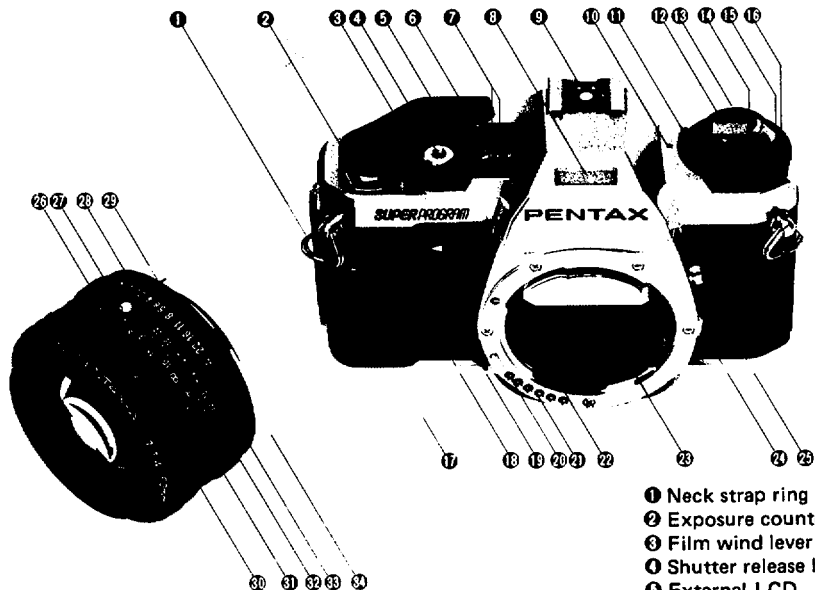

- ① Neck strap ring
- ② Exposure counter
- ③ Film wind lever
- ④ Shutter release button
- ⑤ External LCD
- ⑥ Shutter dial lock release

- ⑦ Manual shutter speed select buttons
- ⑧ Illuminating window
- ⑨ Hotshoe
- Ⓛ Exposure compensation index mark
- Ⓜ Exposure compensation scale
- Ⓝ Film rewind knob/Back cover release knob
- Ⓟ ISO film speed scale
- Ⓠ Film rewind crank
- Ⓡ Film speed dial lock button
- Ⓢ Film speed dial/Exposure compensation dial
- Ⓣ Grip Super A
- Ⓤ Self-timer lever
- Ⓥ Lens release lever
- Ⓦ Preview lever
- Ⓧ Lens information contacts
- Ⓨ Lens alignment index
- Ⓩ Instant return mirror
- ⓐ Lighting button for viewfinder LCDs
- ⓑ X-synch terminal
- ⓓ Distance scale
- ⓔ Lens alignment node
- ⓕ Aperture scale
- ⓖ "A" index on aperture scale
- ⓗ Focusing ring
- ⓘ Depth-of-field scale
- Ⓤ Aperture/Distance index
- Ⓦ Aperture ring
- Ⓧ Aperture auto lock button

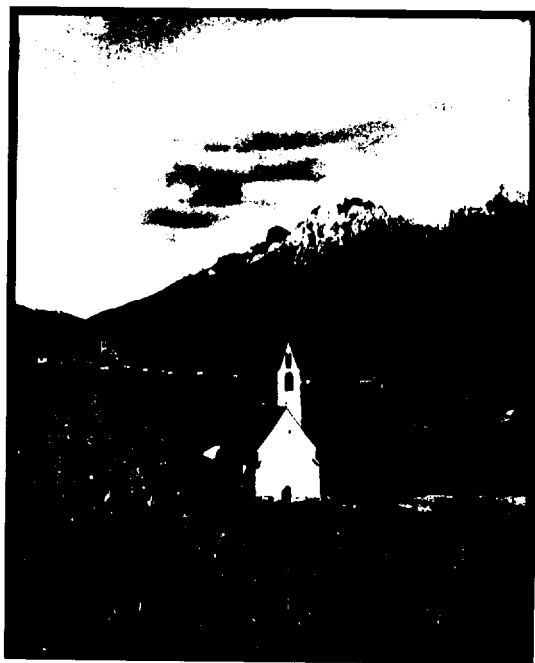

CONTENTS

The Super Program in 9 easy steps.....	2	Selecting the Metered Manual mode	38
Inserting batteries	6	Using Pentax dedicated auto flash units	40
Using batteries correctly	8	Selecting the TTL Auto Flash mode	42
Grip Super A	9	Selecting the Programmed Auto Flash mode	43
Strap and case	10	Programmed AE diagram, Shutter/Aperture coupling range, Meter coupling range	44
Lens mounting	11	Exposure compensation	46
Film wind lever	12	Depth-of-field	48
Shutter dial, shutter release button and release button lock	13	Depth-of-field preview	49
Setting ISO film speed, Memo Holder/Grip	15	Tripod, B (Bulb) and Time exposures	52
Film loading	16	Self-timer	53
Viewfinder displays	18	Use of non-dedicated flash units	54
Focusing	21	Diopter adjustment, changing back cover	55
Holding the camera	22	Infrared index mark	56
Unloading the film	23	Using screw-mount Takumar lenses	57
Six exposure modes	24	How to use various accessories with your Super Program	58
Pentax "A" lens	28	Q & As on your Pentax Super Program	59
Shutter dial, Manual shutter speed select button	29	Camera maintenance	60
Warning indication for each exposure mode	30	Resistance to temperature extremes and changes, A few notes on the LCD (Liquid Crystal Display)	61
Selecting the Programmed AE mode	32	Specifications	62
Selecting the Aperture-priority AE mode	34	Warranty policy	64
Selecting the Shutter-priority AE mode	36		

THE SUPER PROGRAM IN 9 EASY STEPS

Follow the 9 steps below, and in a very short time you'll be able to take pictures with the Super Program in its Programmed AE mode. For more details about each step, consult the accompanying page numbers.

* Remove the cap from the viewfinder eyepiece.

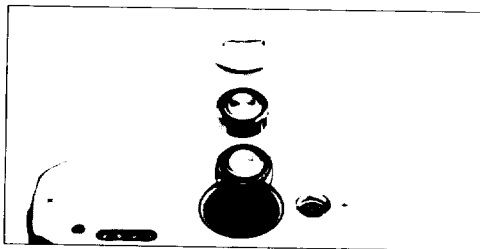

1. Open the battery compartment with a coin and insert batteries. (p. 6)

2. Open the camera back, put in a roll of film, close the back and advance the film to the first frame. (p. 16)

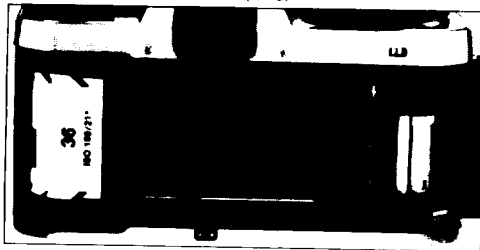
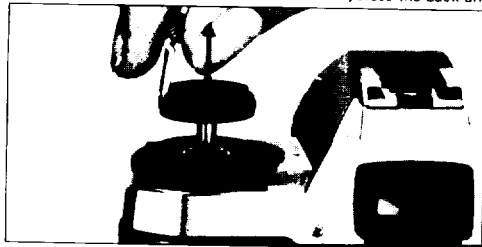

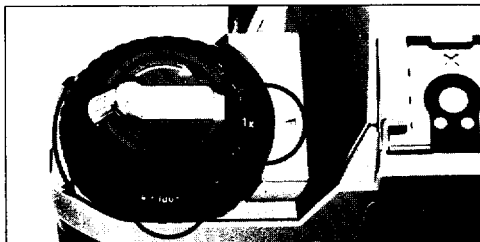

3. Set the ISO film speed to the appropriate number. (p. 15)
Set the exposure compensation dial to 1x. (p. 46)

5. Set the shutter dial to Auto. With both lens and shutter on Auto, the camera is now in the Programmed AE mode. (p. 32)

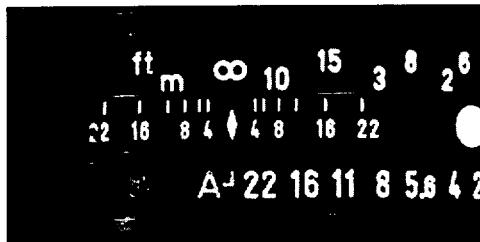
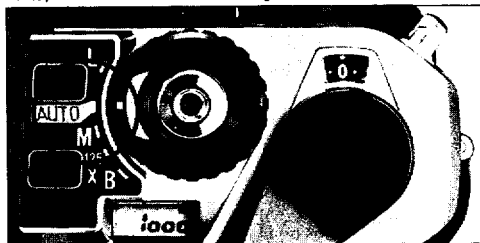

4. Rotate the aperture ring on your "A" series lens to the Auto position (indexed in green), while depressing the aperture auto lock button. (p. 28)

6. Gently press the shutter release button. You will see both shutter speed and aperture setting indicated on the viewfinder LCD and on the external shutter speed LCD. (p. 32)

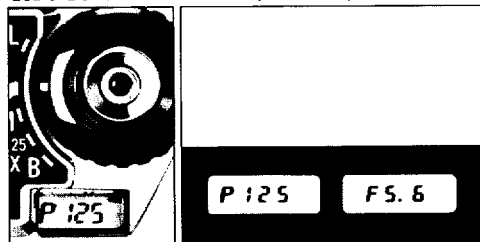



7. Focus the lens by rotating the focusing ring. (p. 21)



8. Make sure that the LCD shows a shutter speed faster than 1/60 second. With slower speeds, camera shake may cause blurred pictures. If the speed is 1/60 or faster, release the shutter.

9. After taking the last picture on the roll, push the film rewind button, rewind the film and remove it from the camera. (p. 23)

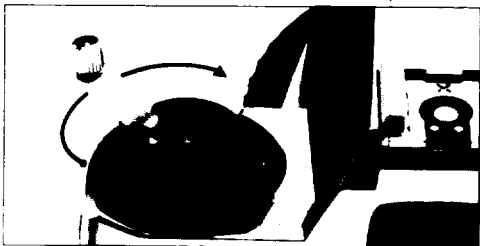
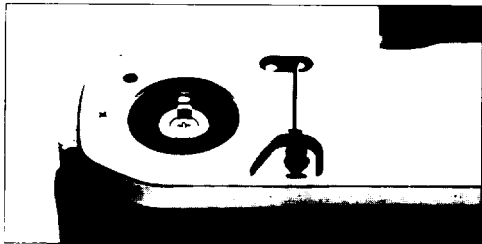

OPERATING INSTRUCTIONS

Please refer to pages 32 ~ 43 for detailed information on the Super Program six exposure modes.

- Programmed AE mode
- Aperture-priority AE mode
- Shutter-priority AE mode
- Metered Manual mode
- TTL Auto Flash mode
- Programmed Auto Flash mode

INSERTING BATTERIES

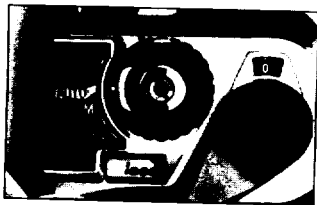
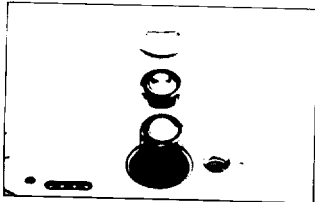

Your Super Program doesn't operate without batteries. Use two 1.5V silver or alkaline batteries, or a 3V lithium battery. Before inserting batteries in the battery compartment, wipe them with a clean dry cloth.

- Open the battery compartment cover with a coin or similar object.
- Place the two batteries in the compartment with '+' marks downward, and close the cover.

Battery check

To confirm battery status, set the shutter dial to AUTO or M and slightly depress the shutter release button to activate the metering system. If the LCDs on the camera top and in the viewfinder indicate shutter speed information, the batteries are properly inserted and sufficient in voltage for normal camera functioning.

Note: The shutter speed LCD will indicate "1000" until the exposure counter registers "0". This fast speed saves time when advancing film to the first frame. Starting with the first frame on the counter, the LCD provides proper shutter speed and aperture value according to the designated exposure mode.

Automatic power cut-off

As an energy-saving measure, a timer switch is integrated into the exposure meter circuit. It automatically shuts off power approximately 30 sec. after you take your finger off the shutter release button.

Low battery warning

When batteries become weak, the display windows both inside and outside the camera warn you by alternately displaying exposure information and a row of 000 's.

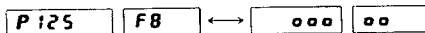

This alternate LCD indication tells you that both batteries should be replaced promptly to restore the camera to normal functioning.

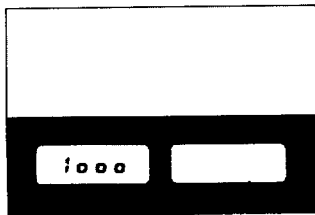
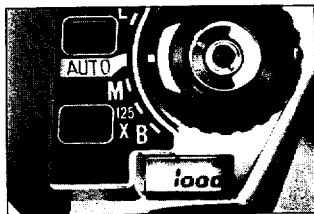

Using batteries correctly

- **Incorrect usage of batteries causes such hazards as leakage, heating or explosions. Polarity markings should be carefully checked while inserting batteries. If either battery is erroneously inserted, unexpected mishap may occur.**
- **The battery discharges small amounts of energy even when not in use. Therefore, the batteries supplied with your camera may be slightly below full capacity, as it has taken some time to reach you.**
- **Replace both batteries at the same time. Do not mix battery brands and types, or old batteries with new batteries.**
- **Battery life is approximately six months for alkaline and approximately one year for silver or lithium batteries.**
- **When not using the camera for long periods of time, you should remove batteries from the camera. Old batteries are apt to leak and damage the battery compartment. Always keep batteries out of the reach of children.**
- **Never break, recharge, or throw used batteries into fire as a precaution against explosions.**
- **Batteries should be kept warm in cold climates to prevent lowering of performance.**
- **Keep spare batteries on hand for convenience in photographing outdoors or while traveling, etc.**
- **When keeping the camera in a bag or case, lock the shutter release button to avoid the unnecessary consumption of battery power that may result from accidentally releasing the shutter.**

GRIP SUPER A

- To remove the grip, loosen the grip mount screw fully, and keeping the camera faced downward, slide the grip up until it comes off.
- To mount the grip, fit the grip mount socket (on the rear side of the grip) to the grip lug on the camera.
- Align the grip mount screw with the grip mount receptacle on the camera, and keeping the grip pushed down as indicated by the arrow, tighten the grip mount screw with a coin.

Note: The grip should be removed from the camera body when using the Motor Drive A or the Winder ME II.

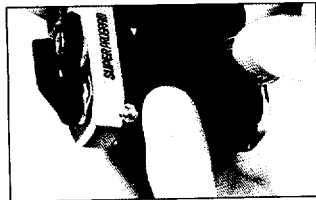
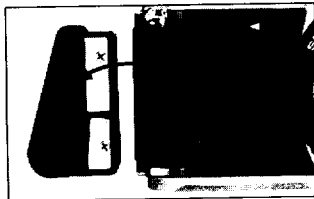

STRAP AND CASE

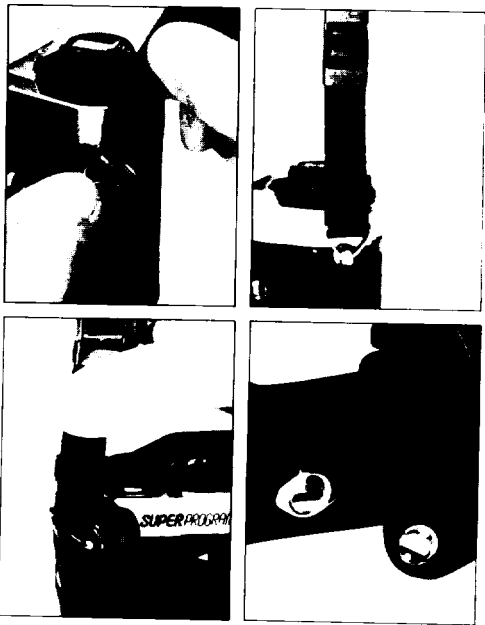

- First strip the clasp and belt ring from either end of the strap.
 - Let the strap end go through the neck strap ring and then the belt ring, and further through neck strap ring of the camera. The strap is then folded back.
 - Let the strap end run through the belt ring and then clasp as illustrated. Now the end is tightly caught by the clasp. The strap end may be passed through the inside or outside of the clasp.
-
- Insert the camera body into the back case and put both case hooks around the camera's strap eyelets. The camera body is now held securely in the case.
 - The standard soft case comes complete with a front cover.
 - To remove the front cover, turn the cover a full 180° while pulling it slightly towards you and the fastener of the cover unlocks.

LENS MOUNTING

To mount or interchange Pentax K, K_A and K_f mount lenses follow the steps below. (For screw mount lenses, see p. 57).

- Remove the body mount cap and the rear lens cap. If the finder cap is still on the eyepiece, remove it. (For the finder cap, see p. 53).
- Align the red dot on the camera body with the red dot on the lens (See A, B.). Seat the lens in the body mount and turn it clockwise until the lens locks with a click. When mounting the lens in dim light, method (C) is recommended. This method allows lens mounting by touch. Align the raised node on lens barrel with the lens release by touch. Then turn and lock as above.
- To remove the lens cap, press in on the notches at both sides.
- To remove the lens, press the lens release lever toward the camera body while turning the lens counter-clockwise.
- After removing a lens from the camera body, replace the front and rear lens caps to protect the lens from dust and stains.



Note: Don't damage or stain the electrical contact points on the mount face. When they become stained, wipe them with a clean, dry cloth.

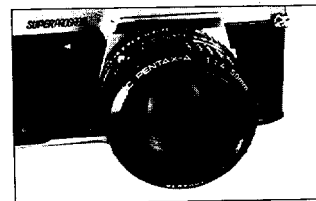
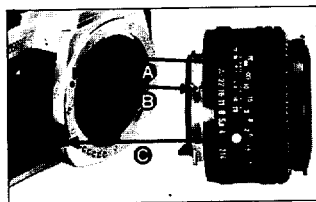

FILM WIND LEVER

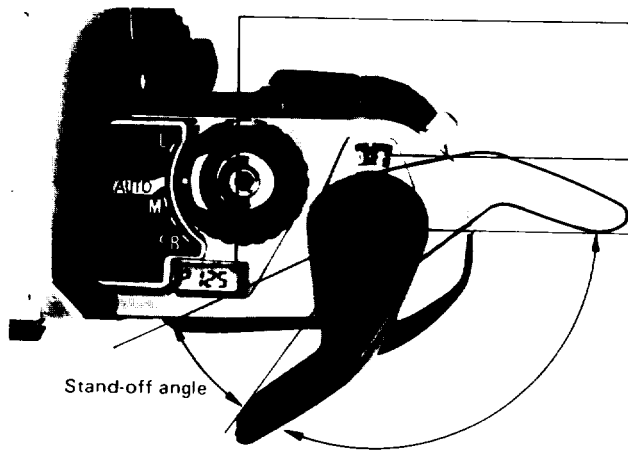

Film-advance/shutter-cocked indicator
When one frame is completely wound and the shutter is cocked for the next shot, the **■** mark appears on the shutter speed LCD.

Exposure counter
The scale is indexed as follows:
● - 0 - 2 - 4 34 - 36, with 0, 20, 34, 36 coded in red. The counter, which is interlocked with the film winding mechanism, indicates the number of exposed frames.

Stand-off angle

Setting the wind lever for rapid shooting

The film wind lever can be set at the stand-off position for faster film advance. Even if you remove your thumb from the lever, it remains at the stand-off angle, ready for the next quick shot. After completing a series of pictures, the lever should be pushed in to the original position.

Film advance stroke

The film wind lever should be thrown as far as it goes.

Note: The wind lever may stop in the middle of a stroke when the film comes to its end. Do not force the lever and rewind the film, leaving the lever as it is.

SHUTTER DIAL, SHUTTER RELEASE BUTTON AND RELEASE BUTTON LOCK

- The shutter dial is automatically locked at the AUTO or M position. To set the dial to other positions (L, 125X and B), turn the shutter dial while depressing the shutter dial lock release, and align the index mark (red line) on the dial to the desired position.

L = Shutter release button lock

AUTO = Automatic shutter speed control

M = Manual shutter speed selection

125X = 1/125 sec. for synchronization with electronic flash unit

B = Bulb shutter speed setting for time exposures

- By lightly depressing the shutter release button, you activate the exposure meter. Further pressure will release the shutter. The exposure meter automatically switches off approx. 30 seconds after you take your finger off the shutter release button.
- If you have finished shooting and the shutter is cocked, use the shutter release button lock to avoid accidental release. Set the shutter dial index to "L", and the shutter release will be locked with the exposure meter switched off.

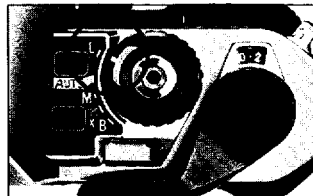
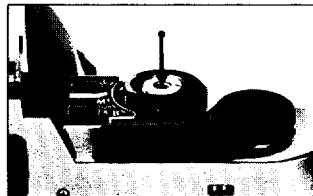
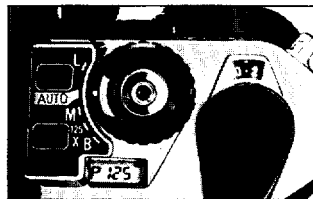



SETTING ASA/ISO FILM SPEED, MEMO HOLDER/GRIP

Set the film speed dial to the film speed indicated on your film package. Depress the film speed dial lock button, and set the desired ISO speed to the red index mark. Make sure that the dial is securely locked in position, by releasing the lock button and slightly rotating the dial to either side. The chart below represents the index markings on the film speed scale.

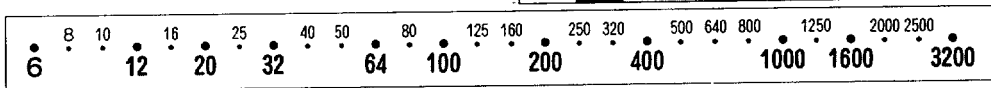
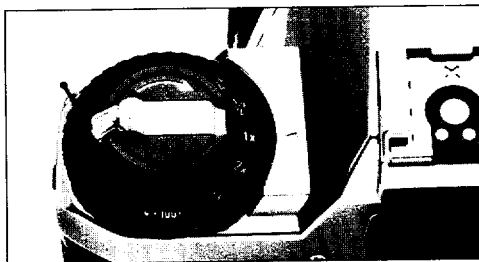

Memo Holder/Grip

As a reminder of the type of film in your camera, tear off the top of the film package and insert it in the memo holder frame on the grip at the right end of the back cover. The grip is shaped to give your thumb a firmer hold on the camera.

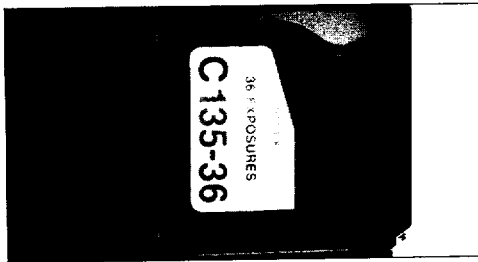

FILM LOADING

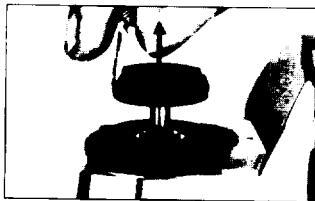

Load the camera with a 35mm film cartridge. Load or unload the film in the shade, avoiding direct sunlight. Set the shutter dial index (red line) to AUTO or M. This will automatically set the shutter speed to 1/1000 sec. so that you can advance film quickly until the counter registers "0".



- The camera back opens when you lift up sharply on the film rewind knob.
- Insert the film cartridge in the film chamber and lock the cartridge in place by returning the film rewind knob to its original position. If the knob does not fit tightly in to place, rotate the knob while lightly depressing it.
- Draw the film leader across the back and insert it between any of the white needles surrounding the film take-up spool. Insert the film in the direction shown in the illustration.

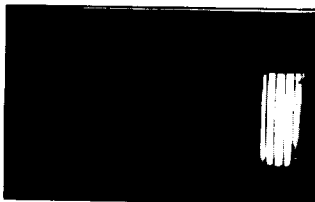

- Slightly wind the film by advancing the film wind lever to the position indicated in the photo, while making sure that both top and bottom sprockets engage the film perforations.

- Lightly rotate the film rewinding knob until any slack is taken up, and confirm that the film is properly fitted between both guide rails. Close the back cover tightly.

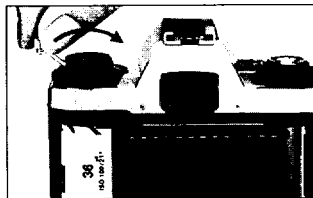

- Advance the film wind lever to check that the red vertical stripes of the film wind/rewind indicator flicker; this indicates that the film is advancing properly. Film advance can be also checked by the rotation of the rewinding knob.

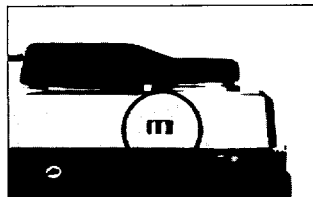

- Repeat shutter-tripping/film-advancing operation until the exposure counter reaches to "0". The next frame is ready for the first shot.

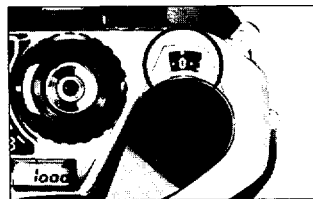

VIEWFINDER DISPLAYS

The split-image center spot and its surrounding microprism collar are brighter and easier to focus than the matte field although any of these can be used for focusing.

Visible at the bottom inside the viewfinder are two LCD displays for shutter speed and aperture value. In addition, viewfinder information includes auto/manual exposure data for each exposure mode, automatic flash data, exposure compensation warning, low battery warning, and error indication.

Shutter information LCD

P Programmed AE mode.

2000 | **15"**

Shutter speed in use. 2000 stands for 1/2000 sec. 15", stands for a full 15 sec. Shutter speeds are displayed in full stop increments.

B "Bulb" time exposure.

⚡ Means completion of flash recycling, and auto flash exposure confirmation with a dedicated flash unit.

E Error in shutter speed setting (flickering).
Combination of shutter speed and aperture is not appropriate.

Aperture information LCD

F 1.2 | **F 45**

Aperture value. An aperture range from f/1.2 through f/45 is indicated in 1/2 stop increments.

EF Exposure compensation warning (flickering). This warning indicates the exposure compensation dial is not set in the normal 1X position.

± Match numeral exposure adjustment indication in Metered Manual mode. -3 to +3 indicate exposure deviation from the proper value which is denoted by 0.

Low battery warning is indicated by alternate displays of shutter-speed/aperture combination, and the mark **000** | **00**.

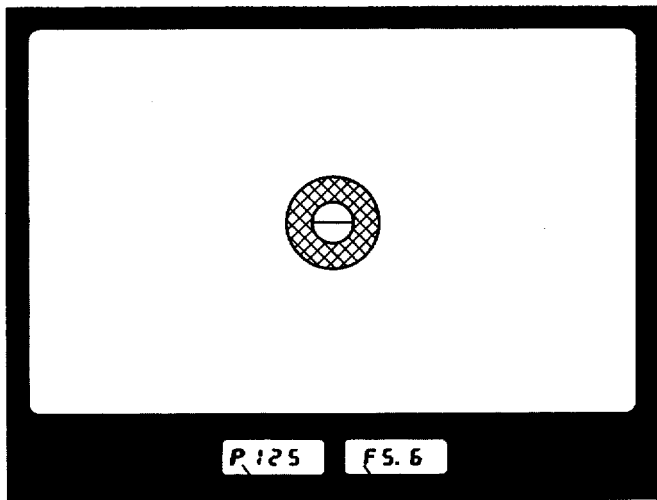

Aperture information LCD
Shutter information LCD

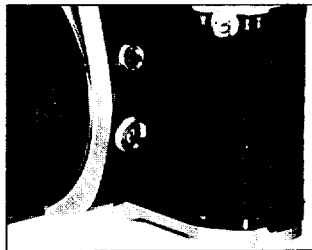

**Lighting button for
viewfinder LCDs.**

In dim light, the viewfinder LCDs may become hard to see. In that event, press the illumination button to throw more light on the finder LCDs.



P25o

F11

FOCUSING

You can focus in three ways, with the split-image, microprism, and/or matte field. To focus using the split-image, turn the focusing ring until the two images in the split-image circle at the center of the focusing screen are perfectly aligned. When using the microprism collar, focus until the glitter disappears from inside the collar. With the matte field, focus until the image on the matte field appears sharp and crisp.

Note: If the maximum aperture of the attached lens is smaller than $f/5.6$ (for example, $f/8$ as in the case of a long telephoto), it is easier to focus on the matte field since the split-image and microprism collar areas become much too dark for satisfactory focusing.

Diopter adjustment for viewfinder eyepiece

People who wear eyeglasses due to myopia, hypermetropia or presbyopia, sometimes find it difficult to focus while wearing their glasses. In this case, use the accessory diopter correction lenses M (See page 55).

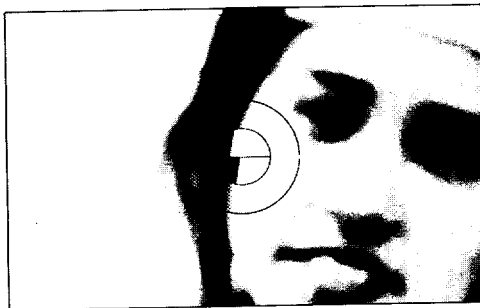

HOLDING THE CAMERA

Proper holding of the camera is essential to minimize camera shake which causes blurred pictures.

Practice holding and operating your Super Program before inserting your first film cartridge.

Generally there are three basic ways to hold the camera. In any case, hold the camera tightly to your face with your hands. Accessory Grip Super A and the memo holder/grip will help you keep a steady hold on your camera. Release the shutter gently while slowly breathing out. Strong pressure on

the shutter release button may cause blurred photographs. Take a secure, well-balanced posture without straining yourself. The portion marked ○ in the illustration should be drawn to your body. It is a good idea to stabilize your body and the camera using a tree, building wall, table, etc. For long exposures or while using telephoto lenses, it is recommended to use a tripod and a cable release in order to reduce camera shake to the minimum.

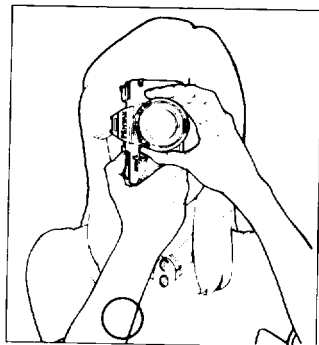
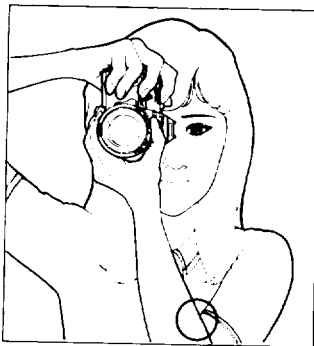
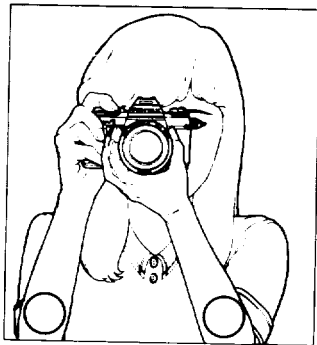

UNLOADING THE FILM

When the last frame of the film has been exposed, the film should be rewound into the cartridge before unloading from the camera. Do not force the wind lever beyond the number of frames indicated on the film cartridge.

To unload a cartridge

- Depress the film rewind button.
- Turn the rewind crank in the direction of the arrow to rewind the film.
- The red stripes in the film rewind indicator will flicker during rewinding, and they will cease flickering when rewinding is completed.
- After rewinding, lift up sharply on the film rewind knob to open the camera back and remove the film cartridge.

Note: Should you erroneously open the back before rewinding, do not leave it open. Close it immediately. The last few frames may be ruined by direct light exposure, but the majority of frames on the roll may still be unharmed. Whenever possible, it is also advisable to take the same pictures again with a new film.

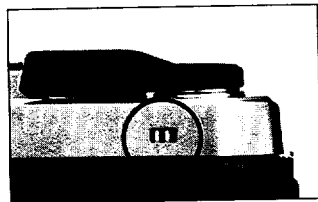
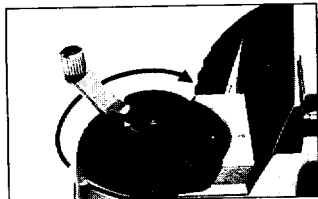
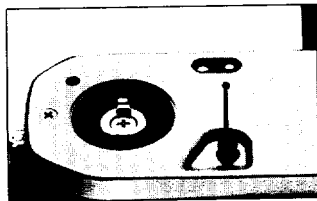

SIX EXPOSURE MODES

Pentax Super Program provides six different exposure modes. Choose the mode that suits the photographic situation and the subjects or feelings you want to express.

When using conventional Pentax K and Kf mount lenses on your Pentax Super Program, you can use the Aperture-priority AE, Metered Manual and all Auto Flash modes. When using new "A" series lenses, you can also select Shutter-priority AE and Programmed AE modes. The reason for this is that the last three modes are only available when the lens has an "A" or auto aperture setting.

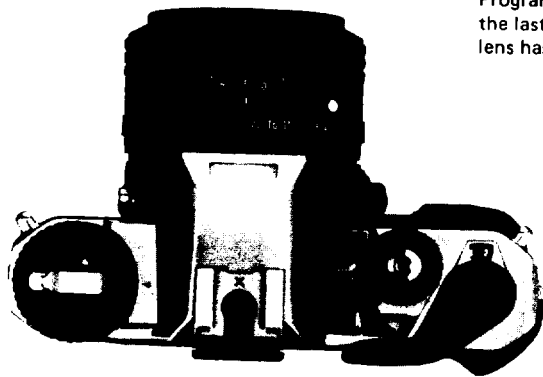

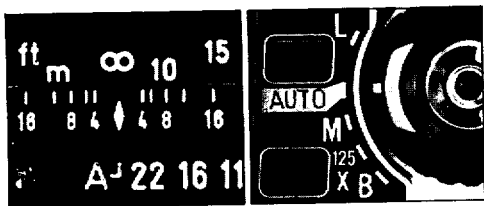

Programmed AE (lens on "A", shutter dial on "A")
 Your Super Program itself automatically selects the most appropriate combination of shutter speed and aperture to obtain proper exposure, changing them simultaneously according to the subject's brightness. The Programmed AE mode is most suitable for advanced photographers who want to shoot very quickly or for novices who do not want to be bothered by setting exposure controls according to light conditions. (Rf. 32 page for details)

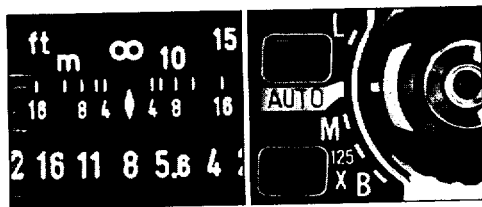

Aperture-priority AE (lens on any f-number, shutter dial on "A")
 When the aperture is set manually, the shutter speed is automatically adjusted by built-in electronic circuitry according to subject's brightness to provide appropriate exposure. When "depth-of-field" is important for your picture, this mode is recommended. It is suitable for both general photography and carefully controlled pictures such as portraits. (Rf. 34 page for details)

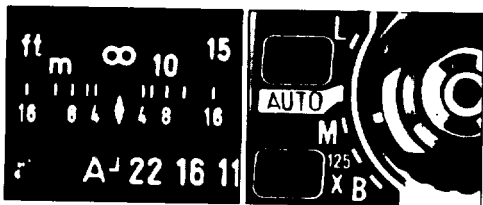

Shutter-priority AE

(lens on "A", shutter dial on "M")

The shutter-speed is set manually, and the aperture value is automatically controlled according to subject's brightness. Suitable for general photography, this mode is especially convenient for fast-moving situations, such as in sports photography. (Rf. 36 page for details)

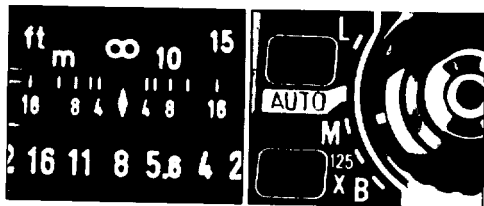

Metered Manual

(lens on any aperture, shutter dial on "M")

The combination of shutter speed and aperture is completely up to you. Guided by the meter indication in the viewfinder, you can adjust both controls to obtain proper exposure. If necessary, deliberate over- or under-exposure are also possible. (Rf. 38 page for details)

TTL Auto Flash

When connected with a Pentax dedicated TTL Auto Flash unit, the metering cell inside the mirror box of the Super Program will detect the light hitting the film plane, and automatically control flash output. If you use a TTL flash unit, and set the camera in the Aperture-priority AE mode, you can choose any aperture in the flash range, thereby achieving great control over depth-of-field in flash photos. (Rf. 42 page for details)

Programmed Auto Flash

If you use a Pentax dedicated TTL flash unit with the camera in the Programmed AE or Shutter-priority AE mode, the camera will automatically select the proper aperture and automatically control flash output. (Rf. 43 page for details)



PENTAX "A" LENS

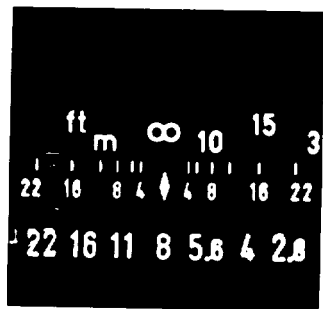
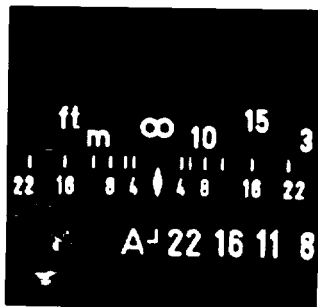

To set the lens in the A position, match the A-index (green line) on the aperture ring to the \blacklozenge index mark while depressing the aperture auto lock button. Release the button to lock the lens in the A position.

To release the lock, rotate the aperture ring towards aperture scale with the auto lock button depressed.

A (auto) setting Programmed AE mode
 Shutter-priority AE mode

The following modes are available when the lens is set in the manual f-stops:

f/number setting Aperture-priority AE mode
 Metered Manual mode

SHUTTER DIAL

The shutter dial is automatically locked when set at the AUTO or M position. To select other positions (L, 125X or B), rotate the shutter dial while depressing the shutter dial lock release, and match the index (red line) to the desired position. The following modes are available according to the position of the shutter dial.

AUTO	Programmed AE mode Aperture-priority AE mode
M	Shutter-priority AE mode Metered Manual mode
125X	Shutter-priority AE mode with the speed fixed at 1/125 sec.

Manual shutter speed select button

In the Shutter-priority AE or Metered Manual mode, select the desired shutter speed by depressing either of the two buttons next to the shutter dial. The digital figure on the shutter speed LCD indicator increases or decreases step by step as you press the buttons. The front button stops at 2000 (1/2000 sec.), and the rear button at 15" (15 secs.).

Precautions for shutter speed

If you shoot at shutter speeds slower than 1/60 sec. (30 – 15" on the LCD), you may occasionally get blurred pictures. If you couldn't use a faster shutter speed due to light conditions, the use of a tripod or flash unit is recommended. The use of film with higher sensitivity will also help avoid such low shutter speeds.

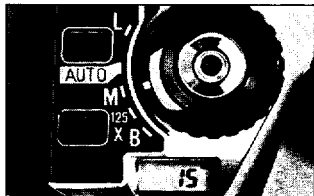
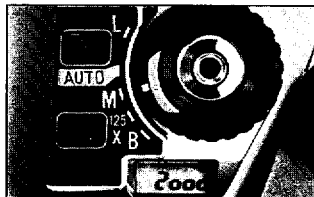
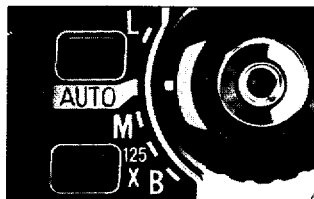

WARNING INDICATIONS IN EACH EXPOSURE MODE

- LCD displays on the camera top cover and inside the viewfinder flicker to warn of various errors or problems.
- The LCD displays in the table below show the examples. They vary depending on the lens in use, film speed (ASA/ISO), or the subject's brightness.
- The external shutter speed LCD provides the same figure as the shutter speed information LCD inside the viewfinder does.

External display	Viewfinder display		Meaning
	External LCD	Shutter speed information LCD	
P 1000	P 1000	F 2.2	These displays show exposure combinations beyond the meter coupling range in the Programmed AE mode. Correct exposure cannot be obtained.
P 2"	P 2"	F 1.4	
2000	2000		Overexposure. The camera is in the Aperture priority AE mode. It has chosen the fastest possible shutter speed for the aperture you have set. But the picture will still be overexposed unless you select a smaller aperture.
15"	15"		Underexposure. The camera is in the Aperture priority AE mode. It has chosen the slowest possible shutter speed for the aperture you have set. Try selecting a larger aperture. If the flexing stops, take your picture. If not, there is insufficient light for a normal exposure.
500	500	F 1.4	They indicate beyond the shutter/aperture coupling range in the Shutter priority AE mode. Appropriate exposure is obtainable by changing the shutter speed.
60	60	F 2.2	

2000	2000	F22	These show beyond the meter coupling range in the Shutter-priority AE mode. Correct exposure cannot be obtained.
2"	2"	F1.4	
125	125	+ 3	These warnings appear in the Metered Manual mode. +3 means you are three stops over normal exposure. -3 means three stops under. Adjust aperture or shutter speed until you see the ±0 sign.
125	125	- 3	
250	250	+ 3	Beyond meter coupling range in Metered Manual mode. It is not possible to get correct exposure by changing aperture or shutter speed. Use flash or a different sensitivity film.
8	8	- 3	
P 125	P 125	FB EF	The flickering letters EF in the viewfinder LCD remind you that the exposure compensation dial is set to a value other than normal - 1x.
E	E		If you set the shutter dial to "B" when the lens aperture ring is set at "A", LCD displays "E" to show an erroneous setting.
P 125 ↓ ↑ 000	P 125 ↓ ↑ 000	FB ↓ ↑ 00	Weak battery warning. In all exposure modes, when you see a row of 000 alternating with exposure information, it's time to change batteries.

- Refer also to the explanations concerning warnings in each exposure mode.
- As to the meter coupling range in the Programmed AE mode, refer to the diagram of Programmed AE control on Page 44. Meter coupling and shutter/aperture coupling ranges are explained on page 45.

SELECTING THE PROGRAMMED AE MODE

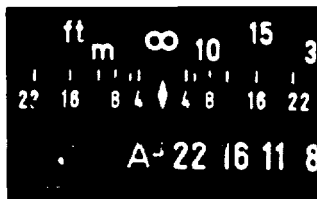

- Depress the auto lock button on the aperture ring of your Pentax "A" lens, and rotate its A-index (green line) to the index.

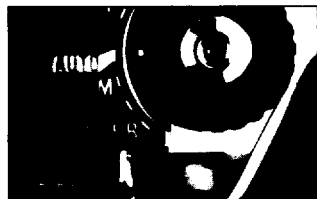

- Set the shutter dial index (red line) on top of the camera to the AUTO position. "P" (Programmed) will then be displayed on the LCD windows on the camera's top cover and inside the viewfinder.



- Lightly press the shutter release button, and a programmed combination of shutter speed and aperture value will be displayed on the LCD indicator in the viewfinder. At the same time, the same shutter speed will appear in the external LCD indicator. Further pressure on the button will release the shutter. When you take your finger off shutter release button, the meter switch automatically turns off after about 30 seconds as an energy-saving measure, and the displays of shutter speed and aperture value disappear. However, the "P" display remains on.

Programmed AE mode warnings

When the programmed combination of shutter speed and aperture value is beyond the meter coupling range, the camera displays two warnings.

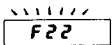
 P 1000  F 2.2 Both shutter speed and aperture flickering at high values. This indicates that the light situation exceeds the Super Program's light measuring ability since subject brightness is extremely high. To get a proper exposure, use another film with lower sensitivity or an ND filter.

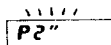
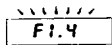
 P 2"  F 1.4 Both flickering at low values. The subject is extremely dark and below the lowest limit of the Programmed AE mode's meter coupling range. Use a higher speed film, flash or some other illumination source to throw more light to the subject.

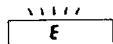
 E Should you happen to shift the shutter dial to "B" (Bulb), a flickering "E" (Error) warning appears on the shutter speed LCD. The shutter cannot be released even if the button is depressed. When you are using dedicated flash (TTL Auto, or Programmed Auto) in Programmed AE mode, the displays of shutter speed and aperture value are replaced by displays for flash photography when the flash is ready to fire.

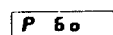
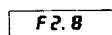
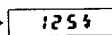
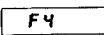
 P 60  F 2.8 →  125  F 4

SELECTING THE APERTURE-PRIORITY AE MODE

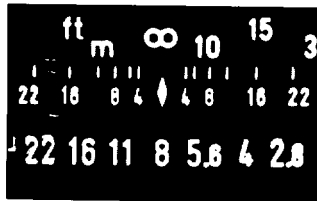

- Rotate the lens aperture ring to the desired f/stop. If the ring is locked at the "A" position, release it by depressing the aperture auto lock button.

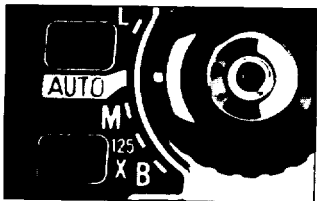

- Set the red index of the shutter dial to AUTO.

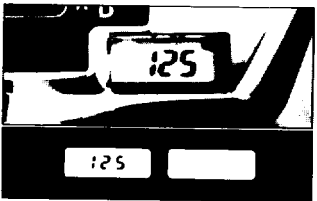

- Pressing the shutter release button slightly; the shutter speed will be digitally indicated both on the external LCD and the LCD inside the viewfinder. Further pressure will release the shutter. Shutter speed indication will disappear from both LCD indicators when the meter is automatically switched off by the built-in timer. Aperture-priority AE is the best mode for taking pictures with emphasis on depth-of-field. For more information, refer to page 48.

Aperture-priority AE mode warnings

If the subject is very bright, you will see a flickering



As remedy, shift the aperture ring towards smaller values (or, to the direction of $f/22$).

If the subject is dark you will see flickering.



Rotate the aperture ring towards the lens' maximum aperture ($f/1.4$). When the display stops flickering, you can take a proper exposure. If flickering continues even after the aperture is changed, the subject is too dark or too bright for a normal exposure. For very bright subjects, use a slower film or an ND filter, and dark subjects, use a faster film, flash or other artificial lighting.

SELECTING THE SHUTTER-PRIORITY AE MODE

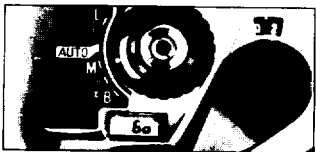
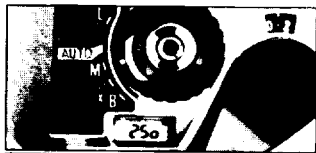
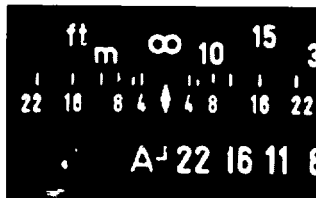

- Set the green line of the aperture A index to the \blacklozenge marking while depressing the lens aperture auto lock button.

- Set the red line of the shutter dial to the "M" (Manual) position. The shutter speed will be digitally displayed on the LCDs both outside the camera and inside the viewfinder.

- Select the shutter speed by pressing either of the manual shutter speed select buttons (next to the shutter dial). The front button makes the shutter speed faster; the rear button makes it slower. The shutter speed changes step by step with each time you press the button, and the speed changes continuously if you keep your finger on the button.

- When you press the shutter release button lightly, the aperture value is indicated on the viewfinder LCD. To take a picture, put a little more pressure on the button. The meter switch turns off about 30 seconds after you remove your finger from the shutter release button. The aperture indication then goes out, but the shutter speed display remains on.

- If you set the red line of the shutter dial to 125x, a variation of Shutter-priority AE is possible, but the speed remains fixed at 1/125 sec.

Shutter-priority AE mode Warnings

If the camera cannot automatically select an appropriate aperture for the shutter speed you have chosen, you will see the following warnings.

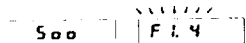

Maximum aperture flickering.

In this case, change to a slower shutter-speed (towards 15 secs.). Even at maximum aperture there is not enough light to shoot at the original shutter speed.



Minimum aperture flickering.

If this indication appears, change to a faster shutter-speed (towards 1/2000 sec.). Even at minimum aperture there is too much light to shoot at the original shutter speed. When the flickering stops, and you can start shooting.

If the subject brightness goes completely over the meter coupling range, both shutter-speed and aperture displays will flicker at high values:



If the subject is too dark for the meter, both displays will flicker at low values.



Should the subject be extremely bright, a lower sensitivity film or an ND filter will be effective. If the subject is too dark, the use of a higher speed film, flash or other supplemental lighting is recommended.

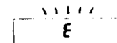

Flickering

Should you happen to shift the shutter dial to "B" (Bulb), a flickering "E" (Error) appears on LCDs both outside the camera and inside the viewfinder to warn against erroneous operation. The shutter cannot be released even if the button is depressed.

SELECTING THE METERED MANUAL MODE

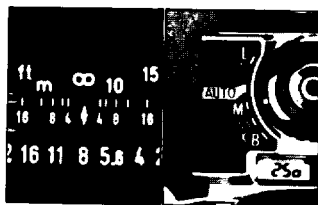
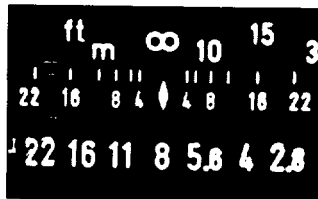
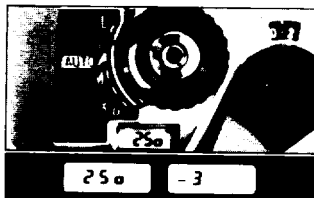

- Set the shutter dial red-line index to "M" (manual) and select the desired shutter speed. The shutter speed will be displayed on LCDs both outside the camera and inside the viewfinder.
- Rotate lens aperture ring to an F value. Should the lens be locked at A (auto), release it by depressing the aperture auto lock button.
- Slightly depress the shutter release button, and you will see one of the following indications (+3, +2, +1, ±0, -1, -2, or -3) displayed on the aperture value window in the viewfinder. These figures show the steps of over- or under-exposure (EV value).
 - + = over-exposure
 - ±0 = correct exposure
 - = under-exposure

Should the lighting condition go over the limit of three steps, the +3 or -3 indication flickers.

- For normal shooting, adjust the lens aperture so that correct exposure, indicated by ±0, is obtained. Should you select the lens aperture prior to the shutter speed, adjust the shutter speed to obtain the correct exposure. If you prefer over- or under-exposure, you can freely select any exposure applying the indication as a guidance. As soon as the meter switch is turned off by the built-in timer, the aperture indication goes out, but the shutter speed display remains on.

Warnings for Metered Manual mode

The following indications will be given for over- or under-exposure.

| 125 | | + 3 | Aperture LCD Flickering

This indicates over-exposure of more than three steps. Change to a faster shutter speed (towards 1/2000 sec.), or select a smaller aperture by rotating the aperture ring toward f/22.

| 125 | | - 3 | Aperture LCD Flickering

In this case, the exposure is more than three steps under. Change to a slower shutter speed (towards 15 secs.), or rotate the aperture ring towards f/1.4. When your shutter/aperture combination comes within the range of 13, the flickering stops.

If the situation is beyond the meter coupling range, indications are as follows.

| 250 | | + 3 | Both flickering at high values. The subject is too bright.

| 8 | | - 3 | Both flickering at low values. The subject is too dark.

In either case, the subject is not within the Pentax Super Program's meter coupling range. So you will not be able to obtain a proper exposure simply by changing aperture and shutter speed settings.

USING PENTAX DEDICATED AUTO FLASH UNITS

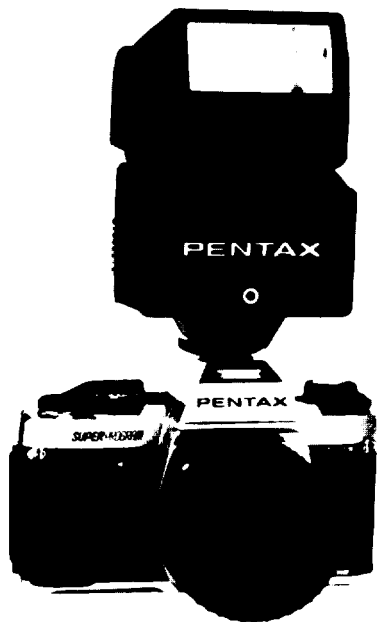

The combination of your Pentax Super Program and any Pentax dedicated auto flash unit allows a variety of convenient functions as outlined in the following page.

If your flash unit requires the use of a synch cord, connect the cord to the X-synch socket found on your Pentax Super Program.

Operations/functions of each electronic flash unit are fully explained in their respective operating manuals.

Note: When you use the Super Program with AF400T, connect the flash unit with 4P Sync Cord B to the camera hotshoe.

*TTL Auto Flash units.

Flash functions of Pentax Super Program with:	*AF400T	*AF280T	*AF200T	*AF080C	AF200S	AF160
Flash recycling displayed in Viewfinder by $\frac{1}{2}$ mark.	○	○	○	○	○	○
When camera is set at AUTO, shutter speed automatically switches to X-synch speed (1/125 sec) for flash photography.	○	○	○	○	○	○
Correct auto flash exposure is confirmed by lighting or flickering of $\frac{1}{2}$ mark immediately after the flash emission.	○	○	○	○		
Film-plane-metering for auto flash is available (TTL Auto Flash).	○	○	○	○		
In manual mode, flash photography is possible with shutter speeds slower than 1/125 sec.	○	○	○	○	○	○
Proper aperture is automatically set in Programmed AE mode and/or Shutter-priority AE mode.	○	○	○	○		

Note: When any of the above flash units other than the AF-160 is used with the Super Program with the flash mode set at AUTO, the flash may not fire if the subject is too bright for flash photography.

SELECTING THE TTL AUTO FLASH MODE

When you set the camera to the Aperture-priority AE or the Metered Manual mode;

- You can set any desired f-number on the lens aperture ring for the TTL Auto Flash control.
- The LCDs indicate the automatically set synchronization shutter speed of 1/125 sec. as the TTL Auto Flash recycles. (Rf. page 43 for the slow speed synchronization in the Metered Manual mode.)

When you choose the Programmed AE or the Shutter-priority AE mode;

- The lens aperture is automatically set to f/4 (in the case of the AF080C, f/8) and the LCDs indicate the automatically set synchronization shutter speed of 1/125 sec. For instance, the camera is set to the Programmed AE mode and the ISO is set at 100, the LCD indications automatically change as follows.

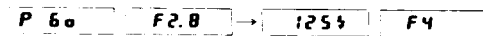

- When you use other films than ASA/ISO 100, the aperture will change according to the film speed registered on the camera.

Note

If you leave the power switch of the Pentax dedicated auto flash on in any mode, the camera's exposure control circuitry will also be automatically switched on. And it will remain on, consuming the camera's battery power. So remember to turn off the flash power switch. If you use a Pentax dedicated flash unit in the M or MS mode, the flash's automatic coupling system will not function with the camera set in Programmed AE or Shutter-priority AE mode.

SELECTING THE PROGRAMMED AUTO FLASH MODE

When you set the camera to the Programmed AE or the Shutter-priority AE mode;

- Choose an Auto position on the flash mode selector (red, green, yellow) of the dedicated TTL Auto Flash unit.
- As the TTL Auto Flash unit recycles, the shutter speed will be automatically changed to the synchronization speed of 1/125 sec. and the lens aperture is also automatically set to the predetermined value shown in the table below according to the Auto position (red, green, yellow) you choose.

(With ISO 100 film)

	AF200T	AF280T	AF400T
"Red" mode	f/2.8	f/4	f/4
"Green" mode	f/5.6	f/8	f/8
"Yellow" mode	—	—	f/11

For instance, if you set the flash mode selector to the red position of the AF200T, at ISO 100, the LCD indication shall be as follows.



When you use other films than ISO 100, the aperture will change according to the film speed registered on the camera.

When you set the camera to the Aperture-priority AE or the Metered Manual mode;

- Select an Auto position on the flash mode selector (red, green, yellow) of the dedicated auto flash unit.
- Set the lens aperture to the designated value on the flash unit's calculator board.
- As the dedicated auto flash unit recycles the shutter speed is automatically changed to the synchronization speed of 1/125 sec.

Reminders for both TTL and Programmed Auto Flash modes:

- In Metered Manual mode, speeds between 1/2000 and 1/250 sec. automatically change to synch. speed, while slower than 1/125 sec. speeds stay as are when the dedicated flash recycles. Choosing any slow speed, you can enjoy existing light photography with flash fill-in.
- In each automatic flash mode, the correct exposure is confirmed in the viewfinder. When the correct exposure is obtained with the dedicated flash in Auto modes, this confirmation mark ζ appears. If the auto flash confirmation mark ζ appears or flickers on the viewfinder LCD immediately after light emission, the subject has received proper flash lighting.

The Super Program's shutter-speed and aperture combination in the Programmed AE mode is shown in the chart.

The red line represents the variation of shutter-speed and aperture combination with an $f/1.4$ lens. Note that only the shutter-speed slows down after the lens aperture reaches its limit of $f/1.4$ in combination with a speed of approx. $1/30$ sec. When you use a lens with a different maximum aperture, the exposure program varies the aperture and the shutter-speed in combination until reaching the maximum aperture of your lens. For example, with an $f/2.8$ lens the program varies the combination as shown by the red dotted line. Note that only the shutter-speed changes after the maximum aperture is reached. The fine red line in the Programmed AE diagram indicates the Automatic Exposure control range for a lens with minimum aperture smaller than $f/22$, or for a film with ISO speed other than 100. The fine red-dotted line indicates the range for a lens with maximum aperture smaller than $f/1.4$, or for a film with ISO speed other than 100.

Meter coupling range and Shutter/Aperture coupling range

The meter coupling range means the range of subject luminance within which the built-in exposure-meter works to control exposure. The shutter/aperture coupling range is that part of the meter coupling range within which shutter-speed and aperture value can be combined for proper exposure control. When you use a 50mm $f/1.4$ normal lens and an ISO 100 film, the meter coupling range is from EV 1 ($f/1.4$ -1 sec. or $f/2$ -2 sec.) to EV 19 ($f/22$ - $1/1000$ sec. or $f/16$ - $1/2000$ sec.). The range varies according to film speed (ISO). The variation of the meter coupling range is shown by slanting lines which shift with ISO ratings. The frame in the center shows the meter and shutter/aperture control coupling range.

EV (Exposure Value)

EV represents a combination of the shutter-speed and the lens aperture which is determined by the film speed (ISO) and the brightness of the subject.

EXPOSURE COMPENSATION

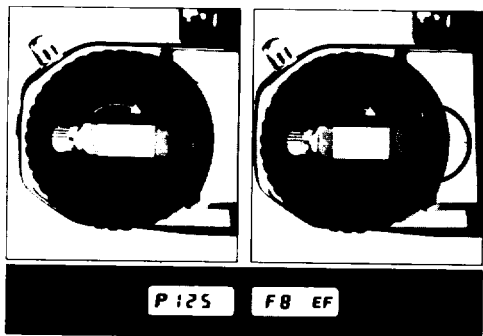

Exposure compensation range

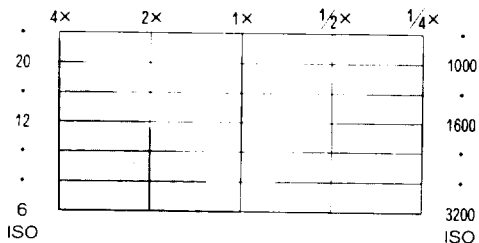

The automatic exposure system of your Super Program tends to underexpose backlit subjects and overexpose spotlighted subjects on a stage, etc. In such cases, you can compensate by setting the exposure compensation dial. When shooting a subject against a bright background (backlit subjects), increase the exposure by setting the dial either to 2X or 4X. When your subject is spotlighted against a dark background, decrease the exposure by setting the dial to 1/2X or 1/4X. To set the dial, turn the knurled ring. Use of the exposure compensation dial changes the shutter speed in Aperture-priority AE mode, the aperture in Shutter-priority AE mode, the programmed value in Programmed AE mode, and the \pm values to which you adjust the exposure, in manual mode.

Exposure compensation dial and Film speed scale

At both extremes of the film speed scale, the use of the exposure compensation dial is limited as shown in the chart. When the exposure compensation dial is employed, the "EF" (exposure factor) indication will flicker on the aperture LCD in the viewfinder. Always return the exposure compensation dial to 1X when compensation is no longer required.

1X



2X



1X

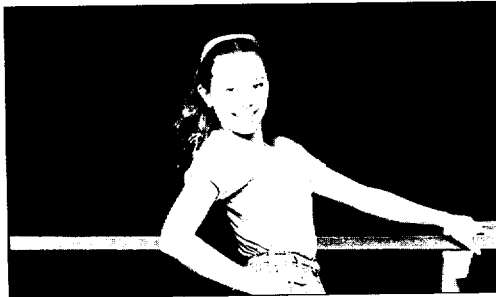

1/2X



DEPTH-OF-FIELD

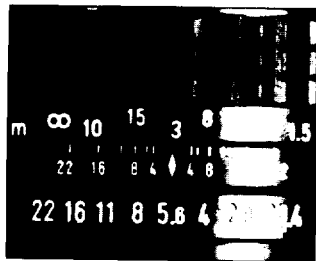
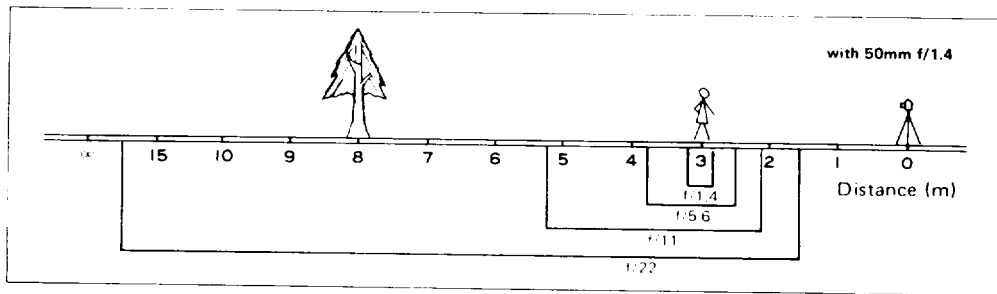

Depth-of-field is the range between the nearest and farthest distances which are in focus at a given lens aperture.

The minimum aperture (for example f/22) gives you the greatest depth-of-field, or area in focus. The maximum aperture (for example f/1.4) gives you the smallest depth-of-field. When you vary aperture value, the range "in focus" changes accordingly, so that you can create different photographic effects in your pictures. As illustrated in the pictures on the right (examples of f/1.4 and f/22), the distance range in focus can be confirmed by the depth-of-field scale on the lens.



f/1.4 (2.85 ~ 3.16)



f/22 (1.67 ~ 16.88)

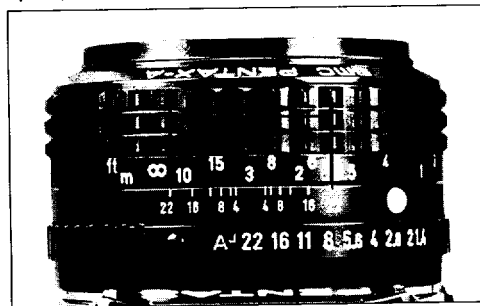
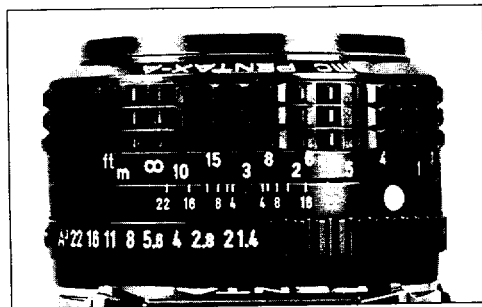



Depth-of-field preview

Your Super Program is equipped to help you preview just what will and what will not be sharp in your pictures. By depressing the preview lever near the lens mount, you can close the lens down to whatever aperture you have set. You can then preview how much sharpness you will get in your picture by examining the picture area on the ground glass. After previewing your picture, if you release the preview lever, the lens will return to full aperture for focusing. You cannot, however, preview the depth of field with your Super Program set in the Programmed AE and Shutter-priority AE modes. **Note:** Taking pictures with the preview lever depressed will result in incorrectly exposed pictures.

Depth-of-field Table: SMC Pentax-A 50mm Lens

Distance scale	1/1.4	1/2	1/2.8	1/4	1/5.6	1/8	1/11	1/16	1/22	unit: meter
0.45m	0.448 0.453	0.446 0.454	0.445 0.455	0.443 0.457	0.440 0.460	0.436 0.465	0.431 0.471	0.423 0.481	0.414 0.493	
0.5m	0.497 0.503	0.495 0.505	0.494 0.507	0.491 0.509	0.487 0.513	0.482 0.519	0.476 0.527	0.466 0.540	0.454 0.557	
0.6m	0.595 0.605	0.593 0.607	0.590 0.610	0.586 0.615	0.581 0.621	0.573 0.630	0.564 0.642	0.549 0.663	0.532 0.691	
0.8m	0.791 0.810	0.787 0.814	0.781 0.820	0.774 0.828	0.764 0.840	0.749 0.859	0.732 0.883	0.705 0.927	0.675 0.987	
1.0m	0.985 1.016	0.978 1.023	0.970 1.032	0.958 1.046	0.942 1.066	0.919 1.098	0.892 1.140	0.851 1.218	0.806 1.328	
1.5m	1.464 1.538	1.449 1.555	1.430 1.578	1.402 1.613	1.366 1.664	1.316 1.746	1.259 1.861	1.174 2.093	1.086 2.462	
2.0m	1.935 2.070	1.908 2.101	1.874 2.144	1.825 2.213	1.764 2.312	1.679 2.478	1.584 2.724	1.449 3.265	1.314 4.298	
3.0m	2.853 3.164	2.794 3.239	2.719 3.346	2.615 3.521	2.487 3.785	2.318 4.265	2.137 5.073	1.892 7.426	1.665 16.883	
10.0m	8.488 12.171	7.973 13.421	7.375 15.552	6.631 20.422	5.846 35.101	4.966 72.265	4.181 108.883	3.313 166.883	2.655 266.883	
∞	55.370	38.772	27.707	19.408	13.876	9.726	7.086	4.885	3.565	



TRIPOD, B(BULB) AND TIME EXPOSURES



Tripod

In order to prevent large diameter lenses from interfering with proper mounting of the camera on a tripod, insert the accessory spacer ring. To prevent movement of the camera during long exposures, use a tripod and cable release.

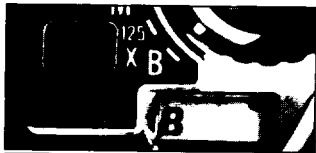

Bulb (B)

Bulb is used to make long exposures of more than 15 seconds. Set the shutter dial index (red line) to the "B" position, and the shutter will remain open as long as the shutter release button is depressed. The shutter speed LCD inside the viewfinder indicates "B". Bulb cannot be used when the aperture ring of an A lens is set at A (Auto). Should the "B" be set on the shutter dial, the "E" (error) indication flickers as a warning on the shutter speed LCD.

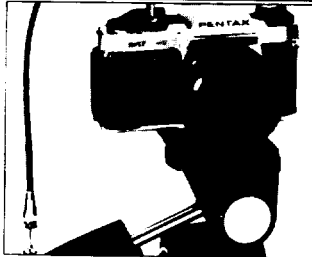

Time Exposures

For time exposures use Pentax Cable Release Type 30 or 50 with the shutter dial set at "B."

SELF-TIMER

The self-timer is used when you want to include yourself in the picture with your family, friends, etc. After cocking the film wind lever, draw the self-timer lever in the direction of the arrow, and depress the shutter release button. The timer delays shutter release for about 12 seconds. Self-timer operation is indicated by red light and electronic beeping. 2 seconds before a shutter release, the frequency of flickering and beeping increases. The self-timer can be cancelled even after pressing the shutter, by returning the lever to its original position.

The self-timer cannot be used with the shutter set at "B". "E" flickers on LCDs both outside the camera and inside the viewfinder to warn you of an erroneous setting. When using the self-timer, cover the viewfinder eyepiece with the accessory finder cap; otherwise, light entering from the rear of the camera may make the shutter speed faster, adversely affecting the exposure.

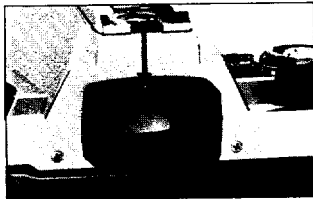

USE OF NON-DEDICATED FLASH UNITS

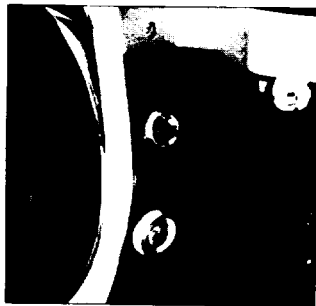
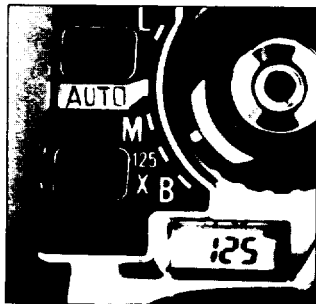

- In using an ordinary flash unit, adjust the shutter dial index (red line) to 125X. The shutter speed will be indicated as 125, but there will be no LCD indication of f/stop.
- Set the lens aperture according to the camera-to-subject distance (Refer to the instructions accompanying the flash unit).
- When using a synch-cord, connect it to X-synch socket on your Super Program.

Note: Flash units available from other makers with dedicated flash coupling capability, special purpose flash units, etc., will tend to cause malfunctions or damage to the electronic systems of your Super Program.

DIOPTER ADJUSTMENT, CHANGING BACK COVER

Correction lenses M are available for the Super Program viewfinder. There are 8 auxiliary M lenses: -5, -4, -3, -2, -1, +1, +2 and +3D. Choose the one that suits your eye, and put it in the eyepiece accessory slots as illustrated. Before buying one, try it for yourself with the lens actually attached to your camera.

Changing the back cover

The back cover must be removed from your Pentax Super Program to use such accessories as the Dial Date ME or Digital Data M data-imprinting devices. Open the back cover, and pull it slight-by while pushing down the back cover release pin to disengage the locking mechanism. Then the cover can be easily removed. When reattaching it, first put the lower back-cover-release lug into position, then match the upper lug with the release pin pushed downward. Release the pin to attach the back to camera body.

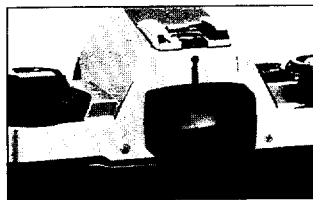

INFRARED INDEX MARK

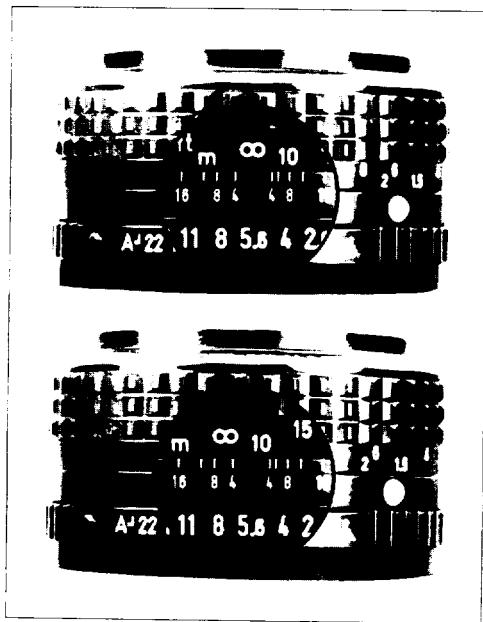

If you intend to take infrared photographs using infrared film and R2 or O2 filters, it is necessary to compensate for the difference between visible light focus and infrared focus. As shown on the left, note the subject-to-camera distance on the lens distance scale as you focus through the viewfinder and turn the focusing ring until that distance setting aligns with the red infrared index mark. The figure shows an example in which the subject-to-camera distance is set at infinity (∞).

As for exposure control required in infrared photography, refer to the instructions contained in the film package.

USING SCREW-MOUNT TAKUMAR LENSES

Conventional screw-mount lenses can be easily attached to the lens mount of your Pentax Super Program by using the optional Mount Adaptor K. But there are some limitations.

- Put the Mount Adaptor K in the body mount by matching both marks.
 - To lock it, rotate the adaptor clockwise (65°) with a pointed object such as a ball-point pen.
- Now your Super Program can accept any conventional Pentax screw-mount lenses.
- To remove the adaptor, press the spring pin on the adaptor with some pointed aid and rotate it counterclockwise until it stops.

Limitations in using screw-mount lenses on the Super Program

- The distance scale of the lens is usable as it is, up to infinity (∞).
- Automatic diaphragm coupling doesn't function due to the difference in coupling system.
- The exposure is metered with aperture stopped down.
- Programmed AE and Shutter-priority AE modes cannot be used with screw-mount lenses.
- There is not automatic aperture setting even with dedicated flash units.

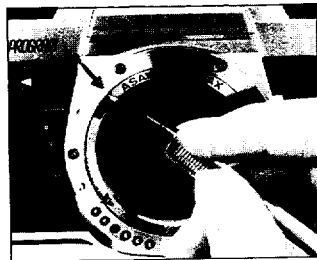
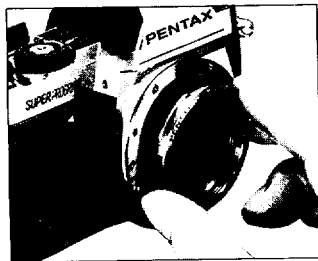

HOW TO USE VARIOUS ACCESSORIES WITH YOUR SUPER PROGRAM

- When you attach the following accessories to the Super Program, use the stop-down (or working aperture) metering mode or Metered Manual mode:
Bellows Unit III

Microscope Adaptor K
Helicoid Extension Tube K
Extension Tube K Set
Reverse Adaptor K 49mm/52mm
6 x 7 Lens Mount Adaptor K
Telescope Adaptor K

- When you attach the following accessories to the Super Program, use the Aperture-priority AE mode or Metered Manual exposure mode:

Auto Bellows A Set and M Set new
Auto Extension Tube K Set
Auto Extension Tube K 100mm/50mm
Rear Converter K T6-2X

Note: The scale and double cable release of the Auto Bellows M Set new cannot be used with the Super Program.

- Use the Refconverter A because with the Refconverter M the viewfinder LCD of the Super Program is not visible.
- When using the Winder ME II with the Super Program, be sure to set the AUTO/125X indicator of the winder at AUTO. If set at 125X, it may cause malfunction.
- Do not use the older model Winder ME: it will not operate properly with the Super Program.
- The Super Program's Programmed AE and Shutter-priority AE modes do not function with a Pentax dedicated flash set at "M" (manual) or "MS" (manual synchronization).
- As you set up for multi-flash photography with dedicated flash units, use your Pentax Super Program in the Aperture-priority AE or the Metered Manual mode.

Q&As ON YOUR PENTAX SUPER PROGRAM

● **With the shutter dial set to "AUTO" the viewfinder LCD fails to indicate anything.** Did you slightly depress the shutter release button? Are batteries properly inserted in your camera? (See details on page 6)

● **What happens if the batteries are completely depleted?**

LCDs outside the camera and inside the viewfinder are blank. Even if the shutter is pressed, the shutter cannot be released. Replace the batteries with new ones. (See page 7.)

● **What is ISO 100?**

It shows the sensitivity of the film in use. You cannot obtain proper exposures unless you set the camera to the proper film speed. (See page 15)

● **Why are my pictures out of focus?**

Always be sure to focus accurately by using the split image and/or microprism on the finder screen. Camera shake often causes blurred pictures. Use shutter-speeds faster than 1/60 sec., and hold your camera tightly while shooting. (See pages 19 and 20)

● **Only the "1000" indication appears on the shutter speed LCD in spite of the fact that the exposure mode is properly set.**

Repeat film advancing operation until the film counter registers "1". (See page 7)

CAMERA MAINTENANCE

CLEANING:

- Always keep the viewfinder eyepiece, lens and filters as clean as possible. To remove loose dust and dirt, first use the blower and then the brush. Do not try to wipe off granular dirt or dust — it's an excellent way of scratching the glass.
- Smudges, such as fingerprints, should be carefully wiped away with either lens tissue or a clean, soft cloth. Clean, plain cotton handkerchiefs that have already been washed a few times are particularly good for this. Breathing on the lens before wiping is effective; but be sure to wipe away all moisture completely. Commercial lens cleaners are also effective.
- Never touch the mirror or the shutter leaves. Minor dirt or spots on the mirror will not affect the clarity of your pictures.
- Take care not to drop the camera or knock it against anything solid. Accidents or rough handling can easily damage the internal mechanism, even though externally nothing seems to have been damaged.

KEEP YOUR CAMERA DRY:

- Your camera is *not* waterproof. There are several places where water can get inside and do a great deal of damage. Take care to protect both body and lens from rain or splashing water. If your camera should get wet, dry it off immediately with a clean, soft cloth.
- If your camera becomes completely soaked, it may malfunction. In this instance, bring it as soon as possible to an authorized Pentax service center.

STORAGE:

- Where to keep your camera while you are not using it is an important point. The best storage place is cool, dry, clean and well-ventilated. Because of the possible build up of humidity, it is risky to store your camera in a cabinet or closet. It's also a good idea to keep your camera in its bag or case while you are not using it.

RESISTANCE TO TEMPERATURE EXTREMES AND CHANGES

The temperature range at which your camera will continue to function properly stretches from 50°C to -20°C. However, resistance to cold could be hampered by dirty oil. Therefore, if the camera is to operate at full efficiency in very cold conditions, it must be overhauled and all oil must be replaced. Sudden changes in temperature will often cause moisture to condense inside or outside your camera. This is a possible source of rust, which may be extremely harmful to the mechanism. Furthermore, if the camera is taken from a warm temperature to a sub-freezing one, further damage may result from the formation of icelets. Thus, sudden temperature changes should be avoided as much as possible. As a guide, a temperature change of 10°C should be allowed to take place gradually over a period of at least 30 minutes. If this is not possible, keeping the camera in its case or bag will help somewhat in minimizing the effects of a rapid temperature change.

Extremely low temperature reduces the efficiency of the battery. Therefore, the camera should be protected against low temperature. Put the batteries into the camera right before shooting. For extremely low temperature, use new batteries.

A few notes on the LCD (Liquid Crystal Display):
In high temperature, approximately 60°C or 140°F or above, the LCD windows may turn black. In low temperature, the response-time of the display may slow down considerably. These phenomena do not indicate either camera break-down or break-down of the LCDs themselves. They are characteristic of LCDs, and the LCDs will return to normal when the temperature becomes normal.

SPECIFICATIONS

- Type:** 35mm SLR camera with multi-mode automatic exposure controls, electronically-controlled focal plane shutter, and open-aperture center-weighted Through-The-Lens metering.
- Six Exposure Control Modes:** Programmed AE, Aperture-priority AE, Shutter-priority AE, Metered Manual, TTL Auto Flash, and Programmed Auto Flash mode.
- Exposure Control Mode Setting:** By using combinations of settings on shutter dial and aperture ring of "A" series lenses.
- Film:** 35mm film.
- Format:** 24 x 36 mm
- Lens Mount:** Pentax K_A Bayonet (A Pentax K bayonet mount with electrical contact).
- Shutter:** Seiko MFC-E3 vertical-run metal focal-plane shutter, automatic exposure and manual settings electronically-controlled speeds from 15 to 1/2000 sec., 1/125 sec., and B. Electro-magnetic shutter release with release button lock.
- Exposure Indication in Viewfinder:** Liquid Cristal Display (LCD) Automatic and manual shutter speeds, automatically set lens apertures, exposure factor warning, shutter-speed setting error warning, battery life warning, and Programmed AE indication (P). LCD window illumination.
- External Indication:** Automatic and manual shutter speeds, Programmed AE indication (P) and shutter cocked indicator.
- Flash Synchronization:** Hot shoe (X-Synch contact, dedicated flash contacts), X-synch at 1/125 sec.
- Dedicated Automatic Flash Coupling:** Automatic setting of 1/125 sec. synch speed with dedicated automatic flash units. TTL-automatic flash control provides film-plane metering. Slower than 1/125 sec. synch flash photography is possible at Manual mode setting.
- Self-Timer:** Electronically controlled, delay time indication by flashing lamp and electronic buzzer, approx. 12 sec. delay time, possible to cancel at any time; initiate process by pressing shutter release button.
- Viewfinder:** Silver-coated pentaprism finder with split-image/micropism focusing screen; shows 92% of the picture area, 0.82X magnification with 50mm lens at infinity; -1.1 Diopter eyepiece.

Mirror: Back-swing type instant-return mirror.

Film loading: Magic-needle loading.

Film Transport: Single-stroke, rapid wind lever with 135° throw and 30° standoff angle; LCD shutter cocked indicator; film advance and rewind indicator window. Accepts Winder ME II, Motor Drive A.

Exposure Counter: Additive type, automatic resetting. Automatically sets shutter-speed at 1/1000 sec. up to '0' frame on the counter when shutter dial is set at AUTO or M.

Film Rewind: Crank type.

Exposure Metering: Open aperture, Through-The-Lens, center weighted, average area metering system with GPD cell. Film-plane Metering for dedicated automatic electronic flashes.

Metering Range: EV 1 (f/1.4 1 sec.) – EV 19 (f/16, 1/2000 sec. or f/22, 1/1000 sec.) with 50mm f/1.4 lens and ISO 100 film.

ISO Range: 6 – 3200.

Exposure Compensation Exposure: Compensation dial indexed at 4X, 2X, 1X, 1/2X and 1/4X.

Depth-of-Field Preview: Via depth-of-field preview lever when aperture set manually.

Power Source: Two 1.5V alkaline or silver-oxide batteries, or one 3V lithium battery.

Metering Circuit Main Switch: Switched on by shutter release button and remains on for about 30 sec., shut-off by built-in timer.

Battery Warning: When batteries grow weak, LCD alternately flashes exposure designations and 'ooo' sign. When batteries exhausted, LCDs go blank and shutter locks.

Back Cover: Standard camera back with spring catch, built-in memo holder/grip, fully interchangeable with Dial Data ME and Digital Data M.

Size & Weight: 131mm x 86.5mm x 47.5mm, 490g (body only, without batteries)
131mm x 86.5mm x 84.5mm, 725g (with f/1.4 lens, without batteries)

WARRANTY POLICY

All Pentax cameras purchased through authorized bona fide photographic distribution channels are guaranteed against defects of material or workmanship for a period of twelve months from date of purchase. Service will be rendered and defective parts will be replaced without cost to you within that period, provided the equipment has not been abused, altered, or operated contrary to instruction. Because the tolerances, quality, and design compatibility of lenses other than Pentax lenses are beyond our control, damage caused by use of such lenses will not be covered by this warranty policy. The manufacturer or its authorized representatives shall not be liable for any repair or alterations except those made with its written consent and shall not be liable for damages from delay or loss of use or from other indirect or consequential damages of any kind, whether caused by defective material or workmanship or otherwise; and it is expressly agreed that the liability of the manufacturer or its representatives under all guarantees or warranties, whether expressed or implied, is strictly limited to the replacement of parts as hereinbefore provided.

Procedure During 12-month Warranty Period

Any Pentax which proves defective during the 12-month warranty period should be returned to the dealer from whom you purchased the equipment or to the manufacturer. If there is no representative of the manufacturer in your country, send the equipment to the manufacturer, with postage prepaid. In this case, it will take a considerable length of time before the equipment can be returned to you owing to the complicated customs procedures required in Japan in importing and re-exporting photographic equipment. If the equipment is covered by warranty, repairs will be made and parts replaced free of charge, and the equipment will be returned to you upon completion of servicing. If the equipment is not covered by warranty, regular charges of the manufacturer or of its representatives will apply. Shipping charges are to be borne by the owner. If your Pentax was purchased outside of the country where you wish to have serviced during the warranty period, regular handling and servicing fees may be charged by the manufacturer's representatives in that country. Notwithstanding this, your Pentax returned to the manufacturer will be serviced

free of charge according to this procedure and warranty policy. In any case, however, shipping charges and customs clearance fees are to be borne by the sender. To prove the date of your purchase when required, please keep the receipts or bills covering the purchase of your equipment for at least a year. Before sending your equipment for servicing, please make sure that you are sending it to the manufacturer's authorized representatives or their accredited repair shops, unless you are sending it directly to the manufacturer. Always obtain a quotation of the service charge, and only after you accept the quoted service charge, instruct the service station to proceed with the servicing.

This warranty policy does not apply to Pentax products purchased in the U.S.A., U.K., or Canada. The local warranty policies available from Pentax distributors in those countries supersede this warranty policy.

- ④ Film rewind shaft
- ④ Film guide rails
- ④ Eyepiece accessory slots
- ④ Viewfinder eyepiece
- ④ Viewfinder frame
- ④ Sprocket
- ④ Film take-up spool
- ④ Film advance/Rewind indicator
- ④ Back cover release pin
- ④ Back cover
- ④ Film pressure plate
- ④ Connector
- ④ Film chamber
- ④ Battery compartment cover
- ④ Tripod socket
- ④ Cordless contact terminal
- ④ Shutter blades
- ④ Film rewind button
- ④ Film transport coupler

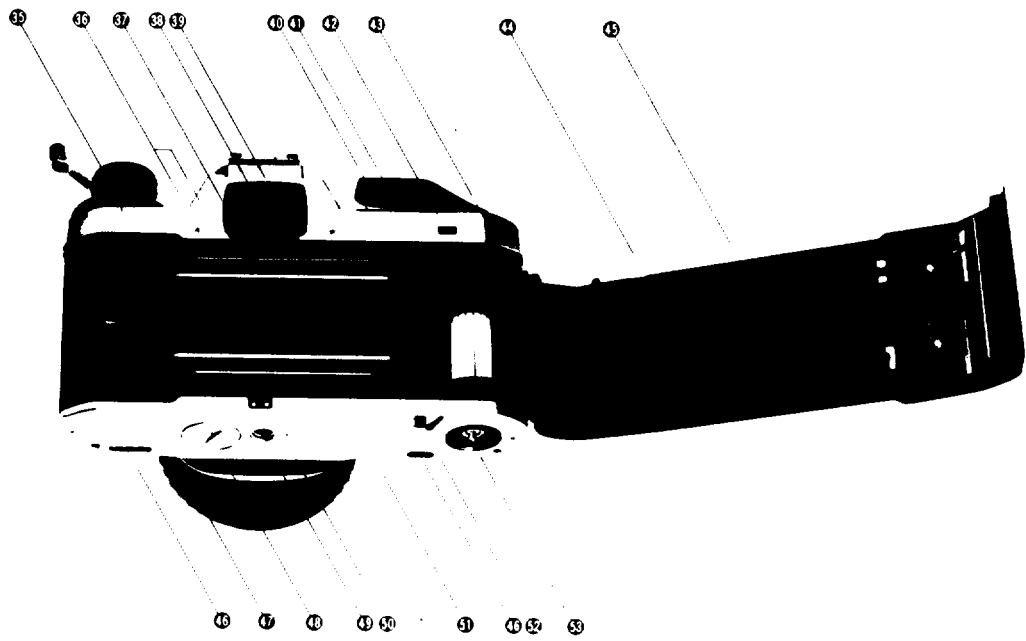





Asahi Optical Co., Ltd. C.P.O. 895, Tokyo 100-91, JAPAN
Pentax Europe n.v. Weveldlaan 3-5, 1930 Zaventem Zuid-7, BELGIUM
Pentax Handelsgesellschaft mbH Postfach 54 0169, 2000 Hamburg 54, WEST GERMANY
Pentax U.K. Limited Pentax House, South Hill Avenue, South Harrow, Middlesex HA2 0LT, U.K.
Pentax France S.A. Z.I. Argenteuil, 12, Rue Ambroise-Croizat, 95100 Argenteuil, FRANCE
Pentax (Schweiz) AG Industriestrasse 2, 8305 Dietlikon ZH, SWITZERLAND
Pentax Svenska AB Box 650, S-751 27 Uppsala, SWEDEN
Pentax Nederland Spinveld 25, 4815 HR Breda, THE NETHERLANDS
Pentax Norge A/S Stenersgt. 18, Oslo 1, NORWAY
Pentax Corporation 35 Inverness Drive East, Englewood, Colorado 80112, U.S.A.
Pentax Canada Inc. 1760 West 3rd Avenue, Vancouver, B.C. V6J 1K5, CANADA
Asahi Optical Brasileira Ind. e Com. Ltda. Rua Capitão Antonio Rosa 376, Sala 121 Ed. PBK, São Paulo, BRASIL

Specifications are subject to change without notice

56829 ENG

Copyright © Asahi Optical Co., Ltd. 1983